

1 Scope:

1.1 This specification is applicable to lead free and halogen free for zero milli-ohm resistor (Jumper) series metal alloy product only.

1.2 The product is for general purpose.

2 Explanation Of Part Numbers:

LR	1206	-	2	1	R000	J	4
Type	Size (inch)	Number of Terminals	Rated Power	Nominal Resistance	Resistance Tolerance	Packaging	
Metal Alloy Low resistance resistor	0603 0805 1206 2512	2 : 2 terminals	G =1/4 W C =1/2 W 1 = 1 W 2 = 2 W 3 = 3 W	R000 = Below 0.20 mΩ	J = ±5%	4 = 4,000pcs 5 = 5,000pcs	

3 Product Specifications:

Type	Number of Terminals	Rated Power at 70°C	Max Loading Current	Resistance (mΩ)	Operating Temperature Range
LR0603	2	$\frac{1}{4}$ W	28.9A	<0.30	-55~+150°C
LR0805	2	$\frac{1}{2}$ W	50.0 A	< 0.20	-55~+150°C
LR1206	2	$\frac{1}{2}$ W	50.0 A	< 0.20	-55~+150°C
		1 W	70.7 A	< 0.20	-55~+150°C
LR2512	2	2 W	100.0 A	< 0.20	-55~+150°C
LR2512	2	3 W	122.5 A	< 0.20	-55~+150°C

3.1 Power Derating Curve: Operating Temperature Range: - 55 ~+150 °C

For resistors operated in ambient temperatures 70°C, power rating must be derated in accordance with the curve below:

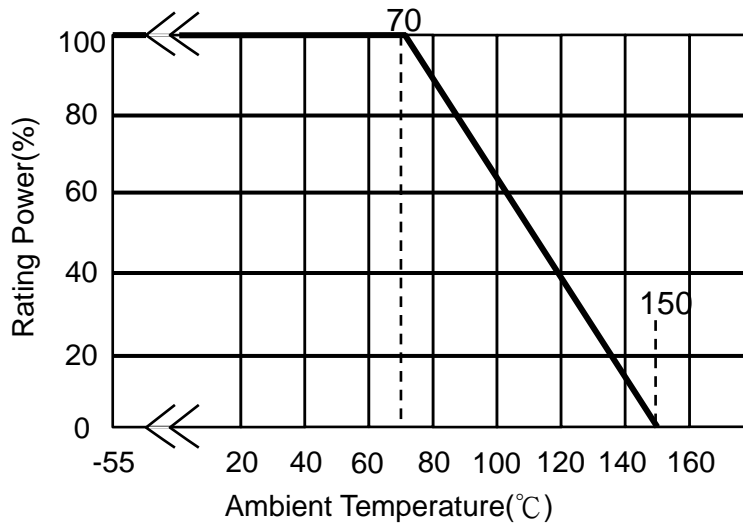

3.2 Rating Current:

The following equation may be used to determine the DC (Direct Current) or AC (Alternating Current) currents (RMS, root mean square value) of normal rated power. However, if the result value exceeds the highest current of regulated standards, the highest normal rated power is to be used.

$$I = \sqrt{P/R}$$

I=Rating Current(A)
P= Rating Power(W)
R=Resistance(Ω)

4 Physical Dimensions:

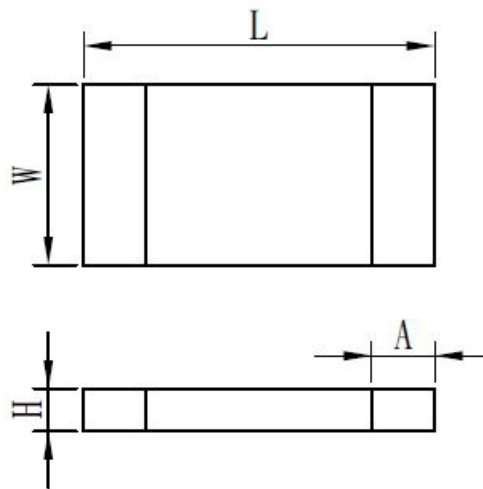

TYPE	Rated Power	Resistance Range(mΩ)	Dimensions(mm)			
			L	W	H	A
LR0603	$\frac{1}{4}$ W	<0.3	1.60±0.1	0.80±0.1	0.35±0.15	0.30±0.15
LR0805	$\frac{1}{2}$ W	<0.2	2.03±0.2	1.27±0.2	0.35±0.15	0.40±0.15
LR1206	$\frac{1}{2}$ W 1 W	<0.2	3.20±0.2	1.60±0.2	0.50±0.2	0.70±0.2
LR2512	2 W	<0.2	6.35±0.2	3.05±0.2	0.60±0.2	1.40±0.2
LR2512	3 W	<0.2	6.35±0.2	3.05±0.2	0.60±0.2	1.40±0.2

5 Reliability Performance:

5.1 Electrical Performance:

Test Item	Conditions of Test	Test Limits															
Short Time Overload	Applied Overload for 5 seconds and release the load for about 30 minutes, then measure its resistance variance rate. (Overload condition refer to below):	LR0603: $\leq 0.3 \text{ m}\Omega$ Others: $\leq 0.2 \text{ m}\Omega$															
	<table border="1"> <thead> <tr> <th>Type</th> <th>Power (W)</th> <th># of rated power</th> </tr> </thead> <tbody> <tr> <td>LR0603</td> <td>1/4</td> <td rowspan="6">4 times</td> </tr> <tr> <td>LR0805</td> <td>1/2</td> </tr> <tr> <td>LR1206</td> <td>1/2</td> </tr> <tr> <td></td> <td>1.0</td> </tr> <tr> <td>LR2512</td> <td>2.0</td> </tr> <tr> <td>LR2512</td> <td>3.0</td> </tr> </tbody> </table>	Type	Power (W)	# of rated power	LR0603	1/4	4 times	LR0805	1/2	LR1206	1/2		1.0	LR2512	2.0	LR2512	3.0
Type	Power (W)	# of rated power															
LR0603	1/4	4 times															
LR0805	1/2																
LR1206	1/2																
	1.0																
LR2512	2.0																
LR2512	3.0																
	Refer to JIS C 5201-1 4.13																
Insulation Resistance	Put the resistor in the fixture, add 100 VDC in + , - terminal for 60secs then measured the insulation resistance between electrodes and insulating enclosure or between electrodes and base material. Refer to JIS-C5201-1 4.6	$\geq 10^9 \Omega$															
Dielectric Withstanding Voltage	Applied 500VAC for 1 minute, and Limit surge current 50 mA (max.) Refer to JIS-C5201-1 4.7	No short or burned on the appearance.															

5.2 Mechanical /Constructional Performance:

Test Item	Conditions of Test	Test Limits
Resistance to Solder Heat	The tested resistor be immersed 25 mm/sec into molten solder of $260 \pm 5^\circ\text{C}$ for 10 ± 1 secs. Then the resistor is left in the room for 1 hour, and measured its resistance variance rate. Refer to JIS-C5201-1 4.18	LR0603: $\leq 0.3 \text{ m}\Omega$ Others: $\leq 0.2 \text{ m}\Omega$
		No evidence of mechanical damage
Solderability	Add flux into tested resistors, immersion into solder bath in temperature $245 \pm 5^\circ\text{C}$ for 3 ± 0.5 secs. Refer to JIS-C5201-1 4.17	Solder coverage over 95%
Vibration	The resistor shall be mounted by its terminal leads to the supporting terminals on the solid table. The entire frequency range :from 10 Hz to 55 Hz and return to 10 Hz, shall be transferred in 1 min. Amplitude : 1.5mm This motion shall be applied for a period of 4 hours in each 3 mutually perpendicular directions (a total of 12hrs) Refer to JIS-C5201-1 4.22	LR0603: $\leq 0.3 \text{ m}\Omega$ Others: $\leq 0.2 \text{ m}\Omega$
		No evidence of mechanical damage
Resistance to solvent	The tested resistor be immersed into isopropyl alcohol of $20 \sim 25^\circ\text{C}$ for 60secs, then the resistor is left in the room for 48 hrs. Refer to JIS-C5201-1 4.29	LR0603: $\leq 0.3 \text{ m}\Omega$ Others: $\leq 0.2 \text{ m}\Omega$
		No evidence of mechanical damage

5.3 Environmental Performance:

Test Item	Conditions of Test	Test Limits							
Low Temperature Exposure (Storage)	Put the tested resistor in chamber under temperature $-55\pm 2^{\circ}\text{C}$ for 1,000 hours. Then leaving the tested resistor in room temperature for 60 minutes, and measure its resistance variance rate. Refer to JIS-C5201-1 4.23.4	LR0603: $\leq 0.3 \text{ m}\Omega$ Others: $\leq 0.2 \text{ m}\Omega$							
		No evidence of mechanical damage							
High Temperature Exposure (Storage)	Put tested resistor in chamber under temperature $150\pm 5^{\circ}\text{C}$ for 1,000 hours. Then leaving the tested resistor in room temperature for 60 minutes, and measure its resistance variance rate. Refer to JIS-C5201-1 4.23.2	LR0603: $\leq 0.3 \text{ m}\Omega$ Others: $\leq 0.2 \text{ m}\Omega$							
		No evidence of mechanical damage							
Temperature Cycling (Rapid Temperature Change)	Put the tested resistor in the chamber under the temperature cycling which shown in the following table shall be repeated 1,000 times consecutively. Then leaving the tested resistor in the room temperature for 60 minutes, and measure its resistance variance rate. Refer to JIS-C5201-1 4.19	LR0603: $\leq 0.3 \text{ m}\Omega$ Others: $\leq 0.2 \text{ m}\Omega$							
		<table border="1" style="width: 100%; text-align: center;"> <thead> <tr> <th colspan="2">Testing Condition</th> </tr> </thead> <tbody> <tr> <td>Lowest Temperature</td> <td>$-55 +0/-10^{\circ}\text{C}$</td> </tr> <tr> <td>Highest Temperature</td> <td>$150 +10/-0^{\circ}\text{C}$</td> </tr> </tbody> </table>		Testing Condition		Lowest Temperature	$-55 +0/-10^{\circ}\text{C}$	Highest Temperature	$150 +10/-0^{\circ}\text{C}$
		Testing Condition							
		Lowest Temperature	$-55 +0/-10^{\circ}\text{C}$						
Highest Temperature	$150 +10/-0^{\circ}\text{C}$								
No evidence of mechanical damage									
Moisture Resistance (Climatic Sequence)	Put the tested resistor in chamber and subject to 10 cycles of damp heat and without power. Each one of which consists of the steps 1 to 7 (Figure 1). Then leaving the tested resistor in room temperature for 24 hr, and measure its resistance variance rate. Refer to MIL-STD 202 Method 106	LR0603: $\leq 0.3 \text{ m}\Omega$ Others: $\leq 0.2 \text{ m}\Omega$							
		No evidence of mechanical damage							
Bias Humidity	Put the tested resistor in chamber under $85\pm 5^{\circ}\text{C}$ and $85\pm 5\% \text{RH}$ with 10% bias and load the rated Power for 90 minutes on, 30 minutes off, total 1,000 hours. Then leaving the tested resistor in room temperature for 60 minutes, and measure its resistance variance rate. Refer to MIL-STD 202 Method 103	LR0603: $\leq 0.3 \text{ m}\Omega$ Others: $\leq 0.2 \text{ m}\Omega$							
		No evidence of mechanical damage							

5.4 Operational Life Endurance:

Test Item	Conditions of Test	Test Limits
Load Life	Put the tested resistor in chamber under temperature $70\pm 2^{\circ}\text{C}$ and load the rated voltage for 90 minutes on 30 minutes off, total 1000 hours. Then leaving the tested resistor in room temperature for 60 minutes, and measure its resistance variance rate. Refer to JIS-C5201-1 4.25	LR0603: $\leq 0.3 \text{ m}\Omega$ Others: $\leq 0.2 \text{ m}\Omega$
		No evidence of mechanical damage

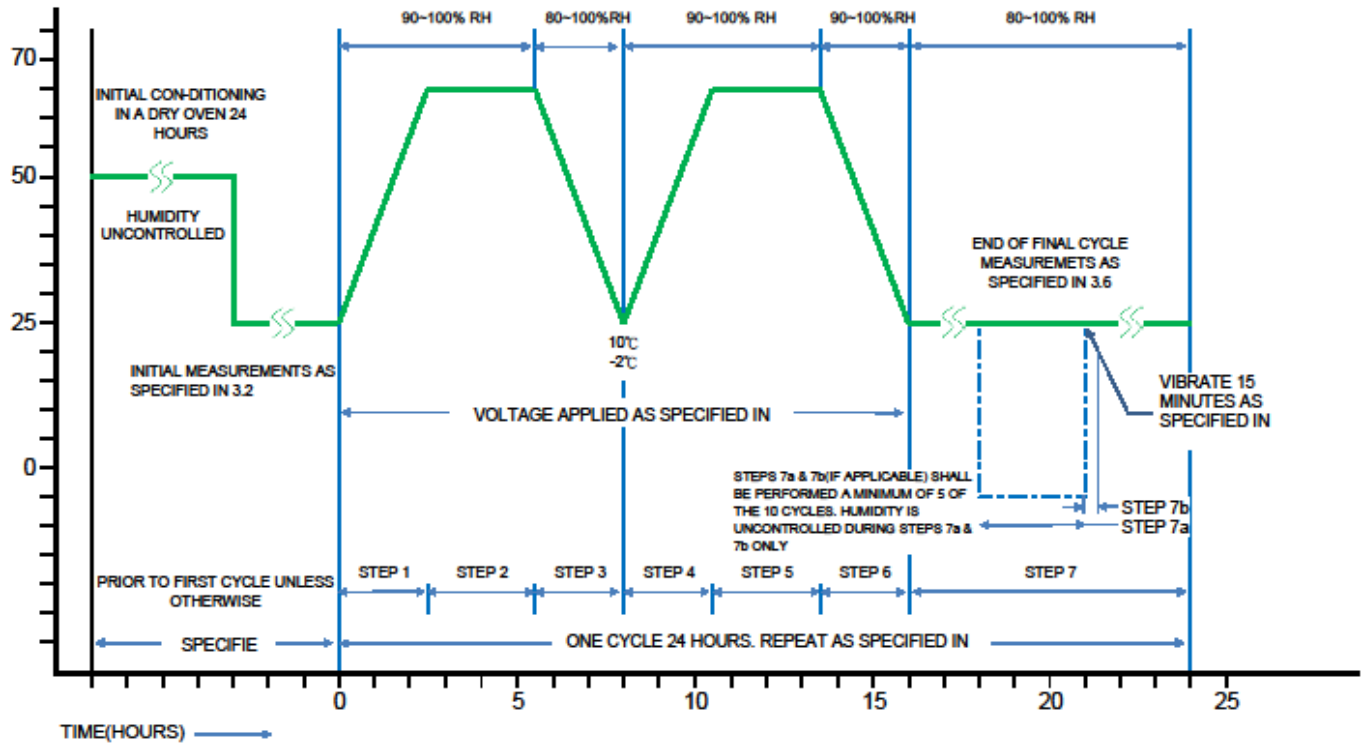

6 Marking (All the products marking are 1 digit):

6.1 LR0805 / LR0603

《EX》 Marking → ● = 0mΩ

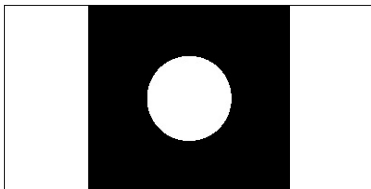

6.2 LR1206 / LR2512

《EX》 Marking → 0 = 0mΩ



7 Plating Thickness:

7.1 Ni ≥ 2μm

7.2 Sn(Tin) ≥ 3μm

7.3 Sn(Tin): Matte Sn

8 Packaging Tape Specifications:

8.1 Tape Dimensions:

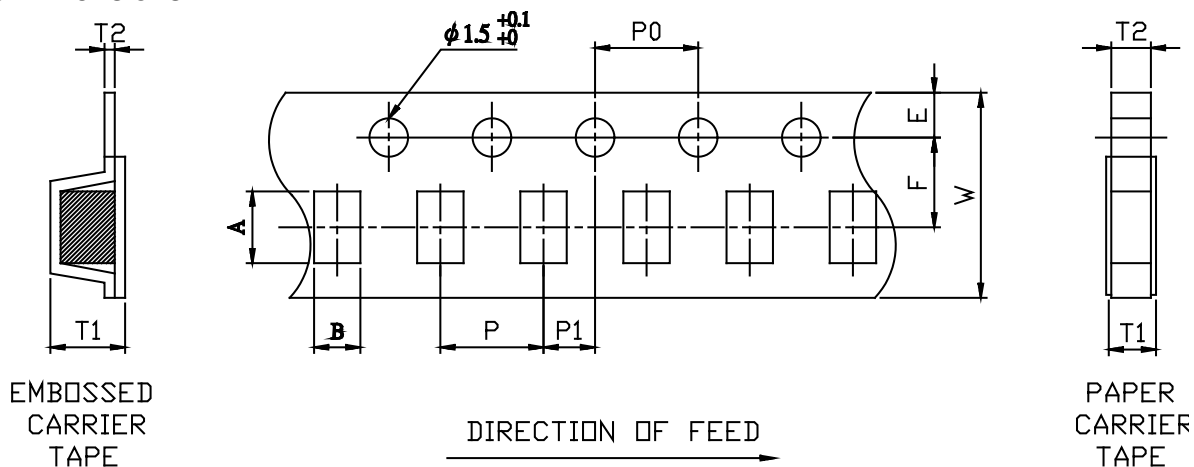

Unit: mm

DIM Item	A	B	W	E	F	T1	T2	P	P0	10*P0	P1
LR0603	1.75±0.05	1.05±0.05	8.0±0.10	1.75±0.05	3.5±0.05	0.42+0.2/-0	0.42±0.10	4.0±0.10	4.0±0.10	40.0±0.10	2.0±0.05
LR0805	2.30±0.10	1.55±0.10	8.0±0.20	1.75±0.10	3.5±0.05	0.42+0.2/-0	0.42±0.10	4.0±0.10	4.0±0.10	40.0±0.20	2.0±0.05
LR1206	3.50±0.20	1.90±0.20	8.0±0.20	1.75±0.10	3.5±0.05	0.75+0.20/-0	0.75±0.10	4.0±0.10	4.0±0.10	40.0±0.20	2.0±0.05
LR2512	6.70±0.20	3.40±0.20	12.0±0.20	1.75±0.10	5.5±0.05	1.10±0.15	0.23±0.05	4.0±0.10	4.0±0.10	40.0±0.20	2.0±0.10

8.2 Packaging Quantity:

Type	Tape Width	Packaging Quantity (pcs/reel)
		4 mm Pitch
LR0603	8 mm	5,000 pcs
LR0805	8 mm	5,000 pcs
LR1206	8 mm	4,000 pcs
LR2512	12 mm	4,000 pcs

8.3 Reel Dimensions:

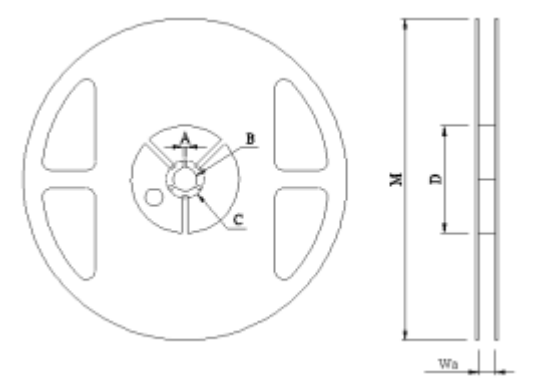

Unit: mm

Reel Type / Tape	Wa	M	A	B	C	D
7" reel for 8mm tape	12.0± 0.5	178 ± 1.0	2.0 ± 0.5	13.2 ± 0.5	17.7 ± 0.5	60.0 ± 0.5
7" reel for 12mm tape	16.2± 0.5	178 ± 1.0	2.5 ± 0.5	13.5 ± 0.5	17.7 ± 0.5	60.0 ± 0.5
7" reel for 24mm tape	24.0+2/-0	178 ± 1.0	2.0 ± 0.5	13.2 ± 0.5	17.7 ± 0.5	60.0 ± 1.0

9 Technical note (This is for recommendation, please customer perform adjustment according to actual application)

9.1 Recommend soldering method:

9.1.1 Surface-mount components are tested for solderability at a temperature of 245 °C for 3 seconds. Typical examples of soldering processes that provide reliable joints without any damage are given in below:

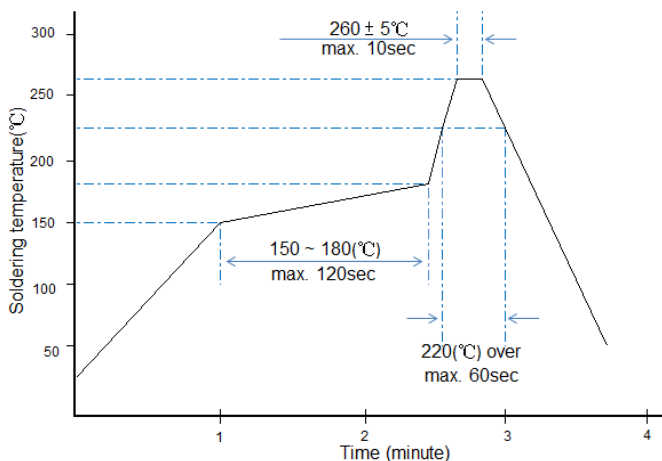

Recommended IR Reflow Soldering Profile
MEET J-STD-020D

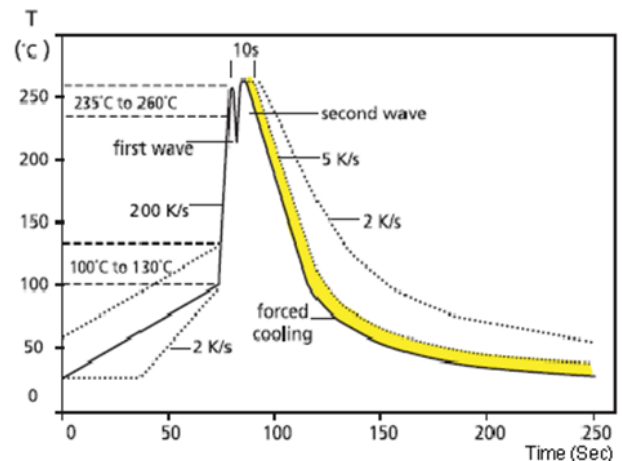

Recommended double-wave Soldering Profile
Typical values (solid line)
Process limits (dotted line)

9.2 Recommend Land Pattern:

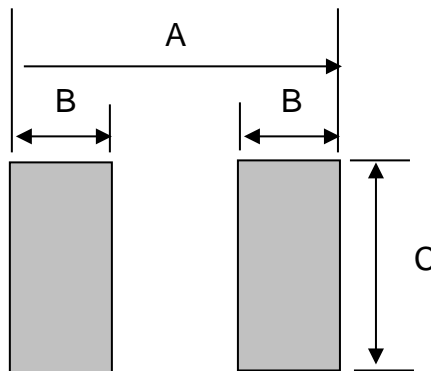

TYPE	Dimensions (mm)		
	A	B	C
LR0603	2.60	0.90	0.90
LR0805	3.40	1.30	1.30
LR1206	4.00	1.50	1.80
LR2512	7.60	2.60	3.80

9.3 Recommend dispensing method(LR2512/LR1206)

9.3.1 The structure of RALEC metal alloy resistor that both side of main body would be thinner due to process factor (as the photo below).

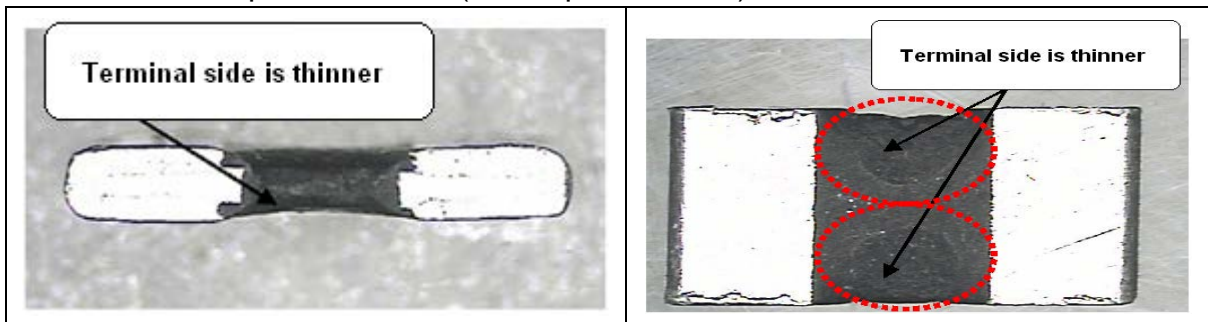

9.3.2 When customer performs wave solder process shall take note on the dispensing gap. If the gap between two dispensing is over, the red-glue will not adhesive the resistor body and be dropped out (as photo 1). Therefore, we suggest customer to narrow down the dispenser gap (as photo 2), or dispenser on the body center (as photo 3)

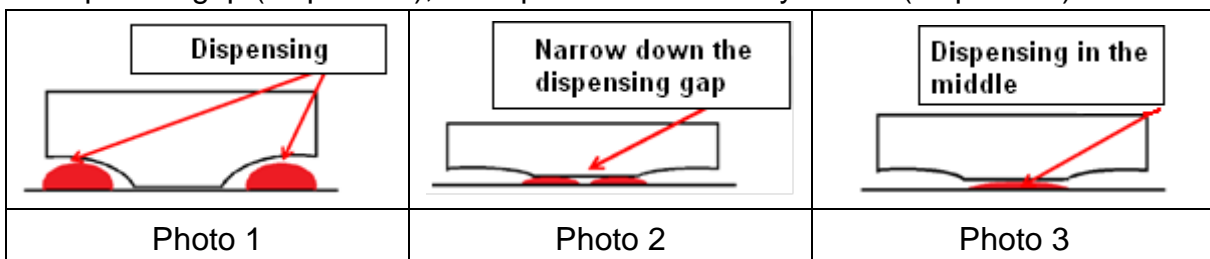

9.3.3 Product warranted solder area

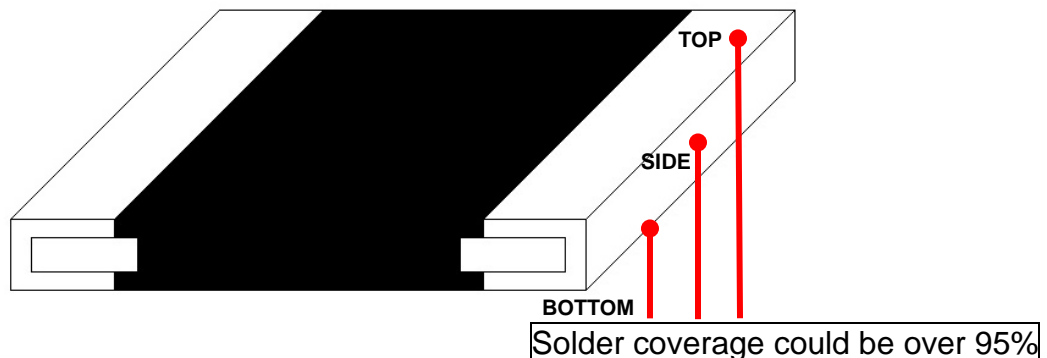

9.4 Environment Precautions:

This specification product is for general electronic use, RALEC will not be responsible for any damage, cost or loss caused by using this specification product in any special environment. If other applications need to confirm with RALEC.

If consumer intends to use our Company product in special environment or condition (including but not limited to those mentioned below), then will need to make individual recognition of product features and reliability accordingly.

- (a) Used in high temperature and humidity environment
- (b) Exposed to sea breeze or other corrosive gas, such as Cl₂、H₂S、NH₃、SO₂ and NO₂.
- (c) Used in non-verified liquids including water, oil, chemical and organic solvents.
- (d) Using non-verified resin or other coating material to seal or coat our Company product.
- (e) After soldering, it is necessary to use water-soluble detergents to clean residual solder fluxes, even though no-clean fluxes are recommended.

9.5 Momentary Overload Precautions:

The product might be out of function when momentary overloaded. Please make sure to avoid momentary overloading while using and preserving.

9.6 Operation and Processing Precautions:

- (a) Avoid damage to the edge of resistor and protective layer caused by mechanical stress.
- (b) Handle with care when printing circuit board (PCB) is divided or fixed on support body, because bending of printing circuit board (PCB) mounting will make mechanical stress for resistors.
- (c) Make sure the power rating is under the limit when using the resistor. When power rating is over the limit, the resistor will be overloaded. There might be machinery damage due to the climbing temperature.
- (d) If the resistor will be exposed under massive impact load (shock wave) in a short period of time, the working environment must be set up well before use.
- (e) Please make evaluation and confirmation when the product is well used in your company and have a through consideration of it's fail-safe design to ensure the system safety.

10 Storage and Transportation requirement:

- 10.1 The temperature condition must be controlled at $25\pm 5^{\circ}\text{C}$, the R.H. must be controlled at $60\pm 15\%$. The stock can maintain quality level in two years ◦
- 10.2 Please avoid the mentioned harsh environment below when storing to ensure product performance and its' weldability. Places exposed to sea breeze or other corrosive gas, such as Cl_2 、 H_2S 、 NH_3 、 SO_2 and NO_2 .
- 10.3 When the product is moved and stored, please ensure the correct orientation of the box. Do not drop or squeeze the box. Otherwise, the electrode or the body of the product may be damaged.

11 Attachments:

- 11.1 Document Revise Record (QA-QR-027)

Legal disclaimer

RALEC, its distributors and agents (collectively, "RALEC"), hereby disclaims any and all liabilities for any errors, inaccuracies or incompleteness contained in any product related information, including but not limited to product specifications, datasheets, pictures and/or graphics. RALEC may make changes, modifications and/or improvements to product related information at any time and without notice.

RALEC makes no representation, warranty, and/or guarantee about the fitness of its products for any particular purpose or the continuing production of any of its products. To the maximum extent permitted by law, RALEC disclaims (i) any and all liability arising out of the application or use of any RALEC product, (ii) any and all liability, including without limitation special, consequential or incidental damages, and (iii) any and all implied warranties, including warranties of fitness for a particular purpose, non-infringement and merchantability.

RALEC defined this product is for general electrical use , not design for any application for automotive electrical ,life-saving or life support equipment, or any application which may inflict casualties if RALEC product failure occurred. When consumer is using or selling products of RALEC without having discussion with the sales representatives and specifically stated the applicability mentioned above in a written form, then the client need to take a full responsibility and agree to protect RALEC from punishment and damage.

Information provided here is intended to indicate product specifications only. RALEC reserves all the rights for revising this content without further notification, as long as products are unchanged. Any product change will be announced by ECN.