

## 可调精密并联稳压器

Adjustable Precision Parallel  
Voltage Regulator

# TL431X

Product Data Sheet

AOTE DCC  
RELEASE

## ◆ 概述: summary :

TL431X是一款可调精密并联稳压器,在全温度范围内如同低温度系数的齐纳二极管一样稳定; TL431X具有较低的温度系数和较低的动态阻抗使其在开关电源、充电管理、运放电路等许多应用中代替齐纳二极管。

TL431X工作最高电压为36V,输出电压可以通过外部电阻在VREF(2.5V)到36V之间灵活设置; SOT23封装。

The TL431X is an adjustable precision shunt regulator that is as stable as a low temperature coefficient diode across the entire temperature range. The TL431A has a low temperature coefficient and low dynamic impedance, making it a replacement for Zener diodes in many applications such as switching power supplies, charge management, and operational amplifier circuits.

The TL431X's maximum operating voltage is 36V, and the output voltage can be flexibly set between VREF (2.5V) and 36V through external resistors.

## ◆ 产品特征Product features

- 可编程精确输出电压范围: 2.5V至36V ; Programmable Precise Output Voltage from 2.5V to 36V
- 高基准电压精度:  $\pm 0.5\%$ ; High reference voltage accuracy  $\pm 0.5\%$
- 电容负载下高稳定性; High Stability under Capacitive Load
- 低温偏差: 典型值为7mV ; Low-temperature deviation, typical value is 7mV
- 低动态阻抗: 典型值为0.15 $\Omega$ ; Low dynamic impedance: typical value is 0.15 $\Omega$
- 负载电流范围 :1mA~100mA; Load current range 1mA~100mA
- 低输出噪声; Low Output Noise
- 工作温度范围: -40°C至125°C; Operating temperature range -40 to 125°C

## ◆ 应用领域 Applications

- 充电器 Charger
- 电源适配器 Power adapter
- 开关电源供电 Switched-mode power supply
- 高精度电压基准 High-precision voltage reference



- ◆ 产品信息 on-product information:
- 脚位图Footage image

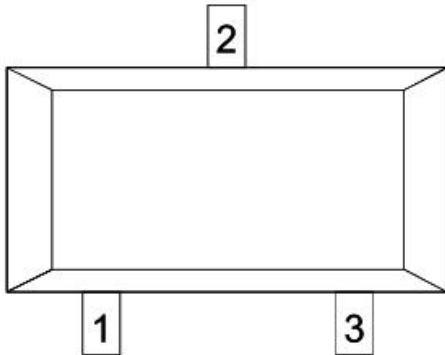

引脚编号	符号	功能
1	R	基准电压 (REF)
2	A	阳极 (ANODE)
3	K	阴极 (CATHODE)

- 脚位功能示意图Schematic diagram of foot position function

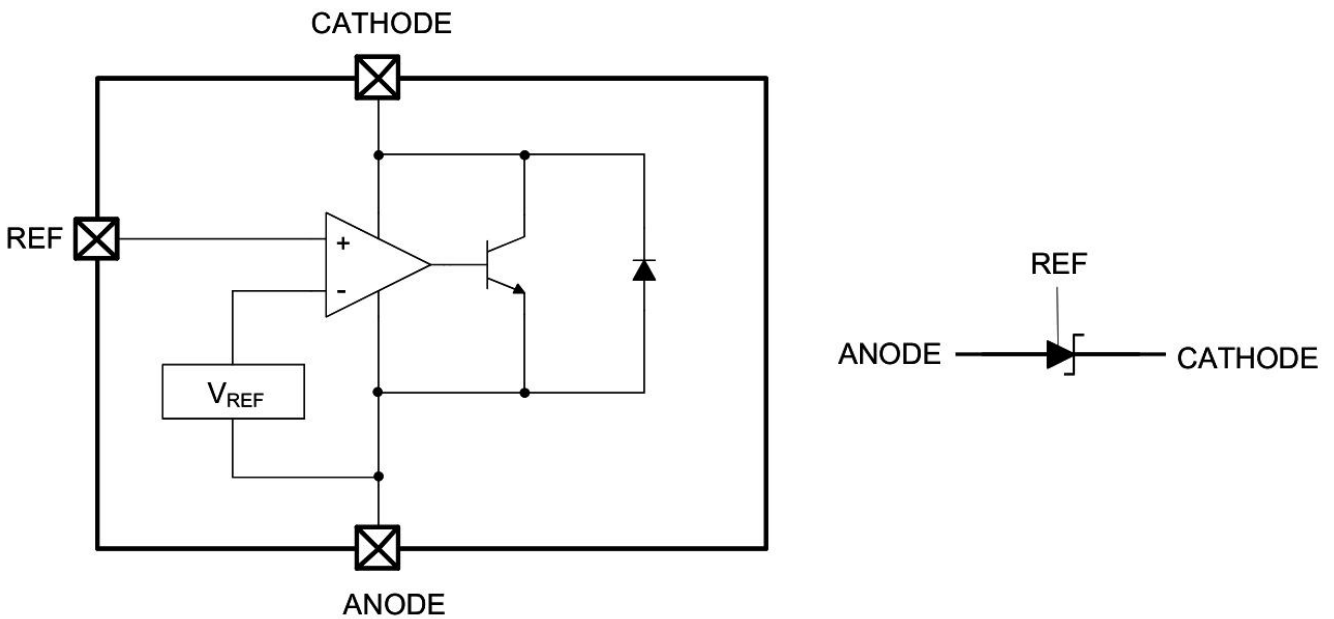

**◆ 绝对最大额定值 Absolute maximum rating**

参数 Parameter	符号 Symbol	额定值 Rating	单位 Unit
阴极电压 Cathode voltage	VKA	36	V
阴极电流范围 (连续) Cathode current range (continuous)	IKA	-80~+100	mA
基准输入电流范围 Reference input current range	IREF	10	mA
最大功率耗散 Maximum power dissipation	PD	0.4	W
结温范围 Junction Temperature Range	TJ	-40~+150	°C
储存温度范围 Storage Temperature range	TSTG	-55~+150	°C
封装热阻 (结到空气环境的热阻) Encapsulation Thermal Resistance	$\theta_{JA}$	330	°C/W

注：请在规定的最大额定值范围内使用该集成电路（IC）。超出这些限制范围运行可能导致设备性能下降或永久性损坏。 Note: Use this IC within the stated maximum ratings. Operation beyond these limits may cause degrading or permanent damage to the device.

**◆ 推荐操作条件 Recommended Operating Conditions**

参数 Parameter	符号 Symbol	最小值 Min	最大值 Max.	单位 Unit
阴极电压 Cathode Voltage	VKA	VREF	36	V
阴极电流 Cathode Current	IKA	1.0	100	mA
工作环境温度范围 Operating Ambient Temperature Range	TA	-40	125	°C

◆ **电气参数 Electrical parameters (Ta =25°C)**

参数 Parameter	符号 Symbol	条件 Condition	最小 Min	典型 Typ	最大 Max	单位 Unit	测试电路 test circuit
基准电压 Reference voltage	$\pm 0.5\%$ $V_{REF}$	$V_{KA}=V_{REF} \quad I_{KA}=10mA$	2.488	2.50	2.512	V	Fig.1
温度范围内基准电压偏差 Reference voltage deviation within the temperature range	$\Delta V_{REF}$	$V_{KA}=V_{REF}$ $I_{KA}=1mA$					
		0 ~ 70°C	-	7	10	mV	Fig.1
		-40 ~ 125°C	-	20	34		
动态阻抗 Dynamic impedance	$ Z_{KA} $	$V_{KA}=V_{REF}, I_{KA}=1\sim 100mA,$ $f\leq 1.0KHz$	-	0.15	0.5	$\Omega$	Fig.1
最小阴极电流 Minimum cathode current	$I_{KA} (MIN)$	$V_{KA}=V_{REF}$	-	0.4	1.0	mA	Fig.1
基准输入电压变化与阴极至阳极电压变化的比值 The ratio of the change in reference input voltage to the change in voltage from cathode to anode	$\Delta V_{REF}/\Delta V_{KA}$	$I_{KA}=1mA$					
		$\Delta V_{KA}=10V\sim V_{REF}$	-	-0.4	-2.7	mV/V	Fig.2
		$\Delta V_{KA}=36V\sim 10V$	-	-0.2	-2.0		
基准输入电流 Reference input current	$I_{REF}$	$I_{KA}=1mA, R1=10K\Omega, R2=\infty$		0.9	3	$\mu A$	Fig.2
在温度范围内基准输入电流偏差 Reference input current deviation within the temperature range	$\Delta I_{REF}$	$I_{KA}=1mA, R1=10K\Omega,$ $R2=\infty, T_A=-40\sim 125^\circ C$	-	0.1	2.5	$\mu A$	Fig.2
截止态阴极电流 Off-state cathode current	$I_{KA} (OFF)$	$V_{KA}=36V, V_{REF}=0$	-	0.03	1	$\mu A$	Fig.3

注:动态阻抗定义为: $|Z_{KA}|=\Delta V_{KA}/\Delta I_{KA}$

Note:The dynamic impedance is defined as: $|Z_{KA}|=\Delta V_{KA}/\Delta I_{KA}$

◆ **测试电路 Test circuit:**



图 1:  $V_{KA} = V_{REF}$



$$V_{KA} = V_{REF} \left( 1 + \frac{R1}{R2} \right) + I_{REF} R1$$

图 2:  $V_{KA} > V_{REF}$

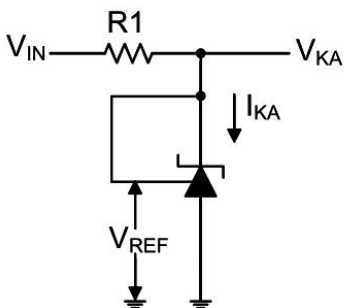
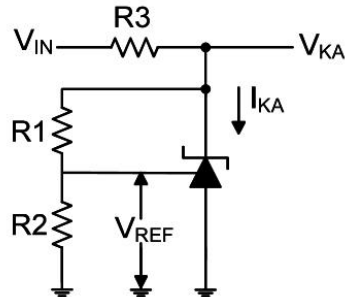

图 3:  $I_{OFF}$

◆ **典型性能特征曲线 Typical performance characteristic curve:**



◆ 小信号电压增益与频率测试曲线 (I<sub>K</sub>A=10mA, TA25°C)

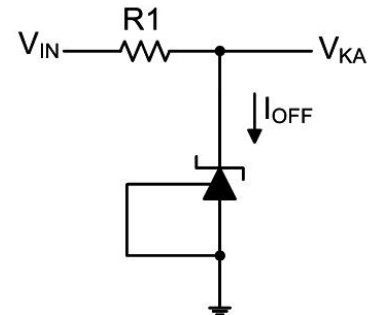
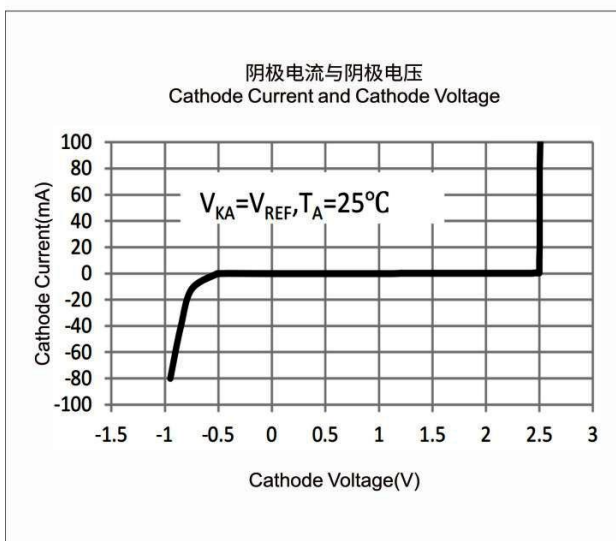
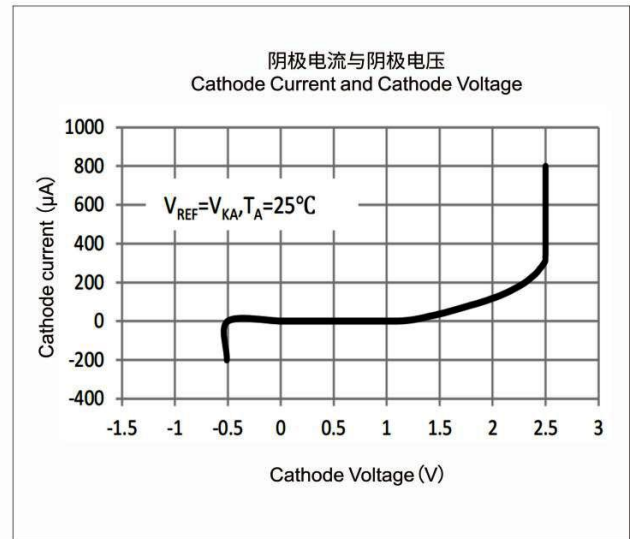
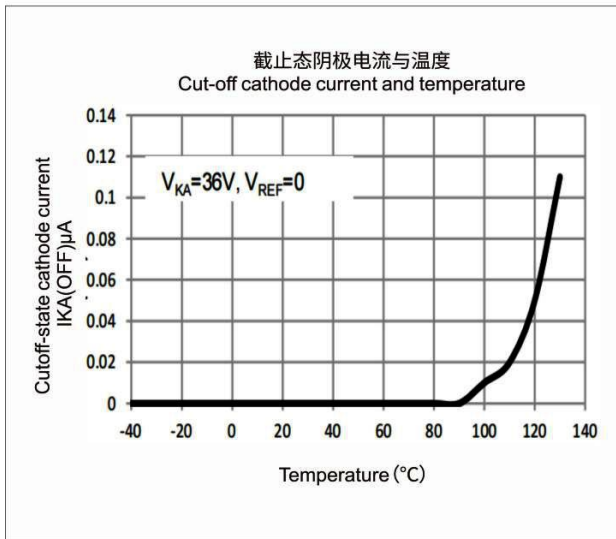
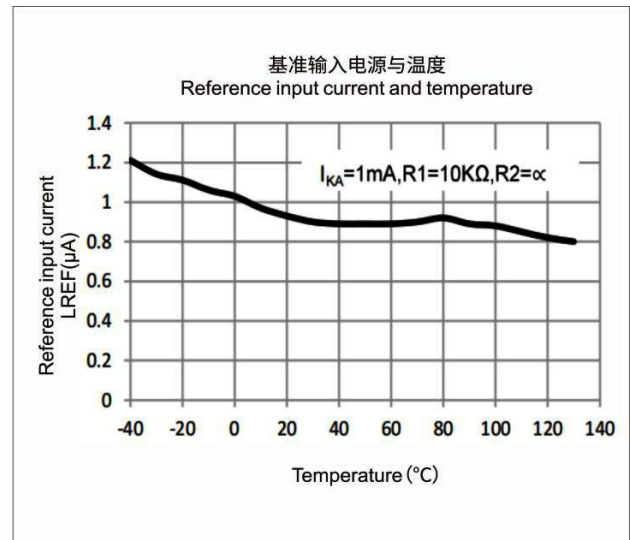
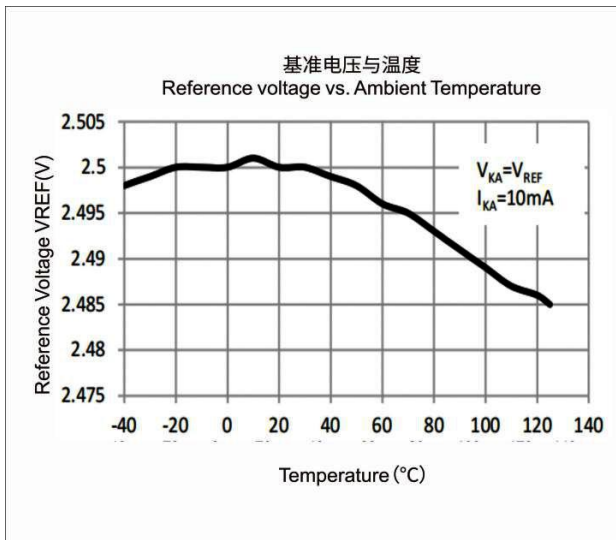
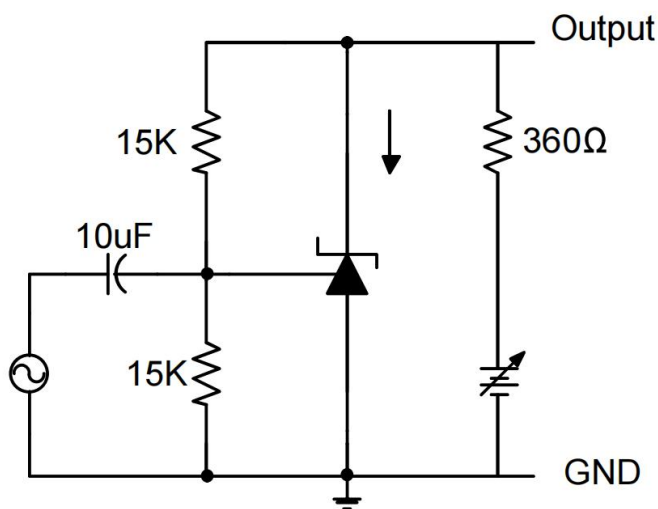
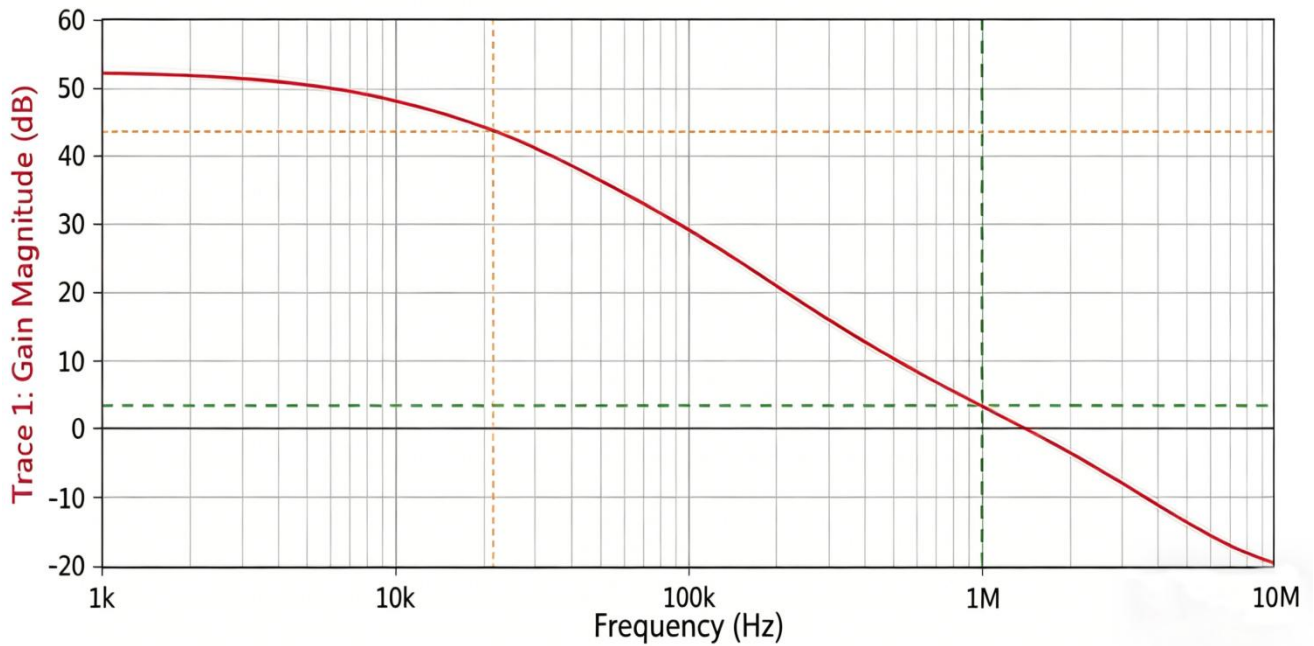

◆ 包装数量 Packaging Quantity

封装形式	最小包装数量	盒数量	箱数量
SOT-23	3000 只/盘	10 盘/盒	4盒/箱

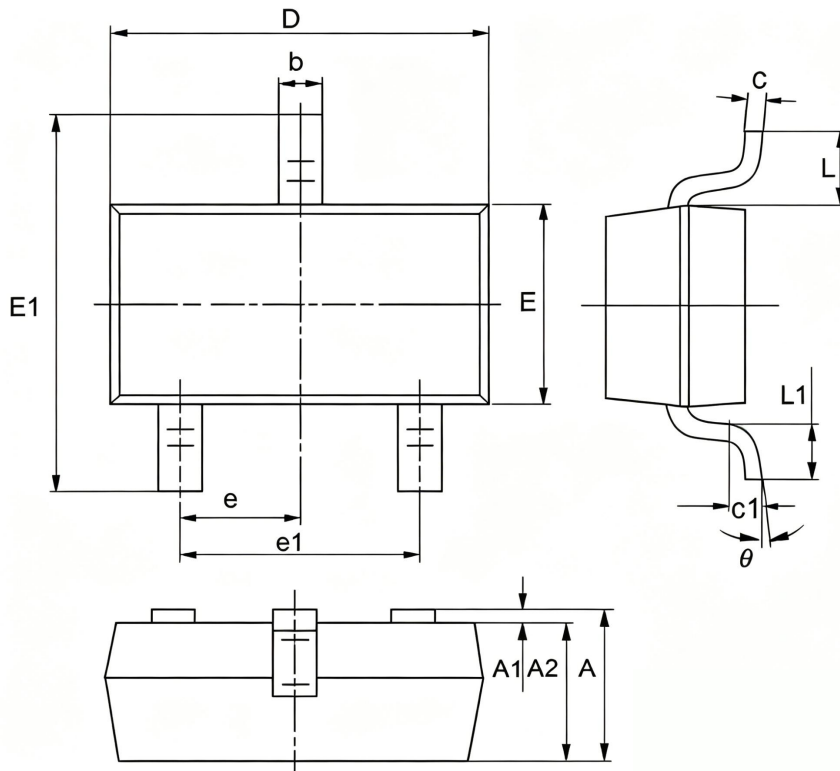
**◆ 封装尺寸及信息 Package size and information:**

参数	毫米 Millimeters		英寸 Inch	
	Min	Max	Min	Max
A	0.9	1.15	0.0354	0.0453
A1	0	0.14	0.0000	0.0055
A2	0.9	1.05	0.0354	0.0413
b	0.28	0.52	0.0110	0.0205
c	0.07	0.23	0.0028	0.0091
D	2.8	3.0	0.1102	0.1181
e1	1.8	2.0	0.0709	0.0787
E	1.2	1.4	0.0472	0.0551
E1	2.2	2.6	0.0866	0.1024
e	0.95(TYP)		0.0374(TYP)	
L	0.55(TYP)		0.0217(TYP)	
L1	0.25	0.55	0.0098	0.0217
$\theta$	0	8°	0.0000	8°
c1	0.25(TYP)		0.0098(TYP)	

### ◆ 注意 Attention

- 奥特半导体实施动态技术迭代机制，产品规格可能随工艺升级调整，最新技术参数以官网发布版本为准。  
AOTE implements dynamic technical updates. Specifications are subject to change. Refer to the official website for the latest version.
- 用户需严格遵循本规格书限定的操作条件，因超范围使用（包括但不限于过载、高温、非兼容电路设计）导致的器件失效，不在质量保证范围内。  
Users must strictly adhere to specified conditions. Failures caused by misuse (overload, high temperature, incompatible circuits) are excluded from warranty.
- 医疗设备、工业控制等关键场景应用前，需联系技术支持获取定制化验证方案。  
Contact technical support for customized validation in critical applications (medical devices, industrial control).
- 本文档有效期至2026年12月31日，后续更新将通过官网公告推送。  
This document is valid until Dec 31, 2026. Updates will be notified on the official website.
- 如需对技术参数或应用方案进行进一步确认，欢迎通过以下渠道获取官方支持：  
For further clarification on technical specifications or application solutions, please contact us through official channels: