

### GENERAL DESCRIPTION

The LW31XX Series is a group of voltage regulators with high accuracy, high speed, low drop-out, high ripple rejection and fast discharge function.

The current limiter's fold-back circuit operates as a short circuit protection as well as the output current limiter for the output pin.

Output voltage is selectable from 1.2V to 5.0V which fixed by laser trimming technologies, Step=100mV.

The LW31XX Series is available in SOT23, SOT23-3L, SOT23-5L, SOT-323, SOT-353 and DFN1x1-4L packages.

### FEATURES

- Low Quiescent Current: 40 $\mu$ A(Typ.)
- Operating Voltage Range: from 1.8V to 7.0V
- Output Voltage Range: from 1.2V to 5.0V
- Maximum Output Current: 500mA
- Output Accuracy:  $\pm 1.0\%$  @+25 $^{\circ}$ C
- Low Dropout Voltage: 590mV@500mA/3.3V
- High PSRR: 80dB@1kHz, 10mA
- Current Limiting Protection
- Output Short-Circuit Protection
- Over-Temperature Protection
- Fast Discharge Function
- Stable with 1 $\mu$ F Output Capacitor

### APPLICATIONS

- Battery-Powered Devices
- Reference Voltage Sources
- Other Low Voltage Power Suppliers

### TYPICAL APPLICATION CIRCUIT

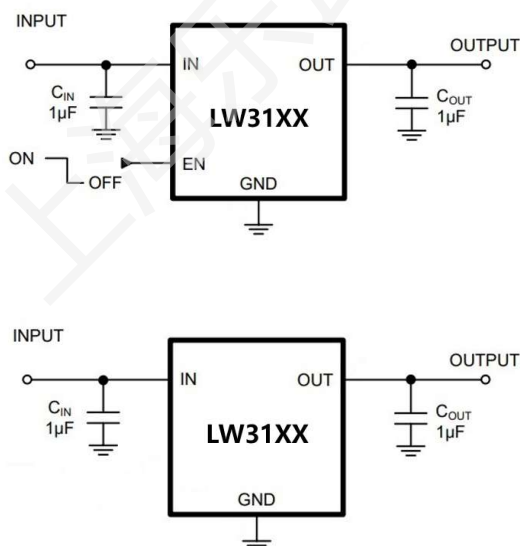

### TYPICAL PERFORMANCE CHARACTERISTICS

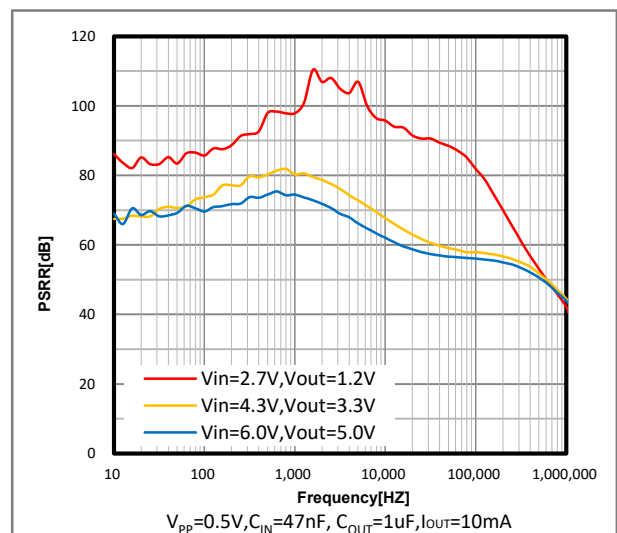

### PIN DESCRIPTION:

PIN No			SYMBOL	DESCRIPTION
SOT23/ SOT23-3L/ SOT-323	SOT23-5L /SOT-353	DFN1x1-4L		
3	1	4	VIN	Input pin. For best transient response and to minimize input impedance, use the recommended value or larger ceramic capacitor from IN to ground as listed in the Recommended Operating Conditions table and the Input and Output Capacitor Requirements section. Place the input capacitor as close to the output of the device as possible.
1	2	2	GND	Ground pin.
--	3	3	EN	Enable pin. Drive EN greater than $V_{EN(HI)}$ to turn on the regulator. Drive EN less than $V_{EN(LO)}$ to put the low-dropout regulator (LDO) into shutdown mode.
--	4	--	NC	No internal connection. Ground this pin for better thermal performance.
2	5	1	VOUT	Regulated output voltage pin. Connect a low-equivalent series resistance (ESR) capacitor to this pin. For best transient response, use the nominal recommended value or larger capacitor from OUT to GND. An internal pulldown resistor prevents a charge from remaining on OUT when the regulator is in shutdown mode ( $V_{EN} < V_{EN(LOW)}$ ).
--	--	Thermal Pad	Pad	The thermal pad is electrically connected to the GND node. Connect to the GND plane for improved thermal performance.

### PIN ASSIGNMENT

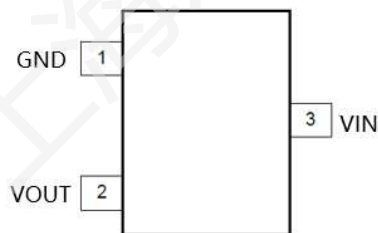

**SOT23/SOT23-3L/SOT-323**

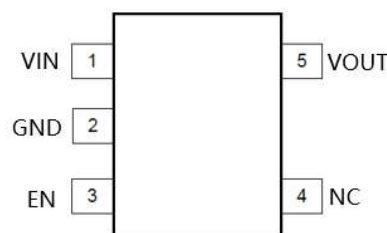

**SOT23-5L/SOT-353**

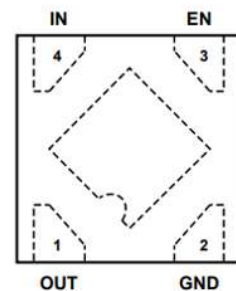

**DFN1x1-4L**

## MARK INFORMATION:

**SOT23/SOT-323/SOT-353**

31XXYY

**XX: VOLTAGE**

**YY: DATE CODE**

**SOT23-3/5L**

LW31XX  
YYYYY

**XX: VOLTAGE**

**YY: DATE CODE**

**DFN1x1-4L**

31X

**X: VOLTAGE**

1.2V	1.5V	1.8V	2.5V	2.8V	3.0V	3.3V	3.6V	4.2V	5.0V
C	D	G	H	J	L	M	P	S	T

### ABSOLUTE MAXIMUM RATINGS <sup>(1)</sup>:

(T<sub>A</sub> =25°C, unless otherwise specified.)

SYMBOL	ITEM	RATING	UNIT	
V <sub>IN</sub>	Supply Voltage	-0.3~8.0	V	
V <sub>EN</sub>	EN Pin Voltage	-0.3~8.0	V	
V <sub>OUT</sub>	V <sub>OUT</sub> pin Voltage	-0.3~ (V <sub>IN</sub> +0.3)	V	
V <sub>(ESD)</sub>	ESD Susceptibility, HBM <sup>(2)</sup>	±2000	V	
R <sub>θJA</sub>	Junction-to-ambient Thermal Resistance <sup>(3)</sup>	SOT23	425	°C/W
		SOT-323	450	
		SOT-353	445	
		SOT23-3L	400	
		SOT23-5L	390	
		DFN1x1-4L	380	
T <sub>J</sub>	Junction Temperature Range	-40~150	°C	
T <sub>STG</sub>	Storage Temperature Range	-40~150	°C	
T <sub>SOLDER</sub>	Lead Temperature (Soldering)	260°C, 10s		

#### Note:

- Stresses beyond those listed under Absolute Maximum Ratings may cause permanent damage to the device. These are stress ratings only, and functional operation of the device at these or any other conditions beyond those indicated under Recommended Operating Conditions is not implied. Exposure to absolute-maximum-rated conditions for extended periods may affect device reliability
- per ANSI/ESDA/JEDEC JS-001
- Device mounted on FR-4 PCB, Refer to JESD51-3 for detailed information on the board construction

### RECOMMENDED OPERATING RANGE:

SYMBOL	ITEM	VALUE	UNIT
V <sub>IN</sub>	V <sub>IN</sub> Supply Voltage	1.8~7.0	V
V <sub>EN</sub>	EN Pin Voltage	0~7.0	V
V <sub>OUT</sub>	V <sub>OUT</sub> Pin Voltage	1.2~5.0	V
I <sub>OUT</sub>	Output Current	0~500	mA
T <sub>J</sub>	Junction Temperature Range	-40~125	°C

### ELECTRICAL CHARACTERISTICS:

( $V_{IN}=V_{OUT(NOM)}+1V$  or  $+2V$ , whichever is greater,  $C_{IN}=C_{OUT}=1\mu F$ , unless otherwise specified, typical values are at  $T_A=25^{\circ}C$ .)

Symbol	Parameter	Test Conditions	MIN	TYP	MAX	Unit
$V_{IN}$	Input Voltage		1.8		7.0	V
$V_{OUT}$	Output Accuracy	$I_{OUT}=1mA$	-1		+1	%
$I_{LIM}$	Current Limit <sup>(1)</sup>		520	700		mA
$I_Q$	Quiescent Current	$V_{IN}=V_{EN}=V_{OUT}+1V$ , No Load		40	60	$\mu A$
$I_{SHD}$	Shutdown Current	$V_{IN}=7.0V$ , $V_{EN}=0V$			0.1	$\mu A$
$V_{DROP}$	Dropout Voltage <sup>(1)(2)</sup>	$I_{OUT}=100mA$	$V_{OUT}=3.3V$	105		mV
		$I_{OUT}=300mA$		330		
		$I_{OUT}=500mA$		590		
		$I_{OUT}=100mA$	$V_{OUT}=5.0V$	85		
		$I_{OUT}=300mA$		255		
		$I_{OUT}=500mA$		450		
$\frac{\Delta V_{OUT}}{(\Delta V_{IN} * V_{OUT(NOM)})}$	Line Regulation	$V_{IN}=V_{OUT}+1.0V$ to $7.0V$ , $I_{OUT}=1mA$		0.05	0.15	%/V
$\Delta V_{OUT}$	Load Regulation	$1mA \leq I_{OUT} \leq 500mA$		30	60	mV
$I_{SHORT}$	Short Current <sup>(1)</sup>	$V_{OUT}=0V$		100		mA
$V_{ENH}$	EN High Voltage	$V_{IN}=1.8V$ to $7.0V$ , $I_{OUT}=1mA$	1.5			V
$V_{ENL}$	EN Low Voltage				0.5	V
$T_{STR}$	Startup Time	From $V_{EN}$ 'L' $\rightarrow$ 'H' to $95% * V_{OUT}$ , $C_{OUT}=1\mu F$ , No Load		60		$\mu s$
PSRR	Power Supply Rejection Ratio	$V_{IN}=4.3V$ , $V_{OUT}=3.3V$ $V_{PP}=0.5V$ , $I_{OUT}=10mA$	$f=217Hz$	77		dB
			$f=1kHz$	80		
			$f=10kHz$	67		
$e_n$	Output Voltage Noise	$V_{IN}=4.3V$ , $V_{OUT}=3.3V$ , $f=10Hz$ to $100kHz$	$I_{OUT}=0mA$	92		$\mu V_{RMS}$
			$I_{OUT}=10mA$	102		
$T_{SD}$	Thermal Shutdown	Temperature rising		155		$^{\circ}C$
$\Delta T_{SD}$	TSD Hysteresis	Temperature falling		20		$^{\circ}C$
$R_{DSCHG}$	Output Discharge Resistance	$V_{IN}=7.0V$ , $V_{EN}=0V$		65		$\Omega$

#### NOTES:

1. Guaranteed by design
2. The dropout voltage is defined as  $V_{IN} - V_{OUT}$ , when  $V_{OUT}=95% * V_{OUT(NOM)}$

## SIMPLIFIED BLOCK DIAGRAM:

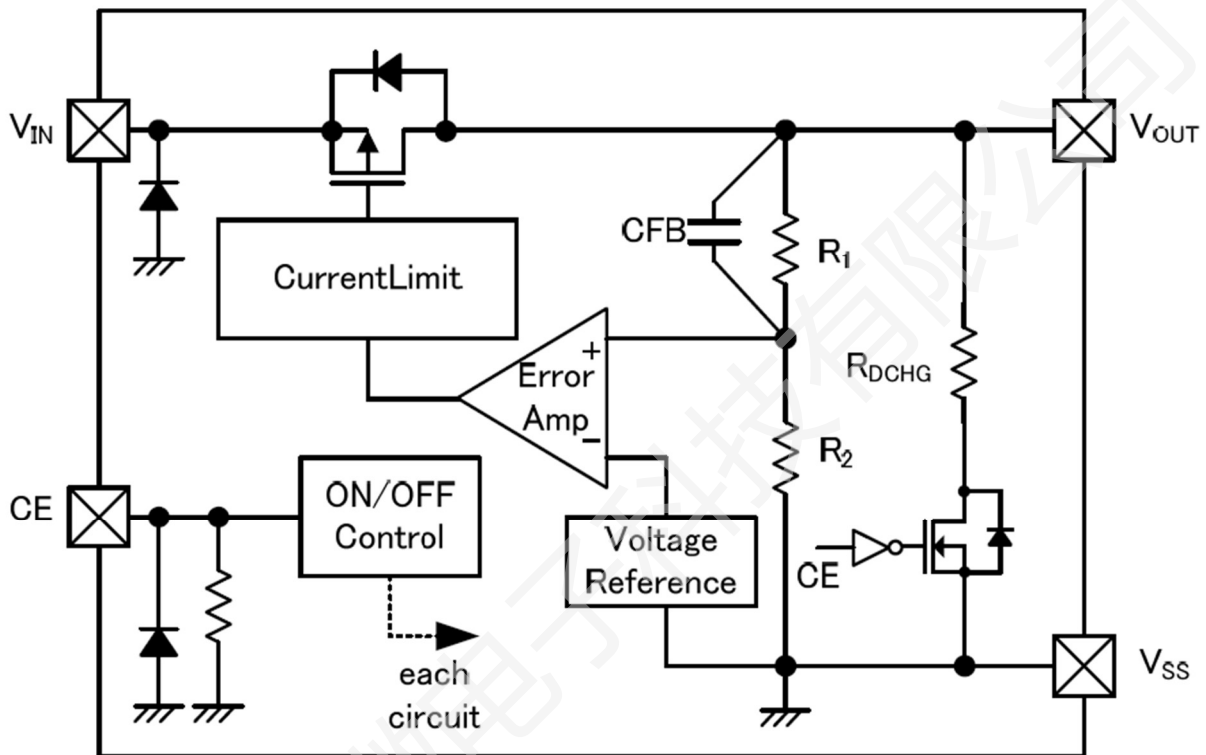

## DETAIL OPERATION DESCRIPTION:

The LW31XX Series is a low noise, high PSRR, low drop-out voltage regulator. It consists of a current limiter circuit, a driver transistor, a precision voltage reference and an error correction circuit, and is compatible with low ESR ceramic capacitors. The current limiter's fold-back circuit operates as a short circuit protection as well as the output current limiter.

### **Current Limiting and Short-Circuit Protection**

The current limit circuitry prevents damage to the MOSFET switch and the hub downstream port but can deliver load current up to the current limit threshold through the switch. When a heavy load or short circuit is applied to an enabled switch, a large transient current may flow until the current limit circuitry responds. Once this current limit threshold is exceeded the device enters constant current mode until the thermal shutdown occurs or the fault is removed.

### TYPICAL OPERATING CHARACTERISTICS:

(Tested under  $T_A = 25^\circ\text{C}$ ,  $C_{IN}=C_{OUT}=1\mu\text{F}$ , unless otherwise specified)

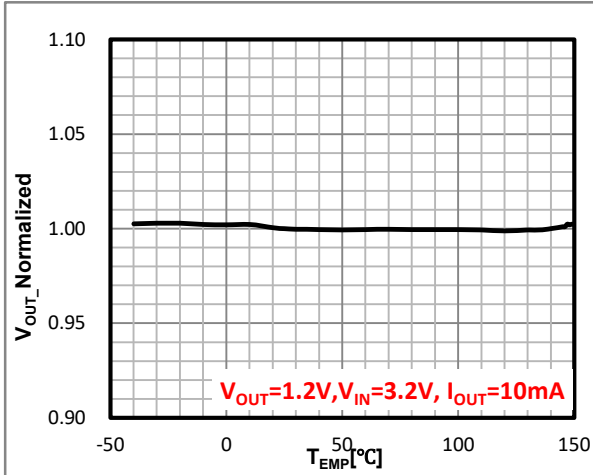

Figure 1.  $V_{OUT}$  vs Temperature

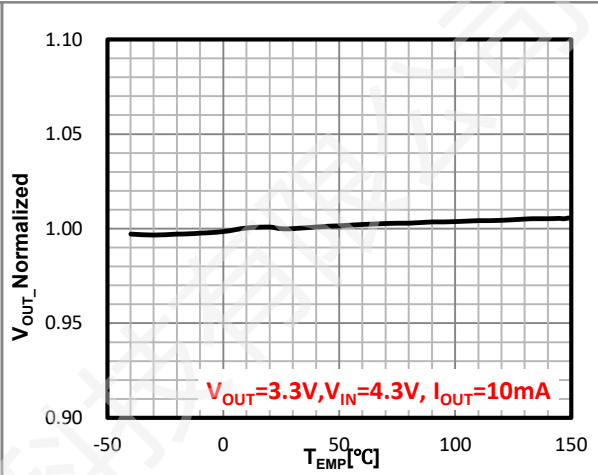

Figure 2.  $V_{OUT}$  vs Temperature

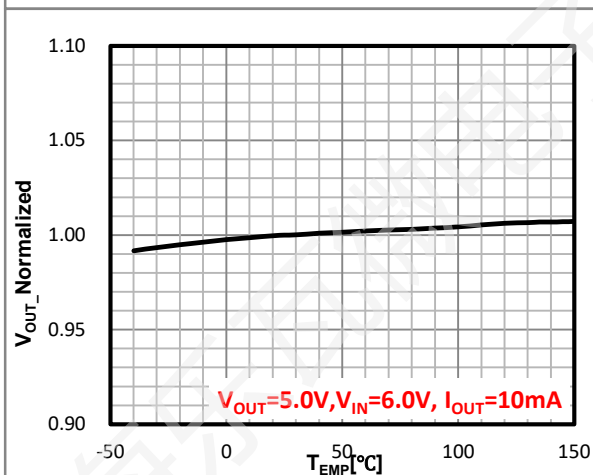

Figure 3.  $V_{OUT}$  vs Temperature

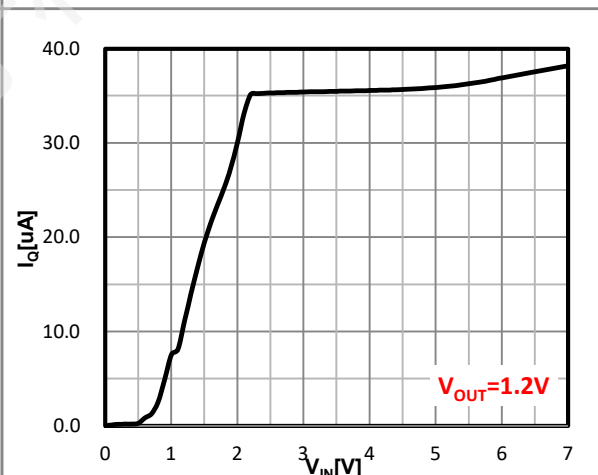

Figure 4.  $I_Q$  VS  $V_{IN}$

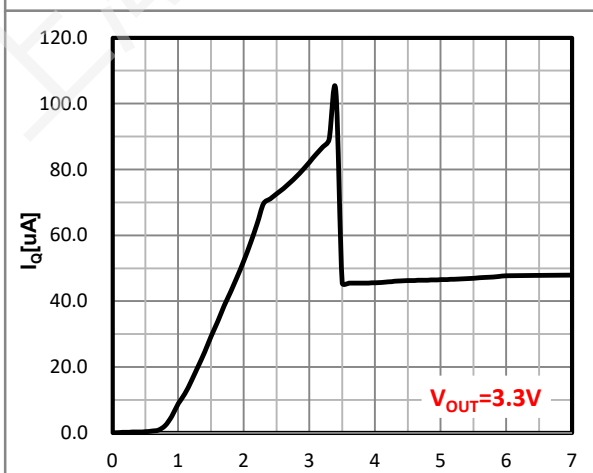

Figure 5.  $I_Q$  VS  $V_{IN}$

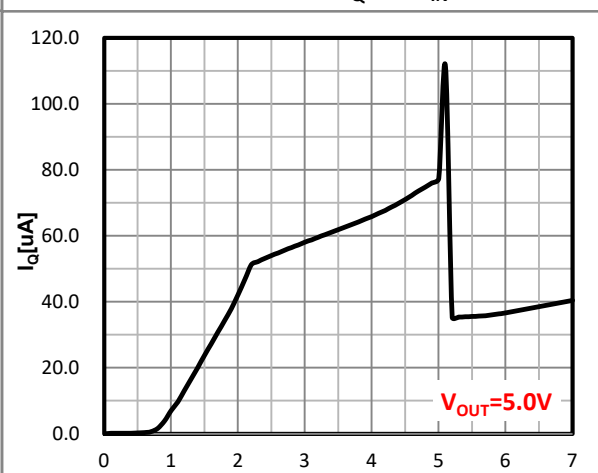
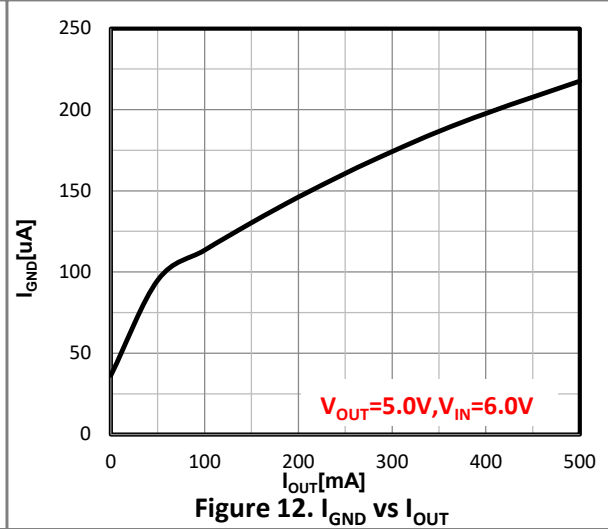
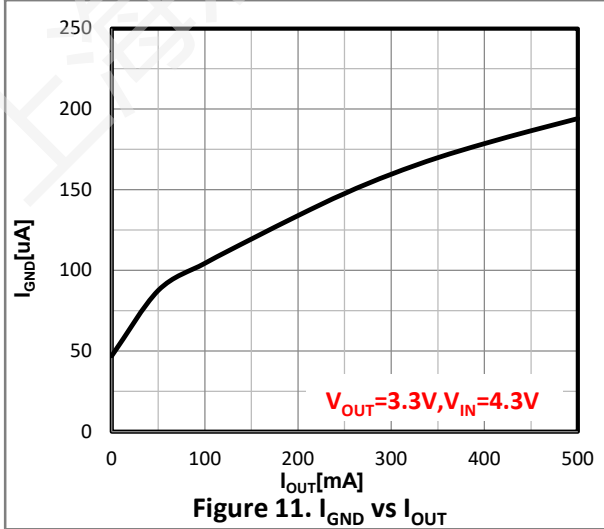
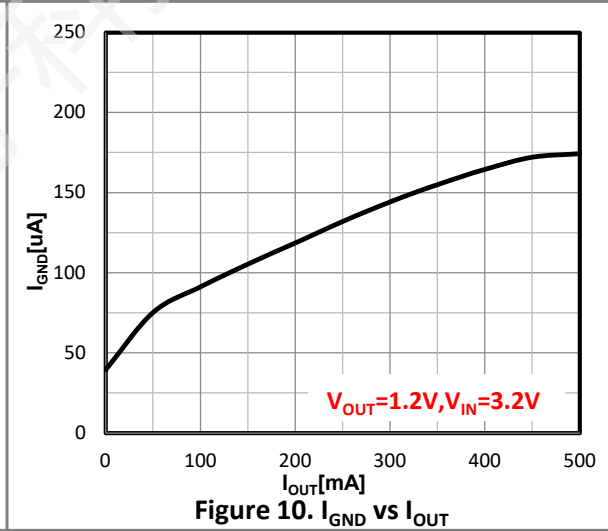
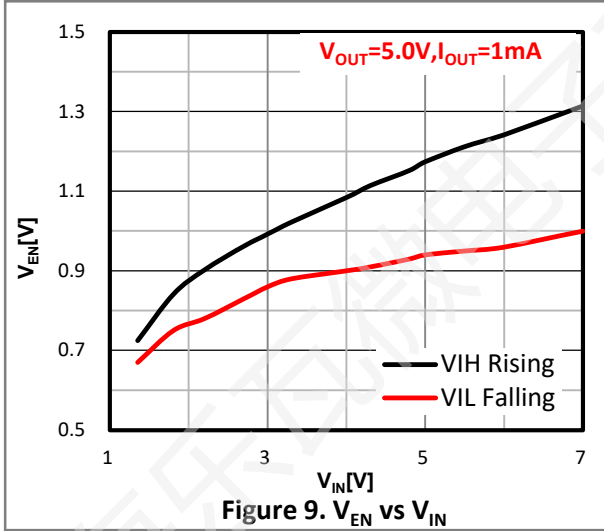
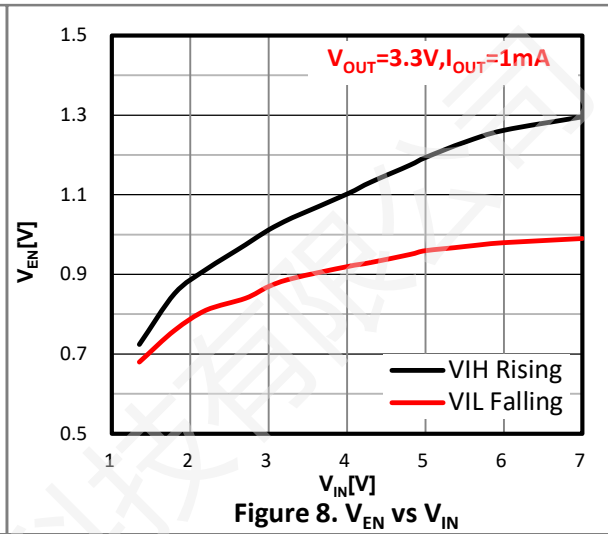
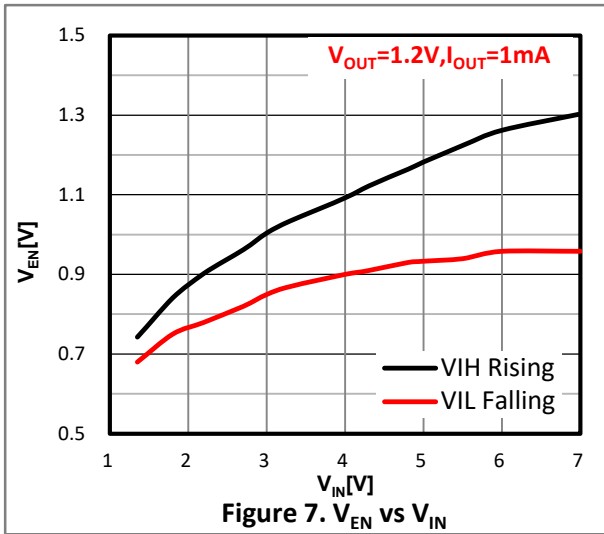

Figure 6.  $I_Q$  VS  $V_{IN}$



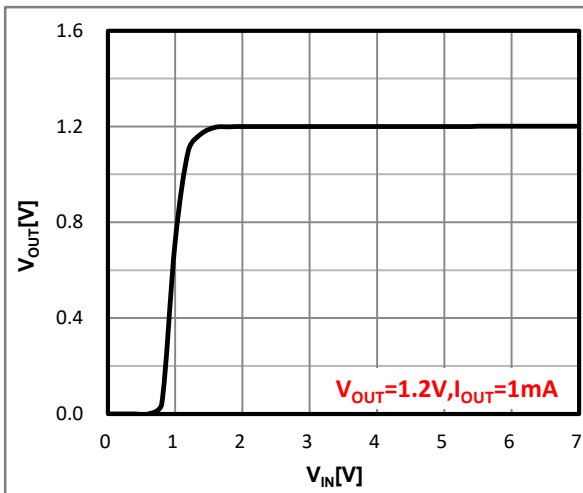

Figure 13.  $V_{OUT}$  vs  $V_{IN}$

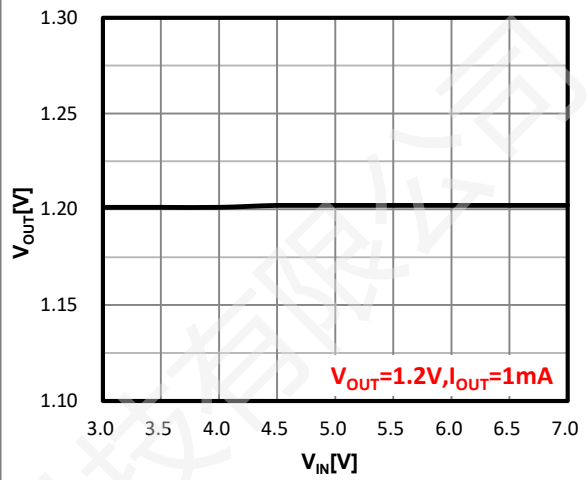

Figure 14. Line Regulation

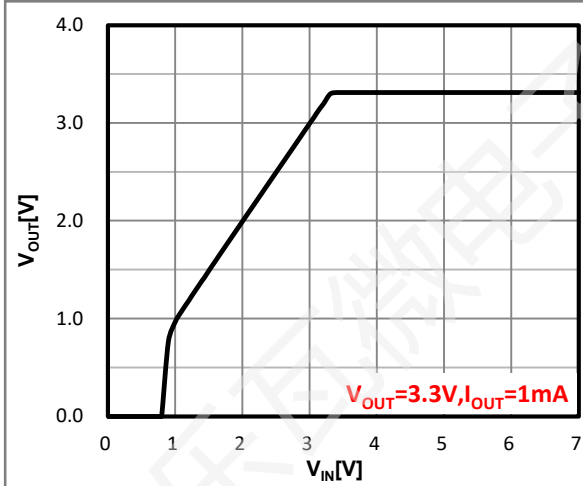

Figure 15.  $V_{OUT}$  vs  $V_{IN}$

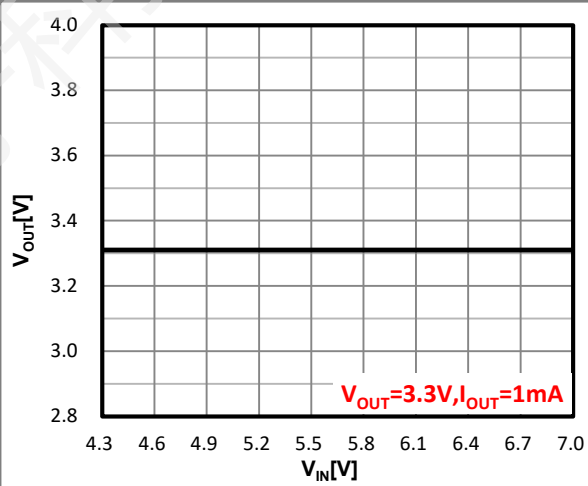

Figure 16. Line Regulation

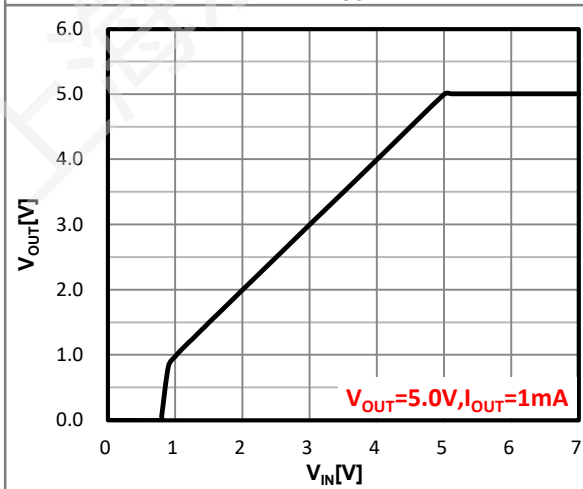

Figure 17.  $V_{OUT}$  vs  $V_{IN}$

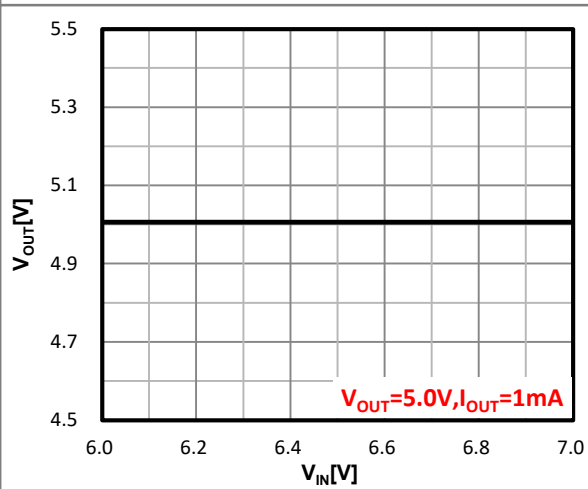

Figure 18. Line Regulation

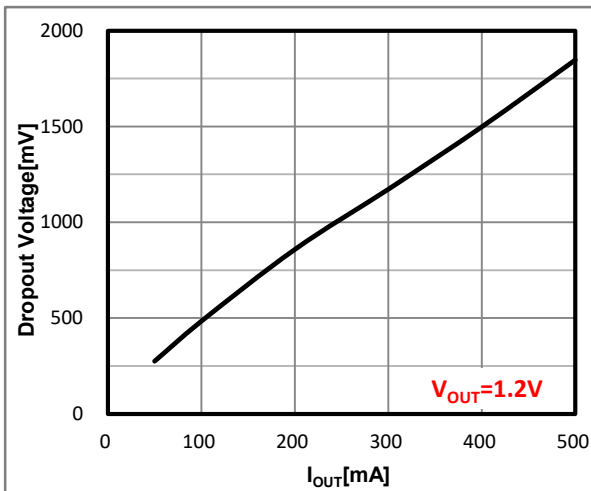

Figure 19. Dropout Voltage VS  $I_{OUT}$

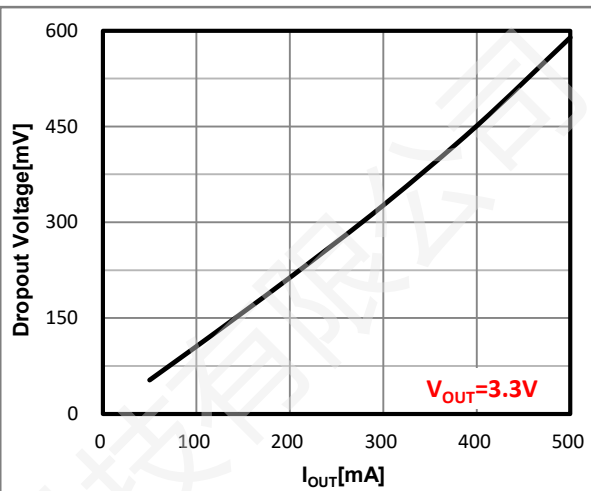

Figure 20. Dropout Voltage VS  $I_{OUT}$

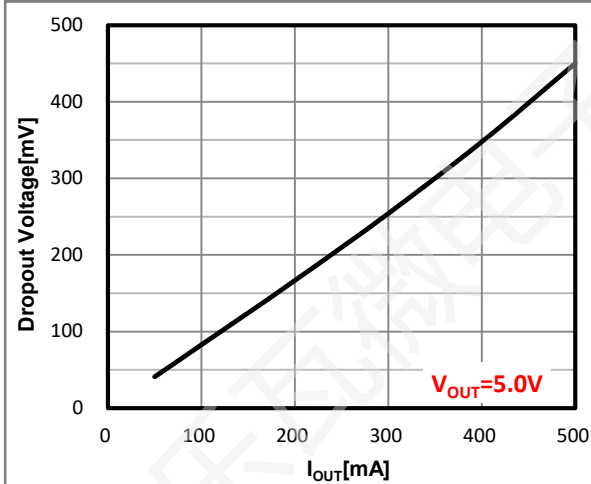

Figure 21. Dropout Voltage VS  $I_{OUT}$

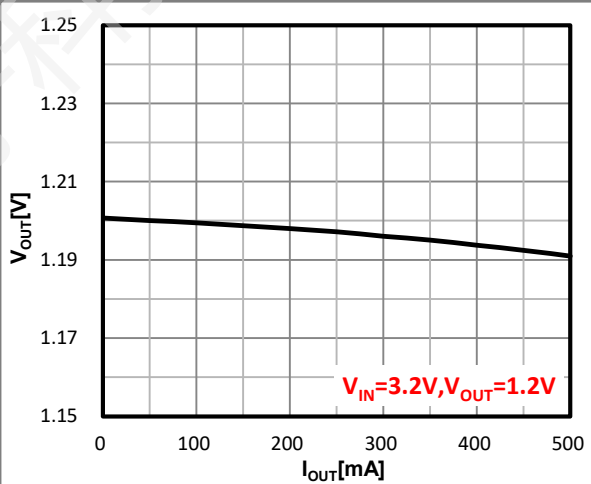

Figure 22. Load Regulation

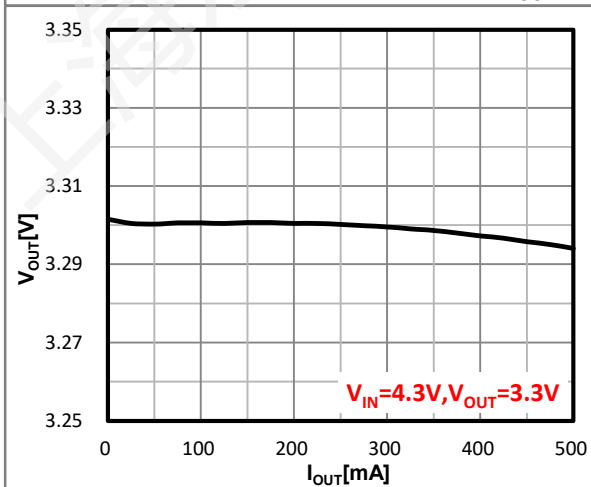

Figure 23. Load Regulation

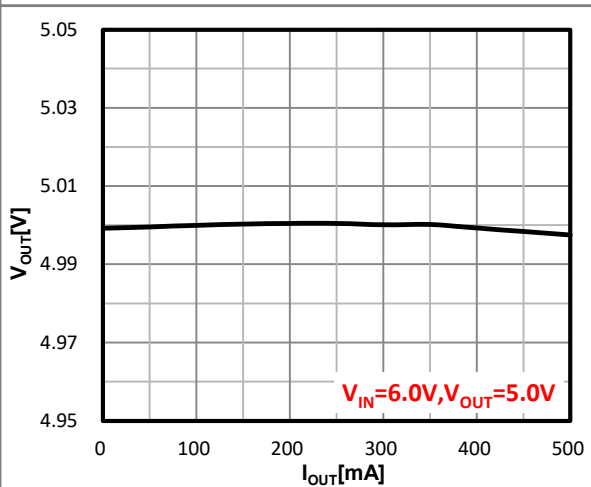
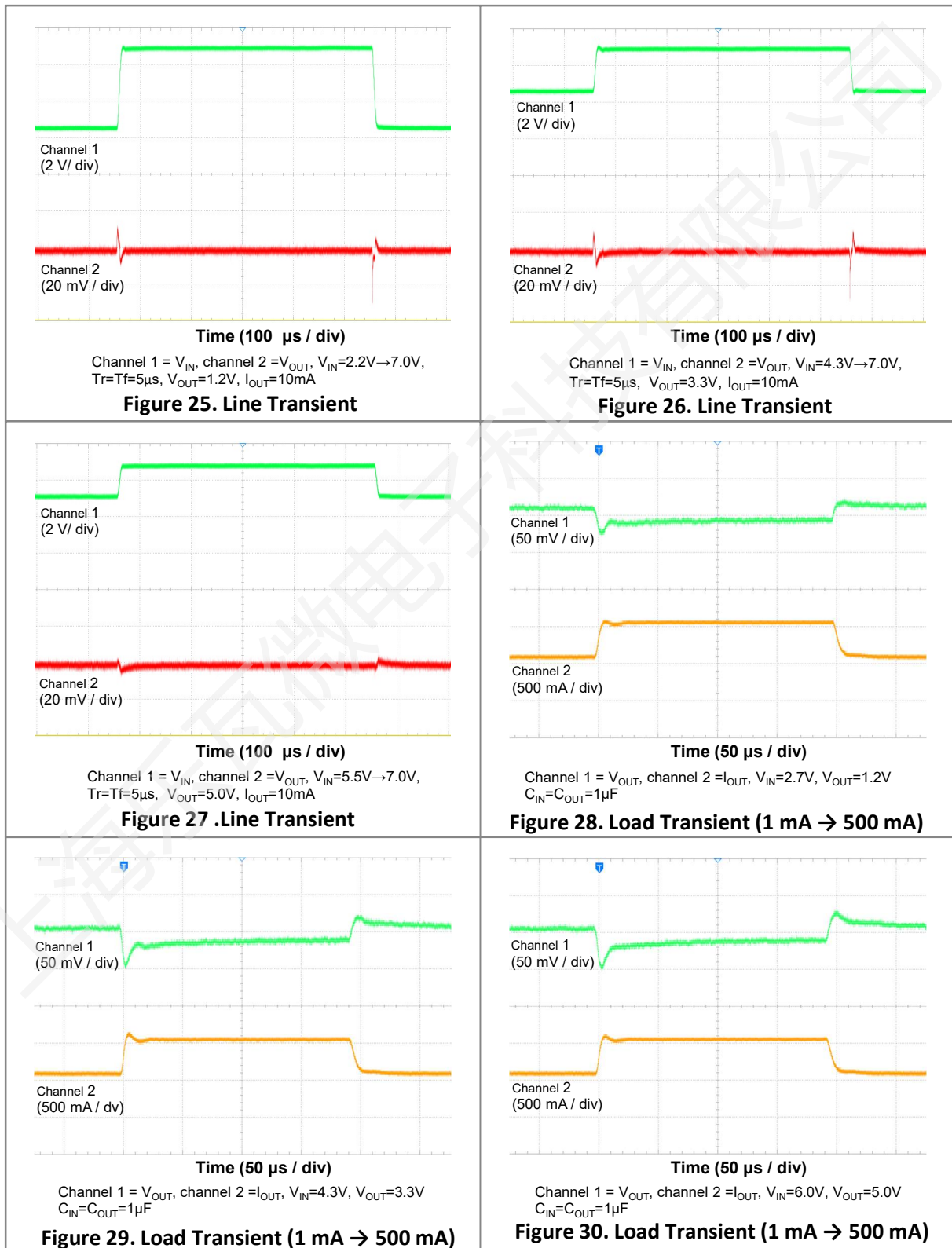
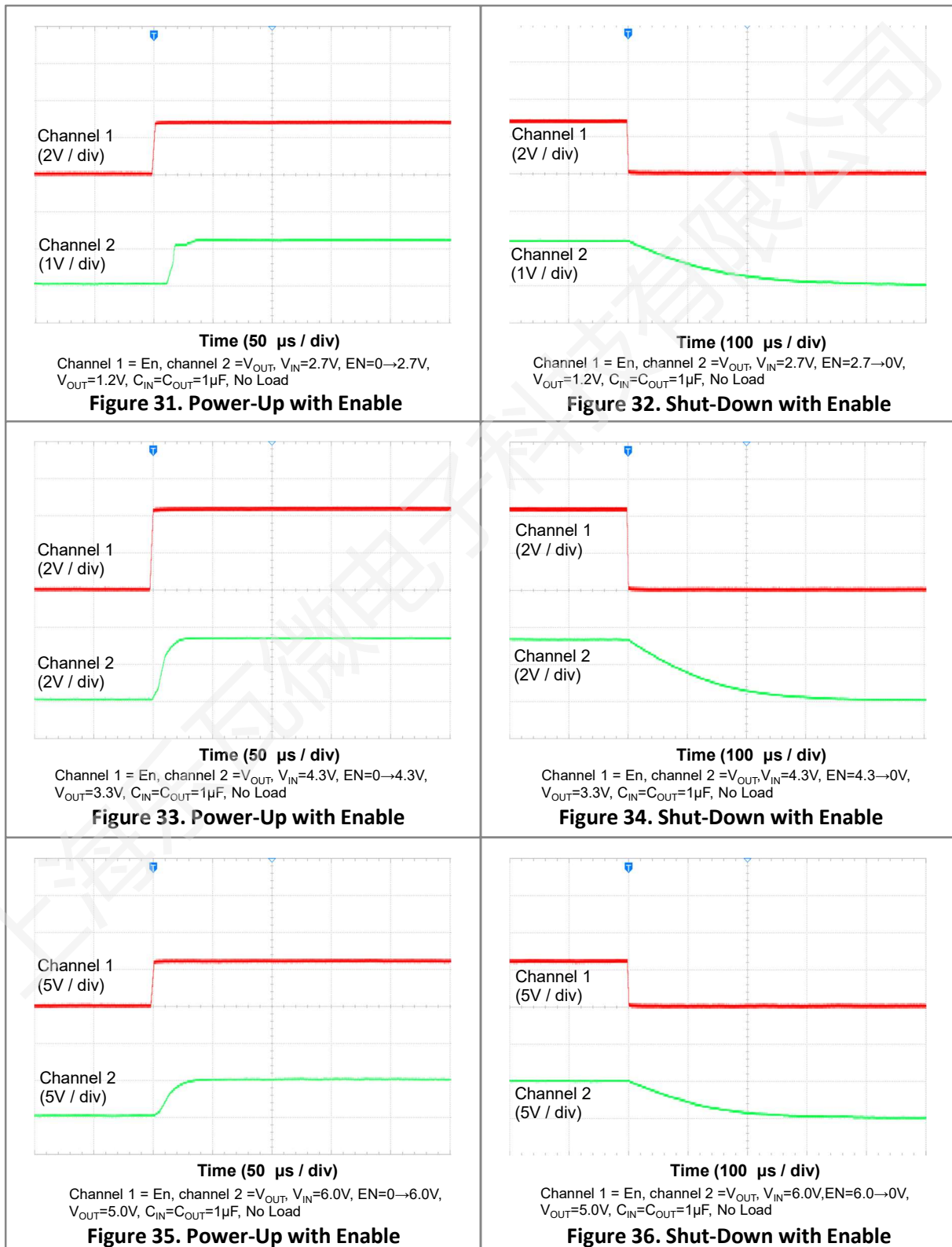
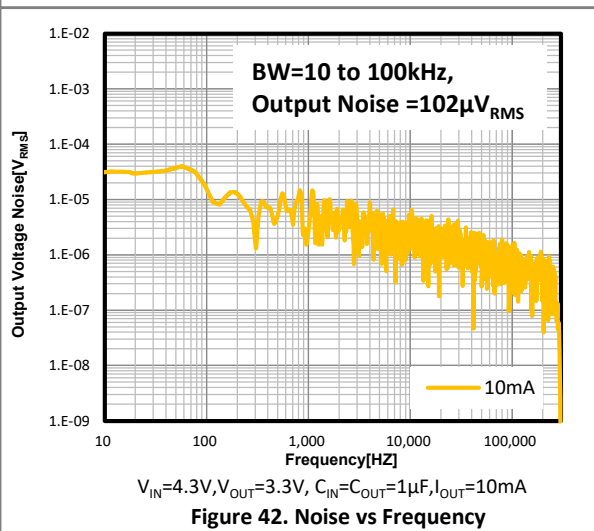
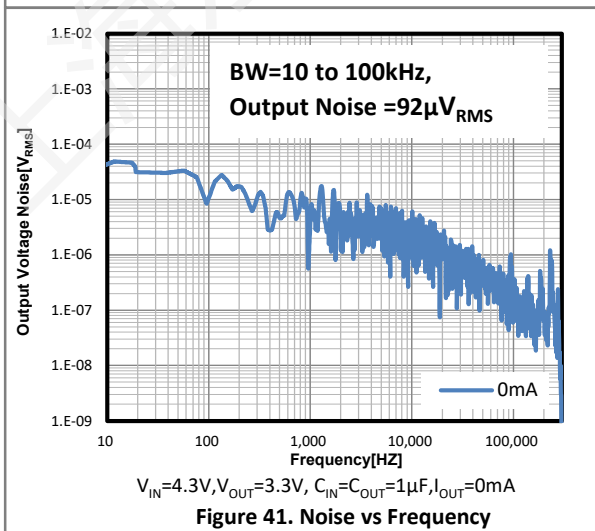
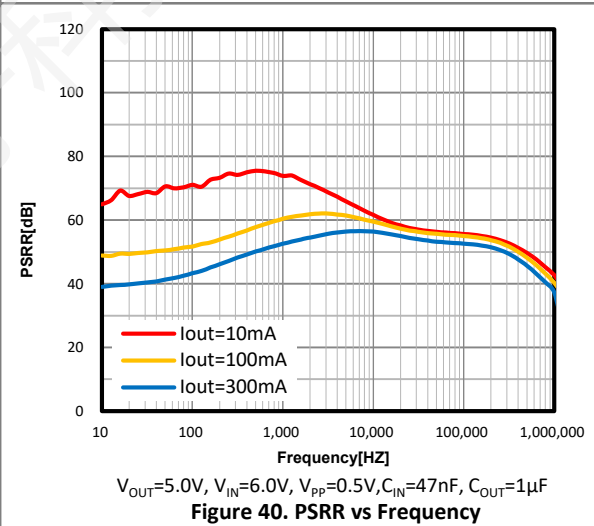
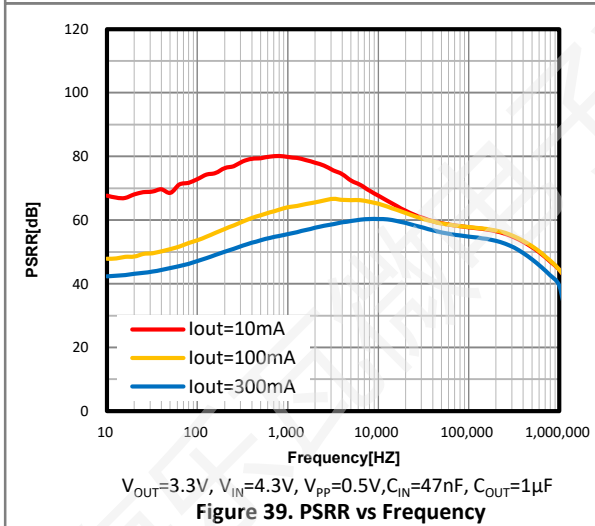
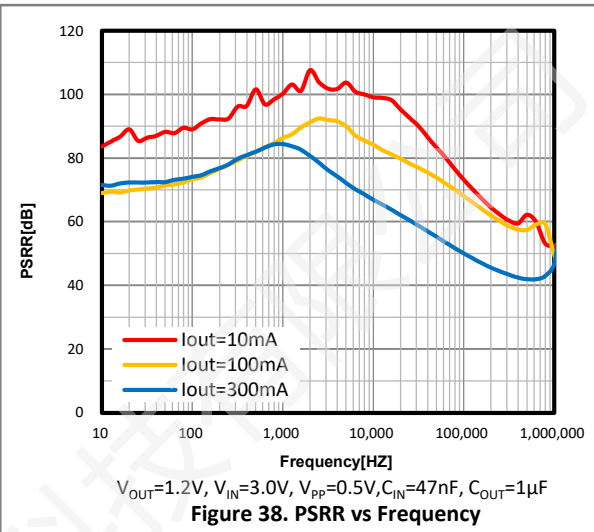
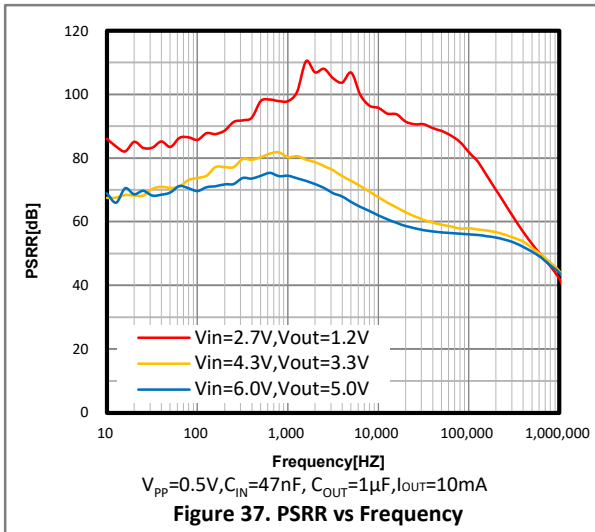

Figure 24. Load Regulation







**APPLICATION INFORMATION:**

- **Input Capacitor Selection**

Like any low-dropout regulator, the external capacitors used with the LW31XX Series must be carefully selected for regulator stability and performance. Using a capacitor whose value is  $\geq 1\mu\text{F}$  on the LW31XX Series input and the amount of capacitance can be increased without limit. The input capacitor must be located a distance less than 0.5 inch from the input pin of the IC and returned to a clean analog ground. Any good quality ceramic or tantalum can be used for this capacitor. The capacitor with larger value and lower ESR (equivalent series resistance) provides better PSRR and line-transient response.

- **Layout considerations**

To improve ac performance such as PSRR, output noise, and transient response, it is recommended that the PCB be designed with separate ground planes for VIN and VOUT, with each ground plane connected only at the GND pin of the device.

- **Output Capacitor Selection**

The output capacitor must meet both requirements for minimum amount of capacitance and ESR in all LDOs application. The LW31XX Series is designed specifically to work with low ESR ceramic output capacitor in space-saving and performance consideration. Using a ceramic capacitor whose value is at least  $1\mu\text{F}$  on the LW31XX Series output ensures stability. An appropriate output capacitor can reduce noise and improve load transient response and PSRR. The output capacitor should be located not more than 0.5 inch from the VOUT pin of the LW31XX Series and returned to a clean analog ground.

### ORDER INFORMATION:

LW31①②③④⑤⑥

Designator	Item	Symbol	Description
①②	Output Voltage	12~50	e.g.1.2V→①=1,②=2
③④⑤⑥	Packages	N23C	SOT23
		N23D	SOT23-3L
		A23E	SOT23-5L
		NW2C	SOT-323
		NW5E	SOT-353
		N11E	DFN1x1-4L

Part #	Output Voltage	Package	Shipping
LW3112N23C	1.2V	SOT23	3000 Pcs/ Tape & Reel
LW3115N23C	1.5V		
LW3118N23C	1.8V		
LW3125N23C	2.5V		
LW3128N23C	2.8V		
LW3130N23C	3.0V		
LW3133N23C	3.3V		
LW3136N23C	3.6V		
LW3142N23C	4.2V		
LW3150N23C	5.0V		
LW3112N23D	1.2V	SOT23-3L	3000 Pcs/ Tape & Reel
LW3115N23D	1.5V		
LW3118N23D	1.8V		
LW3125N23D	2.5V		
LW3128N23D	2.8V		
LW3130N23D	3.0V		
LW3133N23D	3.3V		
LW3136N23D	3.6V		
LW3142N23D	4.2V		
LW3150N23D	5.0V		

Part #	Output Voltage	Package	Shipping
LW3112A23E	1.2V	SOT23-5L	3000 Pcs / Tape & Reel
LW3115A23E	1.5V		
LW3118A23E	1.8V		
LW3125A23E	2.5V		
LW3128A23E	2.8V		
LW3130A23E	3.0V		
LW3133A23E	3.3V		
LW3136A23E	3.6V		
LW3142A23E	4.2V		
LW3150A23E	5.0V		
LW3112NW2C	1.2V	SOT-323	3000 Pcs/ Tape & Reel
LW3115NW2C	1.5V		
LW3118NW2C	1.8V		
LW3125NW2C	2.5V		
LW3128NW2C	2.8V		
LW3130NW2C	3.0V		
LW3133NW2C	3.3V		
LW3136NW2C	3.6V		
LW3142NW2C	4.2V		
LW3150NW2C	5.0V		
LW3112NW5E	1.2V	SOT-353	3000 Pcs/ Tape & Reel
LW3115NW5E	1.5V		
LW3118NW5E	1.8V		
LW3125NW5E	2.5V		
LW3128NW5E	2.8V		
LW3130NW5E	3.0V		
LW3133NW5E	3.3V		
LW3136NW5E	3.6V		
LW3142NW5E	4.2V		
LW3150NW5E	5.0V		

Part #	Output Voltage	Package	Shipping
LW3112N11E	1.2V	DFN1x1-4L	10000 Pcs/ Tape & Reel
LW31135N11E	1.35V		
LW3115N11E	1.5V		
LW3118N11E	1.8V		
LW3125N11E	2.5V		
LW3128N11E	2.8V		
LW3130N11E	3.0V		
LW3133N11E	3.3V		
LW3136N11E	3.6V		
LW3142N11E	4.2V		
LW3150N11E	5.0V		

If customers have special output voltage requirements, please contact us.

## PACKAGE OUTLINE:

### SOT23 Package

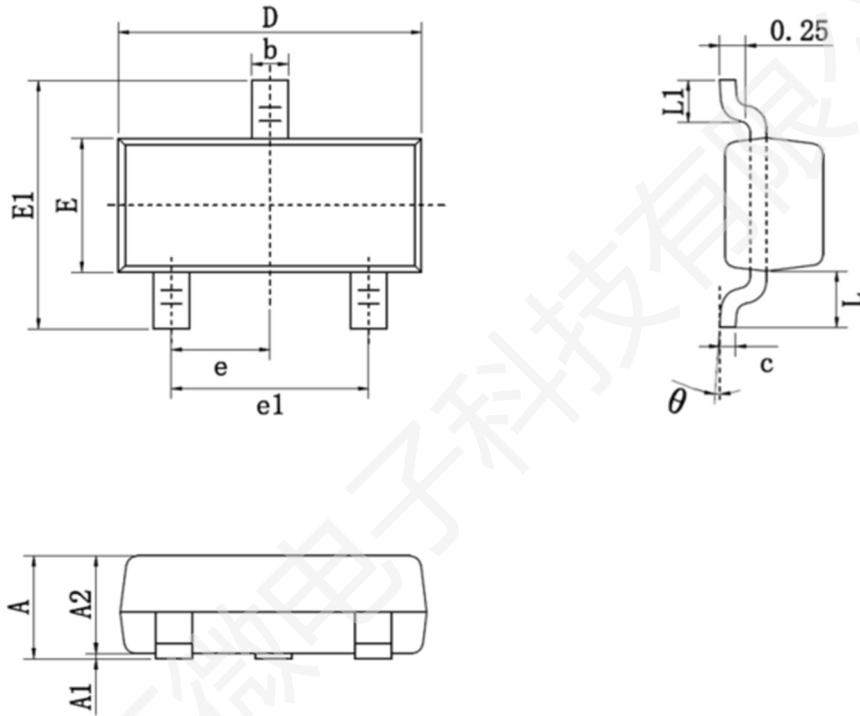

COMMON IN DIMENSION (MM)

Symbol	Min.	Nom.	Max.
A	—	—	1.150
A1	0.000	—	0.100
A2	0.900	0.950	1.050
b	0.300	0.400	0.500
c	0.100	0.150	0.200
D	2.800	2.900	3.000
E	1.200	1.300	1.400
E1	2.250	2.400	2.550
e	0.950 TYP		
e1	1.800	1.900	2.000
L	0.550 REF		
L1	0.290	—	0.500

## SOT23-3L Package

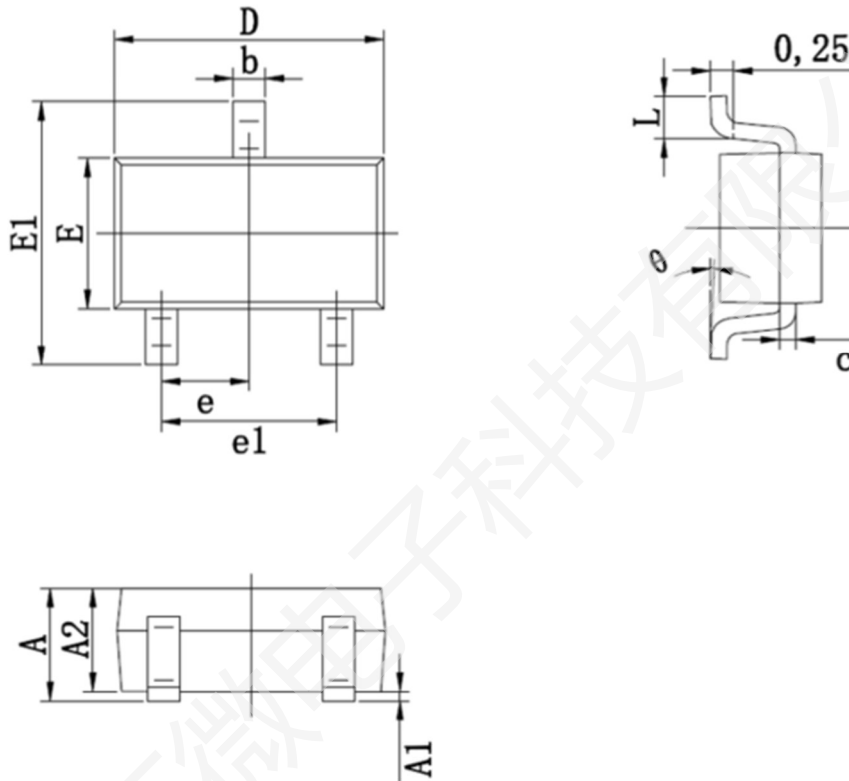

COMMON DIMENSION (MM)			
PKG	SOT23-3L		
Symbol	MIN	NOM	MAX
A	—	—	1.300
A1	0.010	—	0.150
A2	1.050	1.100	1.150
b	0.300	0.350	0.400
c	0.125	0.150	0.175
D	2.870	2.920	2.980
E	1.550	1.610	1.670
E1	2.650	2.850	3.000
e	0.95 BSC		
e1	1.800	1.900	2.000
L	0.300	0.450	0.600
$\theta$	0°	4°	8°

## SOT23-5L Package

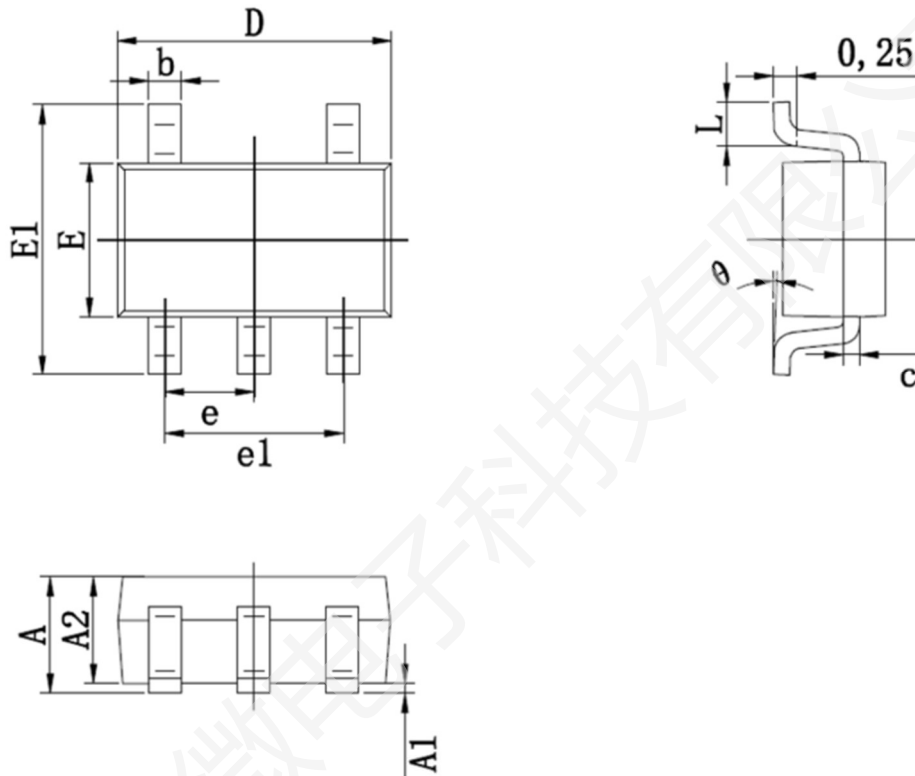

COMMON DIMENSION (MM)			
PKG	SOT23-5L		
Symbol	MIN	NOM	MAX
A	—	—	1.300
A1	0.010	—	0.150
A2	1.050	1.100	1.150
b	0.300	0.350	0.400
c	0.125	0.150	0.175
D	2.870	2.920	2.980
E	1.550	1.610	1.670
E1	2.650	2.850	3.000
e	0.95 BSC		
e1	1.800	1.900	2.000
L	0.300	0.450	0.600
θ	0°	4°	8°

## SOT-323 Package

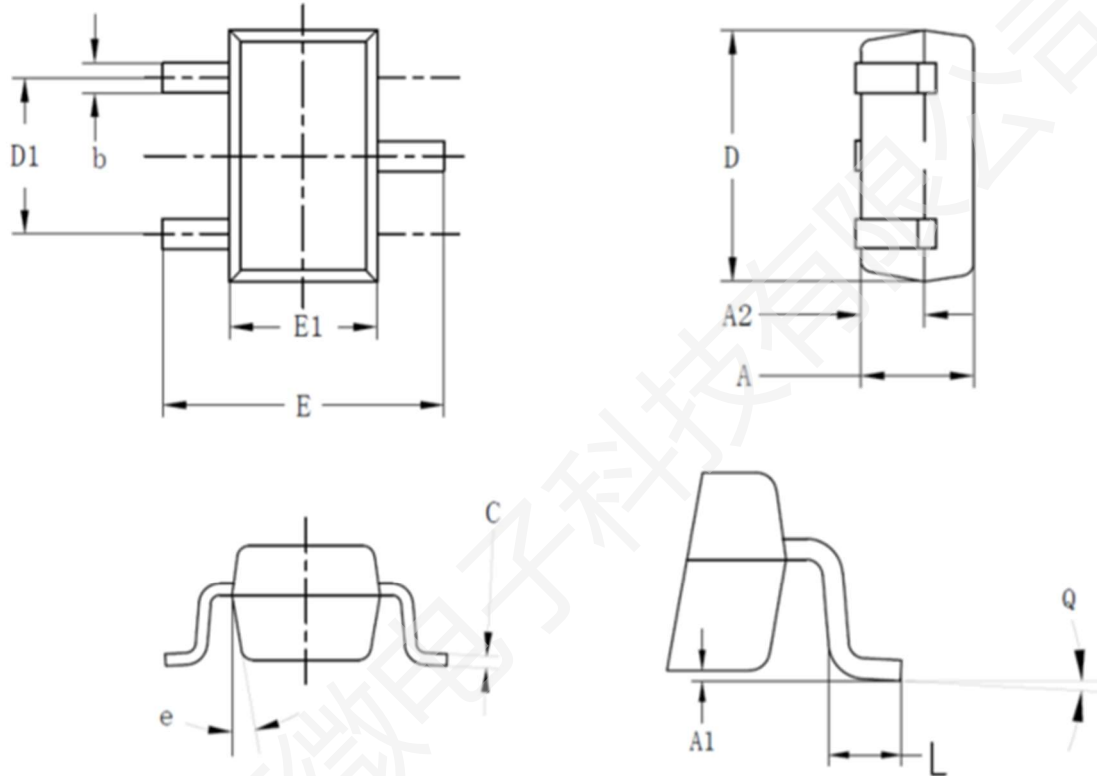

COMMON IN DIMENSION (MM)			
PKG	SOT-323		
Symbol	Min	Nom	Max
A	0.910	0.960	1.010
A1	0.010	0.060	0.150
A2	0.500	0.540	0.600
b	0.200	0.250	0.310
C	0.100	0.110	0.120
D	2.050	2.100	2.250
D1	1.250	1.300	1.350
E	2.300	2.400	2.500
E1	1.200	1.260	1.350
L	0.260	0.360	0.460
e	10°		
Q	0°	4°	8°

## SOT-353 Package

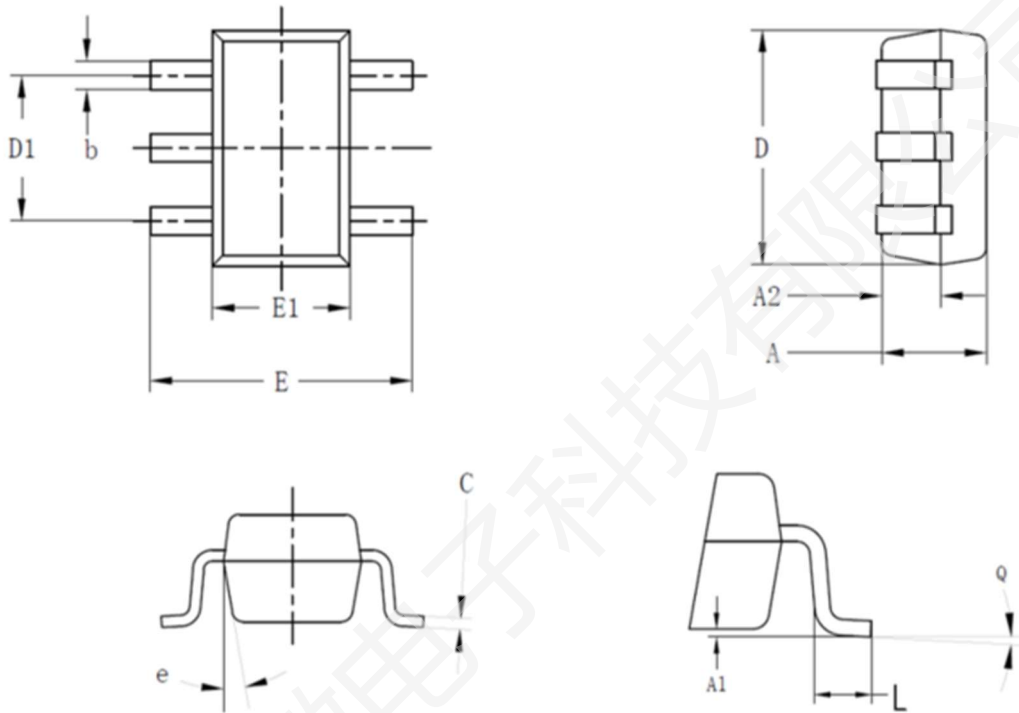

COMMON IN DIMENSION (MM)			
PKG	SOT-353		
Symbol	Min	Nom	Max
A	0.910	0.960	1.010
A1	0.010	0.060	0.150
A2	0.500	0.540	0.600
b	0.200	0.250	0.310
C	0.100	0.110	0.120
D	2.050	2.100	2.250
D1	1.250	1.300	1.350
E	2.300	2.400	2.500
E1	1.200	1.260	1.350
L	0.260	0.360	0.460
e	10°		
Q	0°	4°	8°

### DFN1x1-4L Package

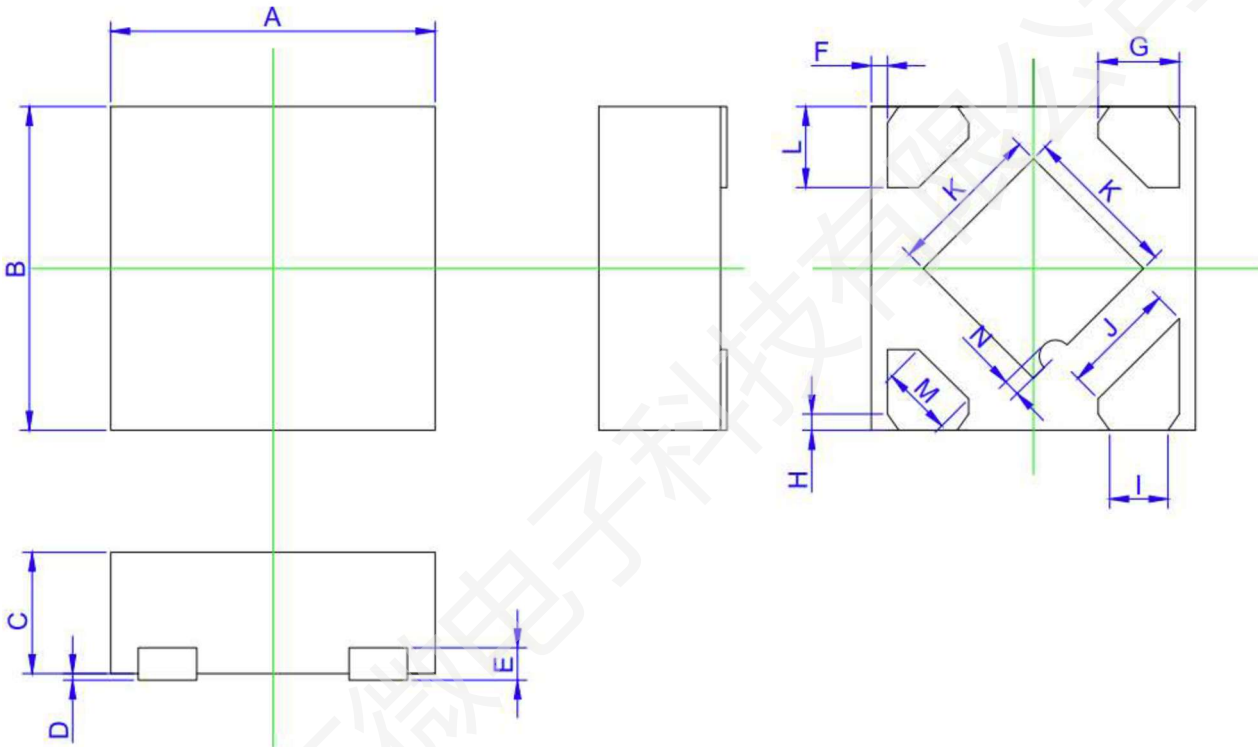

符号	标准	下公差	上公差	下限值	上限值
A	1.0	0.03	0.03	0.97	1.03
B	1.0	0.03	0.03	0.97	1.03
C	0.375	0.03	0.03	0.345	0.405
D	0.02	0.005	0.02	0.015	0.04
E			0.10REF		
F			0.05REF		
G			0.25REF		
H			0.05REF		
I			0.18REF		
J			0.34REF		
K			0.48REF		
L			0.25REF		
M			0.245REF		
N			0.06REF		

**Revision History:**

Revision	Date	Descriptions
Rev 0.1	Jun. 2023	Initial Version
Rev 1.0	Oct. 2023	Formal Version
Rev 1.1	Jun. 2024	Update new package
Rev 1.2	May. 2026	Update Electrical Characteristics、Package Outline

**DISCLAIMER:**

- The product is not intended for use in applications that require extraordinary levels of quality and reliability, such as military, aviation/aerospace and life-support systems or other applications whose failure can be reasonably expected to result in serious physical or material damage.
- Lewa-Micro assumes no responsibility for equipment failures that result from using products at parameters that exceed, even momentarily, rated values (such as maximum ratings, operating condition ranges, or other parameters) listed in products specifications of any Lewa-Micro products described or contained herein.
- Specifications of any and all Lewa-Micro products described or contained herein stipulate the performance, characteristics, and functions of the described products in the independent state, and are not guarantees of the performance, characteristics, and functions of the described products as mounted in the customer's products or equipment. To verify symptoms and states that cannot be evaluated in an independent device, the customer should always evaluate and test devices mounted in the customer's products or equipment.
- Lewa-Micro strives to supply high-quality and high-reliability products. However, any and all semiconductor products have a certain probability of failure. It is possible that these probabilistic failures could give rise to accidents or events that could endanger human lives, that could give rise to smoke or fire, or that could cause damage to other property. When designing equipment, adopt safety measures so that these kinds of accidents or events cannot occur. Such measures including but not limited to protective circuits and error prevention circuits for safe design, redundant design, and structural design.
- To comply with the compliance requirements of relevant export control laws and regulations, if any Lewa-Micro product (including technical data and services) stated herein is subject to relevant export control laws and regulations, it is recommended that the customer apply for and obtain an export license from the competent authority in advance in accordance with the requirements of relevant laws, and do not conduct export activities without obtaining the license. If the customer fails to comply with the aforementioned compliance requirements, all legal liabilities arising therefrom shall be borne solely by the customer.
- To protect Lewa-Micro's intellectual property rights and the security of commercial information, without the prior written permission of Lewa-Micro, no part of this document shall be reproduced or disseminated in any form or by any means (including photocopying, recording, and other electronic or mechanical means, as well as various information storage and retrieval systems). For unauthorized reproduction or dissemination, Lewa-Micro reserves the right to pursue legal liability.
- Information (including circuit diagrams and circuit parameters) herein is for example only; it is not guaranteed for volume production. Lewa-Micro believes information herein is accurate and reliable, but no guarantees are made or implied regarding its use or any infringements of intellectual property rights or other rights of third parties.
- Any and all information described or contained herein are subject to change without notice due to product/technology improvement, etc.

Mailing Address: Unit 02&04&05, 10th Floor, Building 5, No.666 Shengxia Road, No.122 Yindong Road,  
China (Shanghai) Pilot Free Trade Zone  
Shanghai Lewa Micro-electronics Technology Co., Ltd