

## TPD2E2U06-Q1 Automotive Dual-Channel High-Speed ESD Protection Device

### 1 Features

- AEC-Q101 Qualified
- IEC 61000-4-2 Level 4 ESD Protection
  - ±25-kV (Contact Discharge)
  - ±30-kV (Air-gap Discharge)
- ISO 10605 (330 pF, 330 Ω) ESD Protection
  - ±20-kV (Contact Discharge)
  - ±25-kV (Air-gap Discharge)
- IO Capacitance 1.5-pF (Typical)
- DC Breakdown Voltage 6.5 V (Minimum)
- Ultra-Low Leakage Current 10-nA (Maximum)
- Low ESD Clamping Voltage
- Industrial Temperature Range: –40°C to +125°C
- Small Easy-to-Route DBZ and DCK Packages

### 2 Applications

- End Equipment
  - Head Units
  - Rear Seat Entertainment
  - Telematics
  - Navigation Modules
  - Media Interfaces
- Interfaces
  - USB 2.0
  - Ethernet
  - Antenna
  - LVDS
  - I<sup>2</sup>C

### 3 Description

The TPD2E2U06-Q1 is a Transient Voltage Suppressor (TVS) Electrostatic Discharge (ESD) protection diode array with low capacitance. This dual-channel ESD protection diode is rated to dissipate ESD strikes above the maximum level specified in the IEC 61000-4-2 international standard. The 1.5-pF line capacitance of the TPD2E2U06-Q1 makes it ideal for protecting interfaces such as USB 2.0, Ethernet, LVDS, Antenna, and I<sup>2</sup>C.

Device Information<sup>(1)</sup>

PART NUMBER	PACKAGE	BODY SIZE (NOM)
TPD2E2U06-Q1	SOT23 (3)	2.92 mm × 1.30 mm
TPD2E2U06-Q1	SC70 (3)	2.00 mm × 1.25 mm

(1) For all available packages, see the orderable addendum at the end of the datasheet.

Simplified Schematic

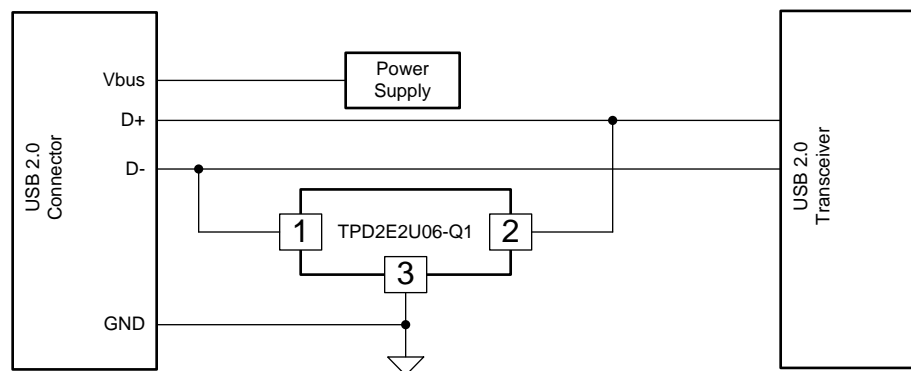

Copyright © 2016, Texas Instruments Incorporated



## Table of Contents

<b>1 Features</b> .....	<b>1</b>	7.3 Feature Description .....	<b>8</b>
<b>2 Applications</b> .....	<b>1</b>	7.4 Device Functional Modes .....	<b>9</b>
<b>3 Description</b> .....	<b>1</b>	<b>8 Application and Implementation</b> .....	<b>10</b>
<b>4 Revision History</b> .....	<b>2</b>	8.1 Application Information .....	<b>10</b>
<b>5 Pin Configuration and Functions</b> .....	<b>3</b>	8.2 Typical Application .....	<b>10</b>
<b>6 Specifications</b> .....	<b>4</b>	<b>9 Power Supply Recommendations</b> .....	<b>12</b>
6.1 Absolute Maximum Ratings .....	<b>4</b>	<b>10 Layout</b> .....	<b>12</b>
6.2 ESD Ratings—AEC Specification .....	<b>4</b>	10.1 Layout Guidelines .....	<b>12</b>
6.3 ESD Ratings—IEC Specification .....	<b>4</b>	10.2 Layout Example .....	<b>12</b>
6.4 ESD Ratings—ISO Specification .....	<b>4</b>	<b>11 Device and Documentation Support</b> .....	<b>13</b>
6.5 Recommended Operating Conditions .....	<b>4</b>	11.1 Documentation Support .....	<b>13</b>
6.6 Thermal Information .....	<b>4</b>	11.2 Community Resources .....	<b>13</b>
6.7 Electrical Characteristics .....	<b>5</b>	11.3 Trademarks .....	<b>13</b>
6.8 Typical Characteristics .....	<b>6</b>	11.4 Electrostatic Discharge Caution .....	<b>13</b>
<b>7 Detailed Description</b> .....	<b>8</b>	11.5 Glossary .....	<b>13</b>
7.1 Overview .....	<b>8</b>	<b>12 Mechanical, Packaging, and Orderable Information</b> .....	<b>13</b>
7.2 Functional Block Diagram .....	<b>8</b>		

## 4 Revision History

NOTE: Page numbers for previous revisions may differ from page numbers in the current version.

<b>Changes from Revision C (March 2016) to Revision D</b>	<b>Page</b>
• Updated <a href="#">Features</a> , <a href="#">Applications</a> and <a href="#">Description</a> .....	<b>1</b>
• Updated <a href="#">ESD Ratings—AEC Specification</a> table .....	<b>1</b>

<b>Changes from Revision B (December 2014) to Revision C</b>	<b>Page</b>
• Added DCK package .....	<b>1</b>
• Added DCK thermal data in <a href="#">Thermal Information</a> table .....	<b>1</b>

  

<b>Changes from Revision A (December 2014) to Revision B</b>	<b>Page</b>
• Added temperature specification to $V_{BR}$ TEST CONDITIONS. ....	<b>5</b>

<b>Changes from Original (December 2014) to Revision A</b>	<b>Page</b>
• Initial release of full document. ....	<b>1</b>

## 5 Pin Configuration and Functions

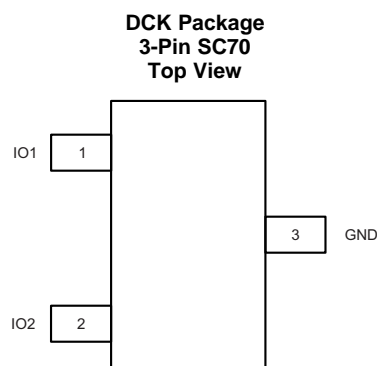
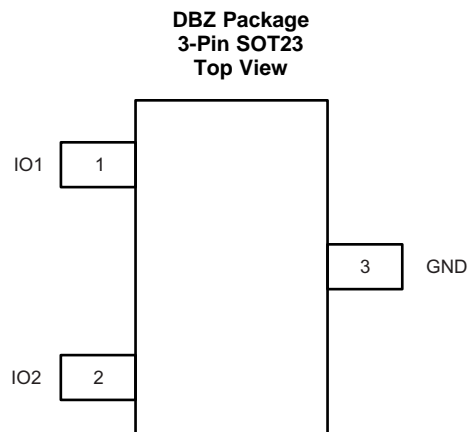

### Pin Functions

PIN		I/O	DESCRIPTION
NO.	NAME		
1	IO1	I/O	The IO1 and IO2 pins are an ESD protected channel. Connect these pins to the data line as close to the connector as possible.
2	IO2	I/O	
3	GND	G	The GND (ground) pin is connected to ground.

## 6 Specifications

### 6.1 Absolute Maximum Ratings

over operating free-air temperature range (unless otherwise noted)<sup>(1)</sup>

		MIN	MAX	UNIT
$I_{PP}$	Peak pulse current ( $t_p = 8/20 \mu\text{s}$ )		5.5 <sup>(2)</sup>	A
$P_{PP}$	Peak pulse power ( $t_p = 8/20 \mu\text{s}$ )		75 <sup>(2)</sup>	W
$T_J$	Junction temperature	–40	125	°C
$T_{stg}$	Storage temperature	–65	150	°C

- (1) Stresses beyond those listed under *Absolute Maximum Ratings* may cause permanent damage to the device. These are stress ratings only, which do not imply functional operation of the device at these or any other conditions beyond those indicated under *Recommended Operating Conditions*. Exposure to absolute-maximum-rated conditions for extended periods may affect device reliability.
- (2) Measured at 25°C.

### 6.2 ESD Ratings—AEC Specification

			VALUE	UNIT
$V_{(ESD)}$	Electrostatic discharge	Human body model (HBM), per AEC Q100-002 <sup>(1)</sup>	±10000	V
		Charged device model (CDM), per AEC Q100-011	±1000	

- (1) AAEC Q100-002 indicates that HBM stressing shall be in accordance with the ANSI/ESDA/JEDEC JS-001 specification.

### 6.3 ESD Ratings—IEC Specification

			VALUE	UNIT
$V_{(ESD)}$	Electrostatic discharge	IEC 61000-4-2	Contact discharge	V
			Air-gap discharge	

### 6.4 ESD Ratings—ISO Specification

			VALUE	UNIT
$V_{(ESD)}$	Electrostatic discharge	ISO 10605 (330 pF, 330 Ω)	Contact discharge	V
			Air-gap discharge	

### 6.5 Recommended Operating Conditions

over operating free-air temperature range (unless otherwise noted)

		MIN	MAX	UNIT
$V_{IO}$	Input pin voltage	0	5.5	V
$T_A$	Operating free air temperature	–40	125	°C

### 6.6 Thermal Information

THERMAL METRIC <sup>(1)</sup>		TPD2E2U06-Q1		UNIT
		DBZ (SOT23)	DCK (SC70)	
		3 PINS	3 PINS	
$R_{\theta JA}$	Junction-to-ambient thermal resistance	439.5	308.3	°C/W
$R_{\theta JC(top)}$	Junction-to-case (top) thermal resistance	194.9	170.7	°C/W
$R_{\theta JB}$	Junction-to-board thermal resistance	173.9	89.2	°C/W
$\Psi_{JT}$	Junction-to-top characterization parameter	53.7	34.2	°C/W
$\Psi_{JB}$	Junction-to-board characterization parameter	172	88.6	°C/W
$R_{\theta JC(bot)}$	Junction-to-case (bottom) thermal resistance	N/A	N/A	°C/W

- (1) For more information about traditional and new thermal metrics, see the *Semiconductor and IC Package Thermal Metrics* application report, [SPRA953](#).

## 6.7 Electrical Characteristics

over operating free-air temperature range (unless otherwise noted)

PARAMETER		TEST CONDITIONS	MIN	TYP	MAX	UNIT
$V_{RWM}$	Reverse stand-off voltage	$I_{IO} < 10 \mu A$			5.5	V
$V_{CLAMP}$	IO to GND	$I_{PP} = 1 A, TLP^{(1)(2)}$		9.7		V
		$I_{PP} = 5 A, TLP^{(1)(2)}$		12.4		
$V_{CLAMP}$	GND to IO	$I_{PP} = 1 A, TLP^{(1)(2)}$		1.9		V
		$I_{PP} = 5 A, TLP^{(1)(2)}$		4		
$R_{DYN}$	Dynamic resistance	IO to GND <sup>(3)(2)</sup>		0.6		$\Omega$
		GND to IO <sup>(3)(2)</sup>		0.4		
$C_L$	Line capacitance	$f = 1 MHz, V_{BIAS} = 2.5 V^{(2)}$		1.5	1.9	pF
$C_{CROSS}$	Channel-to-channel input capacitance	Pin 3 = 0 V, $f = 1 MHz, V_{BIAS} = 2.5 V$ , between channel pins <sup>(2)</sup>		0.02	0.03	pF
$\Delta_{CL}$	Variation of channel input capacitance	Pin 3 = 0 V, $f = 1 MHz, V_{BIAS} = 2.5 V$ , Pin 1 to GND – Pin 2 to GND <sup>(2)</sup>		0.03	0.1	pF
$V_{BR}$	Break-down voltage	$I_{IO} = 1 mA^{(2)}$	6.5		8.5	V
$I_{LEAK}$	Leakage current	$V_{IO} = 2.5 V$		1	10	nA

(1) Transmission Line Pulse with 10-ns rise time, 100-ns width.

(2) Measured at 25°C.

 (3) Extraction of  $R_{DYN}$  Using least squares fit of TLP characteristics between  $I = 20 A$  and  $I = 30 A$ .

## 6.8 Typical Characteristics

Measured at  $T_A = 25^\circ\text{C}$  unless otherwise specified

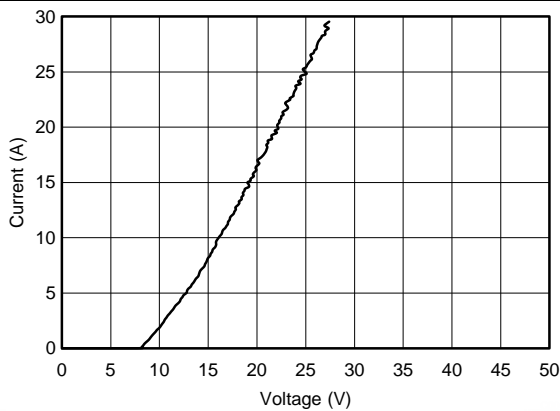

Figure 1. TLP, Data to GND

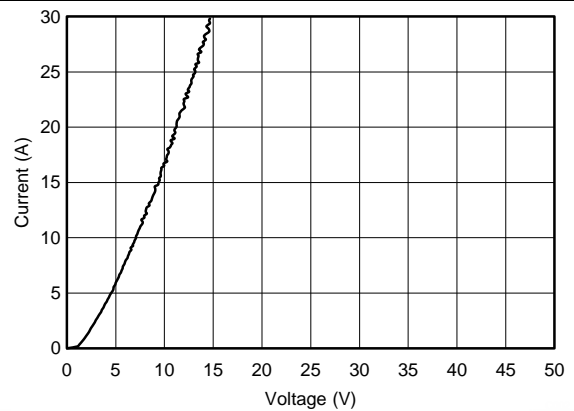

Figure 2. TLP, GND to Data

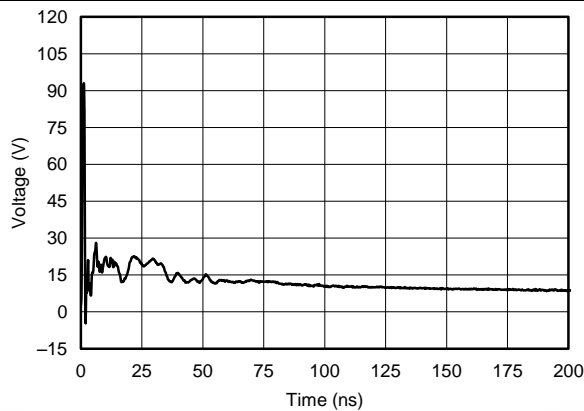

Figure 3. IEC 61000-4-2 Clamping Voltage, 8-kV Contact

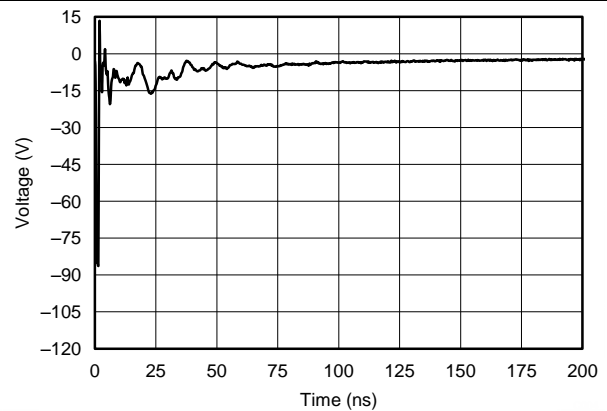

Figure 4. IEC 61000-4-2 Clamping Voltage, -8-kV Contact

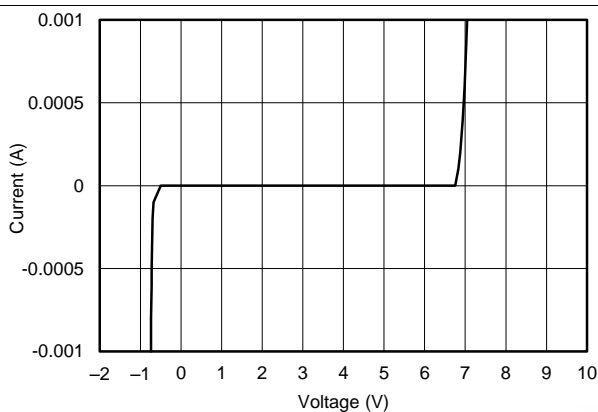

Figure 5. IV Curve,  $T_A = 25^\circ\text{C}$

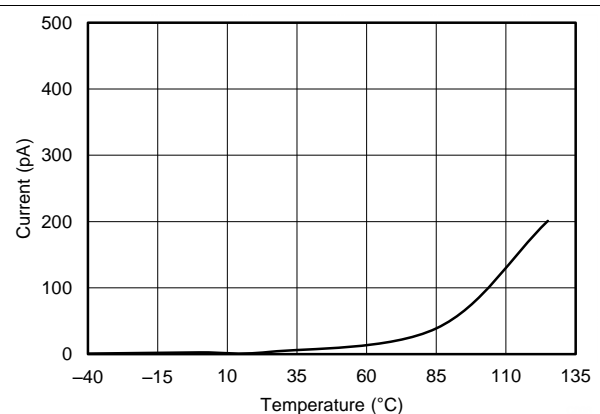

Figure 6.  $I_{\text{LEAK}}$  vs Temperature,  $V_{\text{IN}} = 2.5 \text{ V}$

### Typical Characteristics (continued)

Measured at  $T_A = 25^\circ\text{C}$  unless otherwise specified

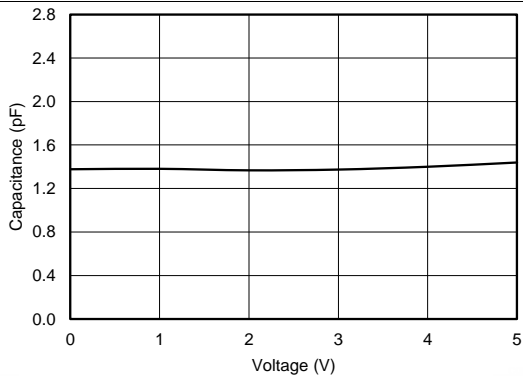

Figure 7. Capacitance Across  $V_{BIAS}$   
 $f = 1 \text{ MHz}$

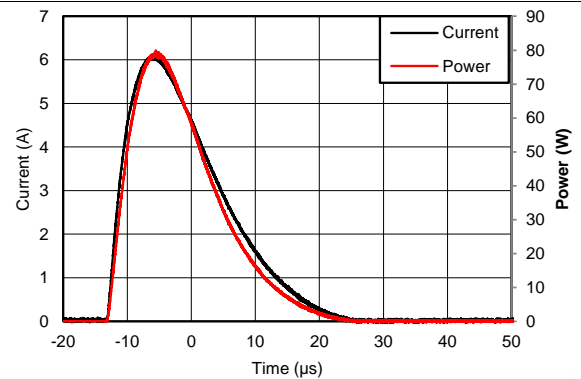

Figure 8. Surge Curve ( $t_p = 8/20 \mu\text{s}$ )  
IO TO GND

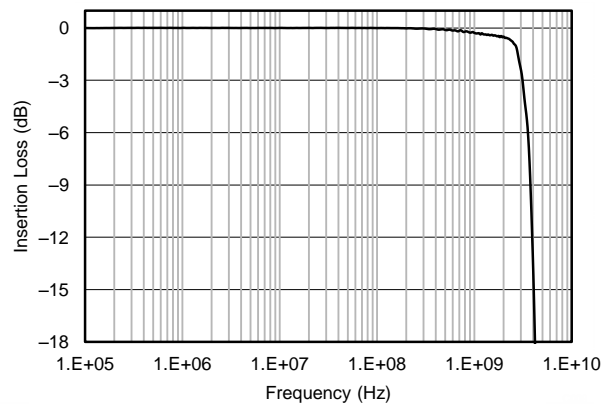

Figure 9. Insertion Loss

## 7 Detailed Description

### 7.1 Overview

The TPD2E2U06-Q1 device is a TVS ESD protection diode array with low capacitance. It is rated to dissipate ESD strikes above the maximum level specified in the IEC 61000-4-2 international standard. The 1.5-pF line capacitance makes it ideal for protecting interfaces such as USB 2.0, LVDS, Antenna, and I<sup>2</sup>C.

### 7.2 Functional Block Diagram

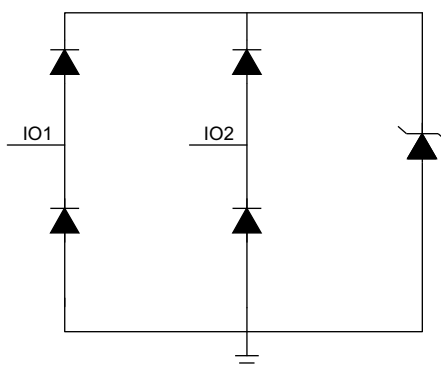

Copyright © 2016, Texas Instruments Incorporated

### 7.3 Feature Description

The TPD2E2U06-Q1 device is a TVS ESD protection diode array with low capacitance. It is rated to dissipate ESD strikes above the maximum level specified in the IEC 61000-4-2 international standard. The 1.5-pF line capacitance makes it ideal for protecting interfaces such as USB 2.0, LVDS, Antenna, and I<sup>2</sup>C.

#### 7.3.1 AEC-Q101 Qualified

This device is qualified to AEC-Q101 standards. It passes HBM H3B ( $\pm 8$  kV) and CDM C5 ( $\pm 1$  kV) ESD ratings and is qualified to operate from  $-40^{\circ}\text{C}$  to  $+125^{\circ}\text{C}$ .

#### 7.3.2 IEC 61000-4-2 Level 4

The I/O pins can withstand ESD events up to  $\pm 25$ -kV contact and  $\pm 30$ -kV air. An ESD-surge clamp diverts the current to ground.

#### 7.3.3 IO Capacitance

The capacitance between each I/O pin to ground is 1.5 pF. These capacitances support data rates in excess of 1.5 Gbps.

#### 7.3.4 DC Breakdown Voltage

The DC breakdown voltage of each I/O pin is a minimum of 6.5 V. This ensures that sensitive equipment is protected from surges above the reverse standoff voltage of 5.5 V.

#### 7.3.5 Ultra-Low Leakage Current

The I/O pins feature an ultra-low leakage current of 10 nA (Maximum) with a bias of 2.5 V.

#### 7.3.6 Low ESD Clamping Voltage

The I/O pins feature an ESD clamp that is capable of clamping the voltage to 9.7 V ( $I_{PP} = 1$  A).

#### 7.3.7 Industrial Temperature Range

This device is designed to operate from  $-40^{\circ}\text{C}$  to  $+125^{\circ}\text{C}$ .

## Feature Description (continued)

### 7.3.8 Small Easy-to-Route Packages

The layout of this device makes it simple and easy to add protection to an existing layout. The packages offers flow-through routing, requiring minimal modification to an existing layout.

### 7.4 Device Functional Modes

The TPD2E2U06-Q1 device is a passive integrated circuit that triggers when voltages are above  $V_{BR}$  or below the lower diodes  $V_f$  ( $-0.6$  V). During ESD events, voltages as high as  $\pm 30$  kV (air) can be directed to ground via the internal diode network. When the voltages on the protected line fall below the trigger levels of the TPD2E2U06-Q1 (usually within 10s of nano-seconds) the device reverts to passive.

## 8 Application and Implementation

### NOTE

Information in the following applications sections is not part of the TI component specification, and TI does not warrant its accuracy or completeness. TI's customers are responsible for determining suitability of components for their purposes. Customers should validate and test their design implementation to confirm system functionality.

### 8.1 Application Information

The TPD2E2U06-Q1 device is a diode type TVS which is typically used to provide a path to ground for dissipating ESD events on hi-speed signal lines between a human interface connector and a system. As the current from ESD passes through the TVS, only a small voltage drop is present across the diode. This is the voltage presented to the protected IC. The low  $R_{DYN}$  of the triggered TVS holds this voltage,  $V_{CLAMP}$ , to a safe level for the protected IC.

### 8.2 Typical Application

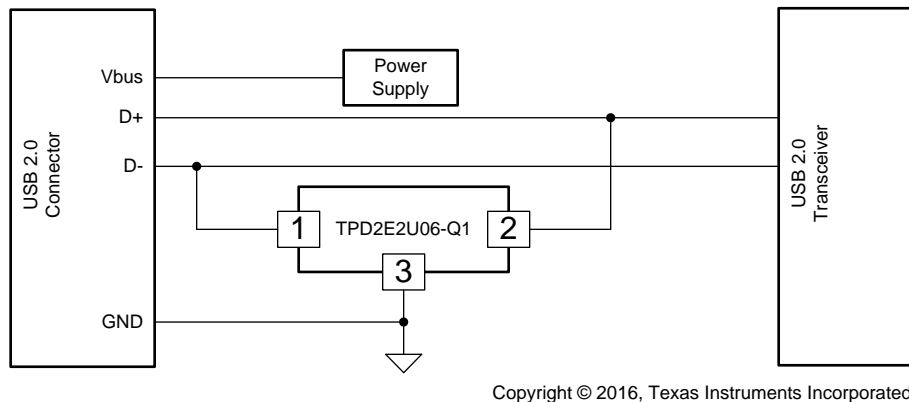

**Figure 10. Typical USB Application Diagram**

#### 8.2.1 Design Requirements

For this design example, one TPD2E2U06-Q1 device will be used in a USB 2.0 application. This will provide complete port protection.

Given the USB 2.0 application, the parameters listed in [Table 1](#) are known.

**Table 1. Design Parameters**

DESIGN PARAMETER	VALUE
Signal range on pins 1 or 2	0 V to 3.3 V
Operating frequency	240 MHz

## 8.2.2 Detailed Design Procedure

### 8.2.2.1 Signal Range

The TPD2E2U06-Q1 device has 2 identical protection channels for signal lines. The symmetry of the device provides flexibility when selecting which of the 2 I/O channels will protect which signal lines. Any I/O will support a signal range of 0 to 5.5 V.

### 8.2.2.2 Operating Frequency

The TPD2E2U06-Q1 device has a capacitance of 1.5 pF (typical), supporting USB 2.0 data rates.

## 8.2.3 Application Curve

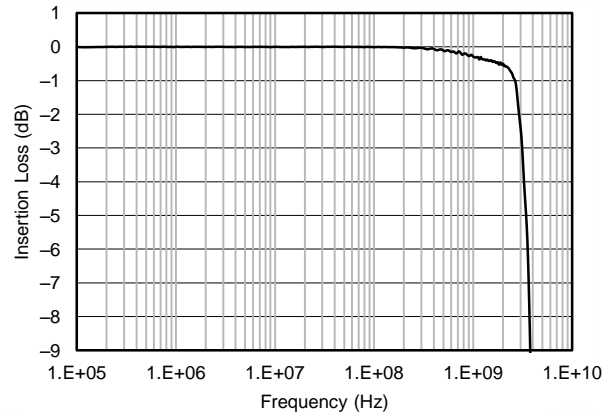

**Figure 11. Insertion Loss Graph**

## 9 Power Supply Recommendations

This device is a passive ESD protection device and there is no need to power it. Make sure that the maximum voltage specifications for each line are not violated.

## 10 Layout

### 10.1 Layout Guidelines

- The optimum placement is as close to the connector as possible.
  - EMI during an ESD event can couple from the trace being struck to other nearby unprotected traces, resulting in early system failures.
  - The PCB designer needs to minimize the possibility of EMI coupling by keeping any unprotected traces away from the protected traces which are between the TVS and the connector.
- Route the protected traces as straight as possible.
- Eliminate any sharp corners on the protected traces between the TVS and the connector by using rounded corners with the largest radii possible.
  - Electric fields tend to build up on corners, increasing EMI coupling.

### 10.2 Layout Example

This application is typical of a differential data pair application, such as USB 2.0.

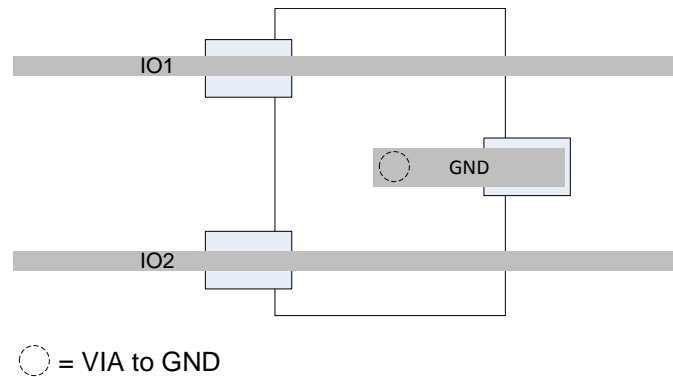

**Figure 12. Routing with DBZ Package**

## 11 Device and Documentation Support

### 11.1 Documentation Support

#### 11.1.1 Related Documentation

For related documentation see the following:

- *Reading and Understanding an ESD Protection Datasheet*, [SLLA305](#)
- *ESD Layout Guide*, [SLVA680](#)
- *TPD2E2U06QEVM User's Guide*, [SLVUAC6](#)

### 11.2 Community Resources

The following links connect to TI community resources. Linked contents are provided "AS IS" by the respective contributors. They do not constitute TI specifications and do not necessarily reflect TI's views; see TI's [Terms of Use](#).

**TI E2E™ Online Community** *TI's Engineer-to-Engineer (E2E) Community*. Created to foster collaboration among engineers. At [e2e.ti.com](#), you can ask questions, share knowledge, explore ideas and help solve problems with fellow engineers.

**Design Support** *TI's Design Support* Quickly find helpful E2E forums along with design support tools and contact information for technical support.

### 11.3 Trademarks

E2E is a trademark of Texas Instruments.  
All other trademarks are the property of their respective owners.

### 11.4 Electrostatic Discharge Caution



These devices have limited built-in ESD protection. The leads should be shorted together or the device placed in conductive foam during storage or handling to prevent electrostatic damage to the MOS gates.

### 11.5 Glossary

[SLYZ022](#) — *TI Glossary*.

This glossary lists and explains terms, acronyms, and definitions.

## 12 Mechanical, Packaging, and Orderable Information

The following pages include mechanical, packaging, and orderable information. This information is the most current data available for the designated devices. This data is subject to change without notice and revision of this document. For browser-based versions of this data sheet, refer to the left-hand navigation.

**PACKAGING INFORMATION**

Orderable Device	Status (1)	Package Type	Package Drawing	Pins	Package Qty	Eco Plan (2)	Lead/Ball Finish (6)	MSL Peak Temp (3)	Op Temp (°C)	Device Marking (4/5)	Samples
TPD2E2U06QDBZRQ1	ACTIVE	SOT-23	DBZ	3	3000	Green (RoHS & no Sb/Br)	NIPDAU	Level-2-260C-1 YEAR	-40 to 125	22U6Q	<a href="#">Samples</a>
TPD2E2U06QDCKRQ1	ACTIVE	SC70	DCK	3	3000	Green (RoHS & no Sb/Br)	NIPDAU	Level-2-260C-1 YEAR	-40 to 125	11X	<a href="#">Samples</a>

(1) The marketing status values are defined as follows:

**ACTIVE:** Product device recommended for new designs.

**LIFEBUY:** TI has announced that the device will be discontinued, and a lifetime-buy period is in effect.

**NRND:** Not recommended for new designs. Device is in production to support existing customers, but TI does not recommend using this part in a new design.

**PREVIEW:** Device has been announced but is not in production. Samples may or may not be available.

**OBSELETE:** TI has discontinued the production of the device.

(2) **RoHS:** TI defines "RoHS" to mean semiconductor products that are compliant with the current EU RoHS requirements for all 10 RoHS substances, including the requirement that RoHS substance do not exceed 0.1% by weight in homogeneous materials. Where designed to be soldered at high temperatures, "RoHS" products are suitable for use in specified lead-free processes. TI may reference these types of products as "Pb-Free".

**RoHS Exempt:** TI defines "RoHS Exempt" to mean products that contain lead but are compliant with EU RoHS pursuant to a specific EU RoHS exemption.

**Green:** TI defines "Green" to mean the content of Chlorine (Cl) and Bromine (Br) based flame retardants meet JS709B low halogen requirements of <=1000ppm threshold. Antimony trioxide based flame retardants must also meet the <=1000ppm threshold requirement.

(3) MSL, Peak Temp. - The Moisture Sensitivity Level rating according to the JEDEC industry standard classifications, and peak solder temperature.

(4) There may be additional marking, which relates to the logo, the lot trace code information, or the environmental category on the device.

(5) Multiple Device Markings will be inside parentheses. Only one Device Marking contained in parentheses and separated by a "~" will appear on a device. If a line is indented then it is a continuation of the previous line and the two combined represent the entire Device Marking for that device.

(6) Lead/Ball Finish - Orderable Devices may have multiple material finish options. Finish options are separated by a vertical ruled line. Lead/Ball Finish values may wrap to two lines if the finish value exceeds the maximum column width.

**Important Information and Disclaimer:**The information provided on this page represents TI's knowledge and belief as of the date that it is provided. TI bases its knowledge and belief on information provided by third parties, and makes no representation or warranty as to the accuracy of such information. Efforts are underway to better integrate information from third parties. TI has taken and continues to take reasonable steps to provide representative and accurate information but may not have conducted destructive testing or chemical analysis on incoming materials and chemicals. TI and TI suppliers consider certain information to be proprietary, and thus CAS numbers and other limited information may not be available for release.

In no event shall TI's liability arising out of such information exceed the total purchase price of the TI part(s) at issue in this document sold by TI to Customer on an annual basis.

**OTHER QUALIFIED VERSIONS OF TPD2E2U06-Q1 :**

- Catalog: [TPD2E2U06](#)

## NOTE: Qualified Version Definitions:

- Catalog - TI's standard catalog product

**TAPE AND REEL INFORMATION**

**QUADRANT ASSIGNMENTS FOR PIN 1 ORIENTATION IN TAPE**

\*All dimensions are nominal

Device	Package Type	Package Drawing	Pins	SPQ	Reel Diameter (mm)	Reel Width W1 (mm)	A0 (mm)	B0 (mm)	K0 (mm)	P1 (mm)	W (mm)	Pin1 Quadrant
TPD2E2U06QDBZRQ1	SOT-23	DBZ	3	3000	180.0	8.4	3.15	2.77	1.22	4.0	8.0	Q3
TPD2E2U06QDCKRQ1	SC70	DCK	3	3000	178.0	9.0	2.4	2.5	1.2	4.0	8.0	Q3

**TAPE AND REEL BOX DIMENSIONS**

\*All dimensions are nominal

Device	Package Type	Package Drawing	Pins	SPQ	Length (mm)	Width (mm)	Height (mm)
TPD2E2U06QDBZRQ1	SOT-23	DBZ	3	3000	213.0	191.0	35.0
TPD2E2U06QDCKRQ1	SC70	DCK	3	3000	180.0	180.0	18.0

## GENERIC PACKAGE VIEW

**DBZ 3**

**SOT-23 - 1.12 mm max height**

SMALL OUTLINE TRANSISTOR

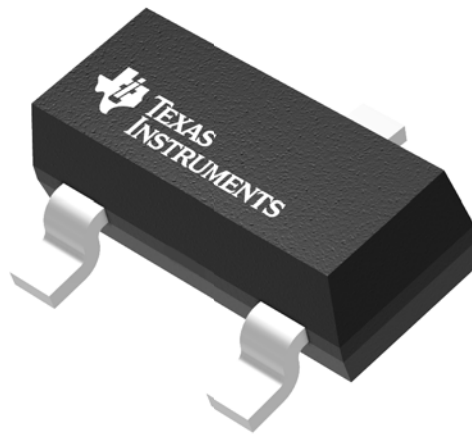

Images above are just a representation of the package family, actual package may vary.  
Refer to the product data sheet for package details.

4203227/C

DBZ0003A



# PACKAGE OUTLINE

SOT-23 - 1.12 mm max height

SMALL OUTLINE TRANSISTOR

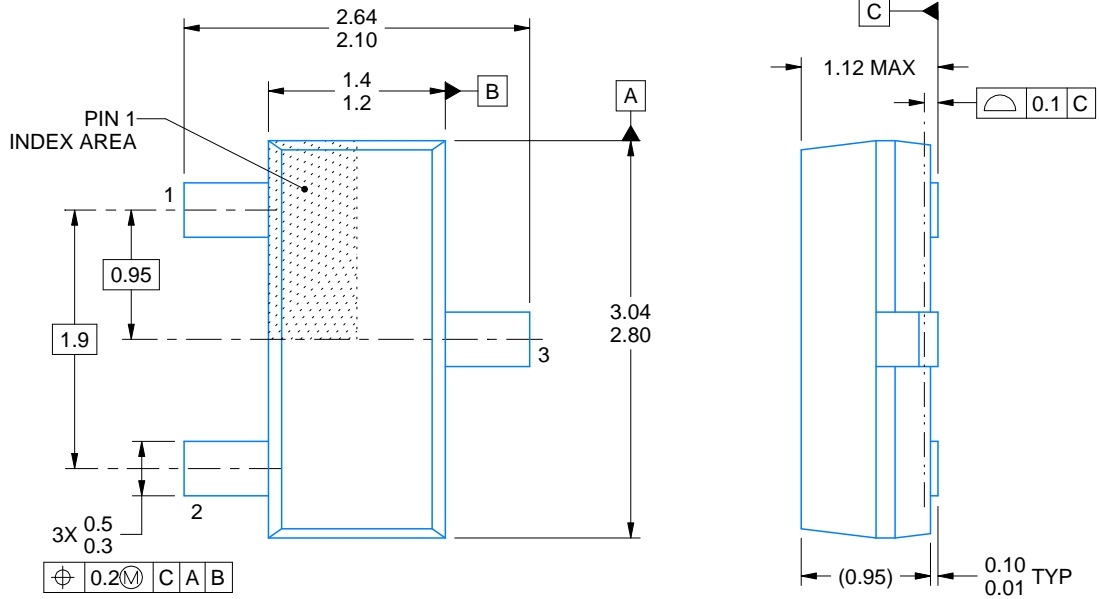

4214838/C 04/2017

NOTES:

1. All linear dimensions are in millimeters. Any dimensions in parenthesis are for reference only. Dimensioning and tolerancing per ASME Y14.5M.
2. This drawing is subject to change without notice.
3. Reference JEDEC registration TO-236, except minimum foot length.

# EXAMPLE BOARD LAYOUT

DBZ0003A

SOT-23 - 1.12 mm max height

SMALL OUTLINE TRANSISTOR

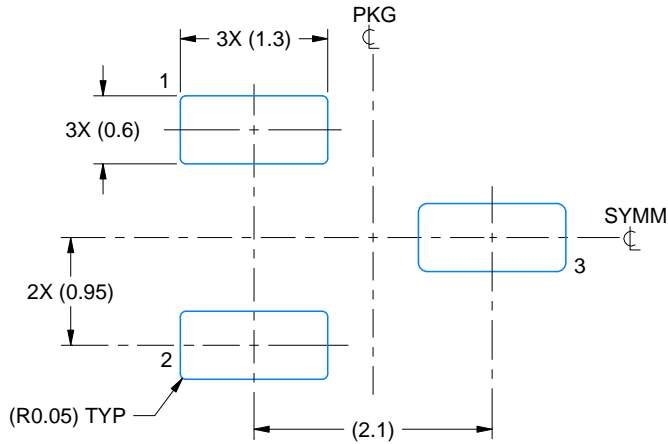

LAND PATTERN EXAMPLE  
SCALE:15X

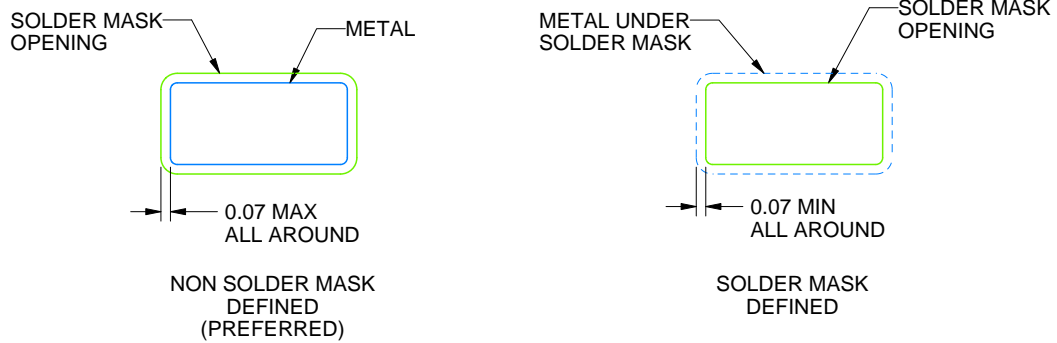

SOLDER MASK DETAILS

4214838/C 04/2017

NOTES: (continued)

4. Publication IPC-7351 may have alternate designs.
5. Solder mask tolerances between and around signal pads can vary based on board fabrication site.

# EXAMPLE STENCIL DESIGN

DBZ0003A

SOT-23 - 1.12 mm max height

SMALL OUTLINE TRANSISTOR



SOLDER PASTE EXAMPLE  
BASED ON 0.125 THICK STENCIL  
SCALE:15X

4214838/C 04/2017

NOTES: (continued)

6. Laser cutting apertures with trapezoidal walls and rounded corners may offer better paste release. IPC-7525 may have alternate design recommendations.
7. Board assembly site may have different recommendations for stencil design.

DCK0003A

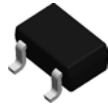

# PACKAGE OUTLINE

SOT-SC70 - 1.1 max height

SMALL OUTLINE TRANSISTOR SC70

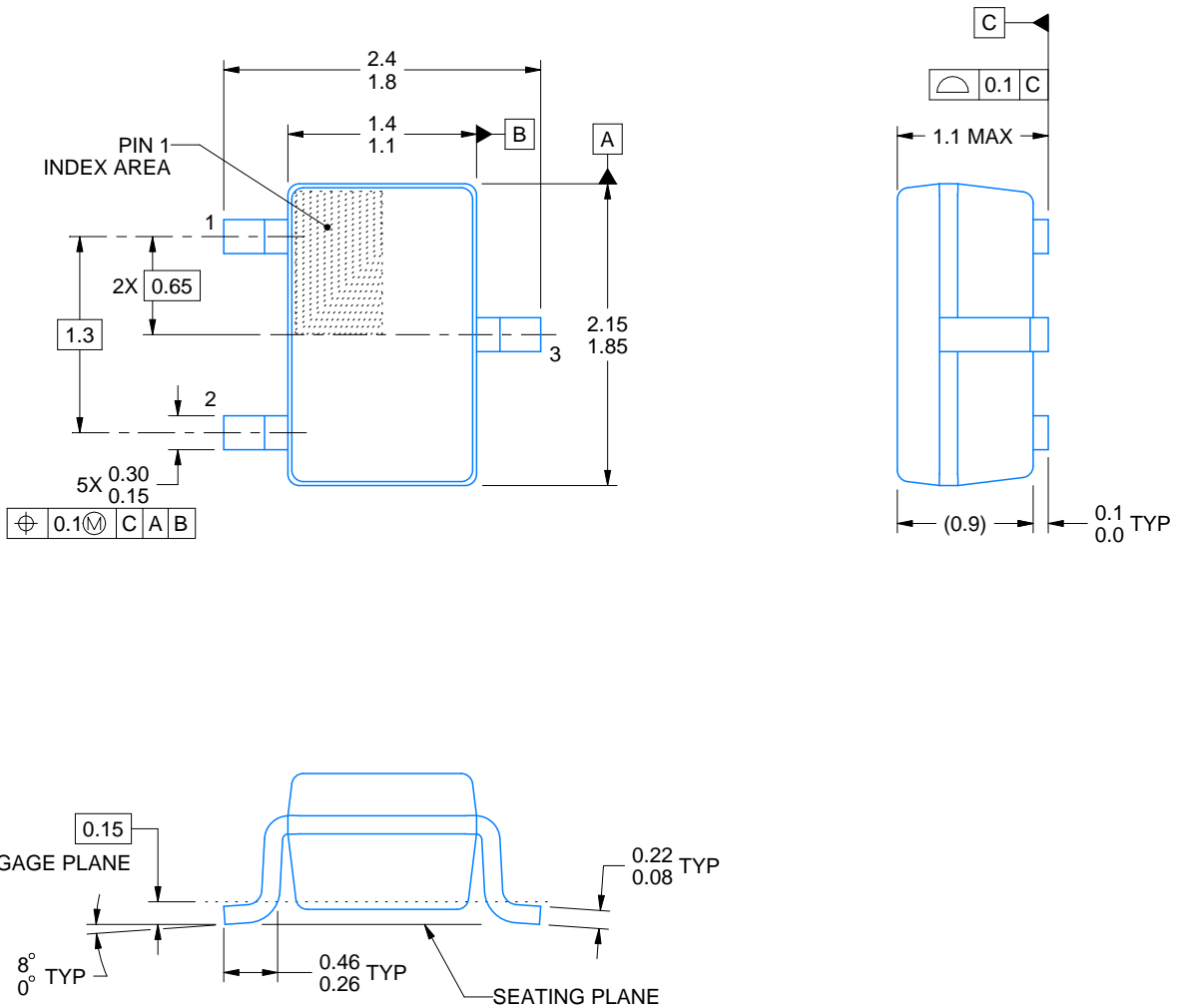

4220745/A 03/2019

NOTES:

1. All linear dimensions are in millimeters. Any dimensions in parenthesis are for reference only. Dimensioning and tolerancing per ASME Y14.5M.
2. This drawing is subject to change without notice.
3. Reference JEDEC MO-203.

# EXAMPLE BOARD LAYOUT

DCK0003A

SOT-SC70 - 1.1 max height

SMALL OUTLINE TRANSISTOR SC70

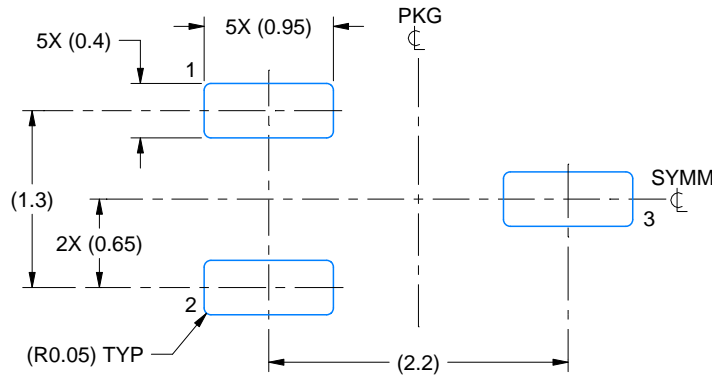

LAND PATTERN EXAMPLE  
EXPOSED METAL SHOWN  
SCALE:18X

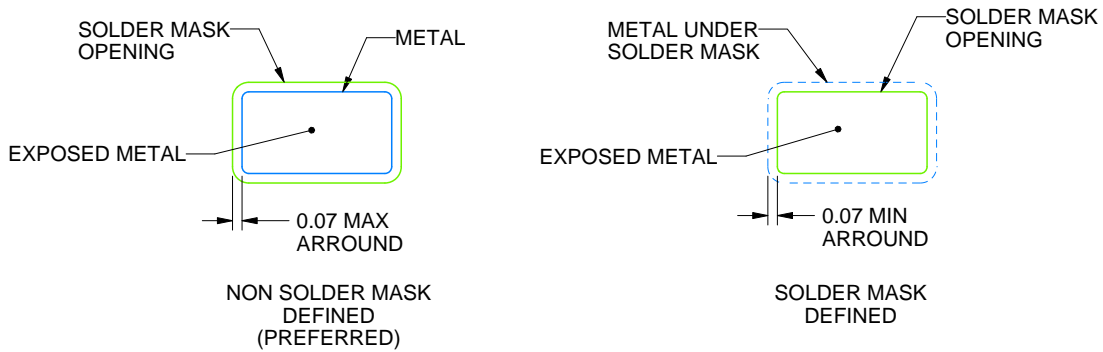

SOLDER MASK DETAILS

4220745/A 03/2019

NOTES: (continued)

- 4. Publication IPC-7351 may have alternate designs.
- 5. Solder mask tolerances between and around signal pads can vary based on board fabrication site.

# EXAMPLE STENCIL DESIGN

DCK0003A

SOT-SC70 - 1.1 max height

SMALL OUTLINE TRANSISTOR SC70

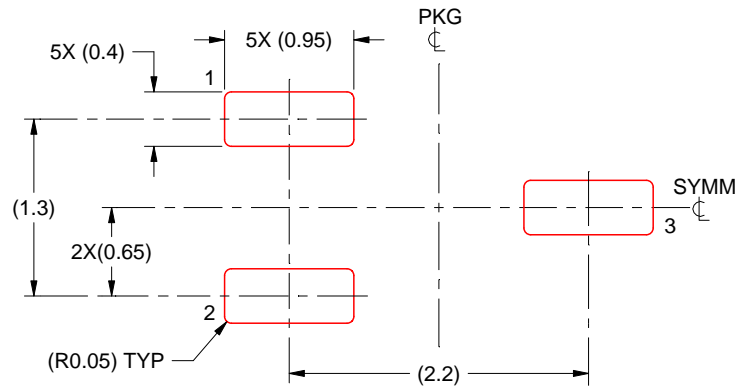

SOLDER PASTE EXAMPLE  
BASED ON 0.125 THICK STENCIL  
SCALE:18X

4220745/A 03/2019

NOTES: (continued)

6. Laser cutting apertures with trapezoidal walls and rounded corners may offer better paste release. IPC-7525 may have alternate design recommendations.
7. Board assembly site may have different recommendations for stencil design.

## IMPORTANT NOTICE AND DISCLAIMER

TI PROVIDES TECHNICAL AND RELIABILITY DATA (INCLUDING DATASHEETS), DESIGN RESOURCES (INCLUDING REFERENCE DESIGNS), APPLICATION OR OTHER DESIGN ADVICE, WEB TOOLS, SAFETY INFORMATION, AND OTHER RESOURCES "AS IS" AND WITH ALL FAULTS, AND DISCLAIMS ALL WARRANTIES, EXPRESS AND IMPLIED, INCLUDING WITHOUT LIMITATION ANY IMPLIED WARRANTIES OF MERCHANTABILITY, FITNESS FOR A PARTICULAR PURPOSE OR NON-INFRINGEMENT OF THIRD PARTY INTELLECTUAL PROPERTY RIGHTS.

These resources are intended for skilled developers designing with TI products. You are solely responsible for (1) selecting the appropriate TI products for your application, (2) designing, validating and testing your application, and (3) ensuring your application meets applicable standards, and any other safety, security, or other requirements. These resources are subject to change without notice. TI grants you permission to use these resources only for development of an application that uses the TI products described in the resource. Other reproduction and display of these resources is prohibited. No license is granted to any other TI intellectual property right or to any third party intellectual property right. TI disclaims responsibility for, and you will fully indemnify TI and its representatives against, any claims, damages, costs, losses, and liabilities arising out of your use of these resources.

TI's products are provided subject to TI's Terms of Sale ([www.ti.com/legal/termsofsale.html](http://www.ti.com/legal/termsofsale.html)) or other applicable terms available either on [ti.com](http://ti.com) or provided in conjunction with such TI products. TI's provision of these resources does not expand or otherwise alter TI's applicable warranties or warranty disclaimers for TI products.

Mailing Address: Texas Instruments, Post Office Box 655303, Dallas, Texas 75265  
Copyright © 2020, Texas Instruments Incorporated