

### Product Summary

- $V_{DS}$  100V
- $I_D$  80A
- $R_{DS(ON)}$  (at  $V_{GS}=10V$ )  $<6.0m\Omega$
- 100% EAS Tested
- 100%  $\nabla V_{DS}$  Tested

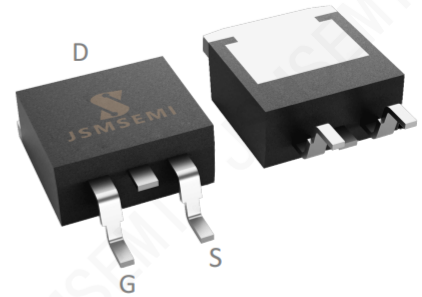

### General Description

- Split gate trench MOSFET technology
- Excellent package for heat dissipation
- High density cell design for low  $R_{DS(ON)}$
- Moisture Sensitivity Level 1
- Epoxy Meets UL 94 V-0 Flammability Rating
- Halogen Free

### Applications

- Power switching application
- Uninterruptible power supply
- DC-DC convertor
- Motor drivers

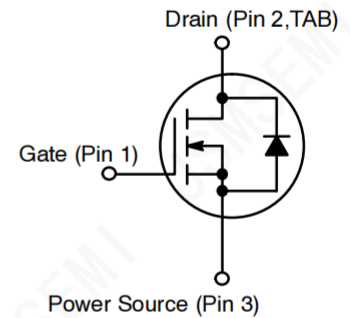

### Absolute Maximum Ratings ( $T_A=25^\circ C$ , unless otherwise specified)

Parameter	Symbol	Rating	Unit	
Drain-Source Voltage	$V_{DS}$	100	V	
Gate-Source Voltage	$V_{GS}$	$\pm 20$	V	
Continuous Drain Current	$I_D$	$T_C=25^\circ C$ <sup>Note1</sup>	80	A
		$T_C=100^\circ C$	80	A
		$T_A=25^\circ C$ <sup>Note4</sup>	17	A
Pulsed Drain Current <sup>Note2</sup>	$I_{D,pulse}$	600	A	
Avalanche energy, single pulse <sup>Note3</sup>	EAS	110	mJ	
Power Dissipation	$P_D$	$T_C=25^\circ C$	256	W
		$T_A=25^\circ C$ <sup>Note4</sup>	3.1	W
Operating and Storage Temperature Range	$T_J, T_{SGT}$	-55 to 150	$^\circ C$	

### Thermal Resistance

Parameter	Symbol	Min	Typ	Max	Unit
Thermal Resistance, Junction-to-Case	$R_{\theta JC}$	-	-	0.8	$^\circ C/W$
Thermal Resistance, Junction-to-Ambient <sup>Note4</sup>	$R_{\theta JA}$	-	-	40	$^\circ C/W$

### Ordering Information

Order number	Package	Marking	Operation Temperature Range	MSL Grade	Ship, Quantity	Green
IPB065N10N3G-JSM	TO-263	053N10BGH	-55 to 150 $^\circ C$	1	T&R, 800	Rohs

**Electrical Characteristics** ( $T_J=25^{\circ}\text{C}$ , unless otherwise specified)

Parameter	Symbol	Test Conditions	Min	Typ	Max	Unit
<b>Statistic Characteristics</b>						
Drain-Source Breakdown Voltage	$B_{VDSS}$	$V_{GS}=0V, I_D=250\mu A$	100	-	-	V
Gate-Body Leakage Current	$I_{GSS}$	$V_{GS}=\pm 20V, V_{DS}=0V$	-	-	$\pm 100$	nA
ZeroGate Voltage Drain Current	$I_{DSS}$	$V_{DS}=100V, V_{GS}=0V$	-	-	1	$\mu A$
Gate Threshold Voltage	$V_{GS(th)}$	$V_{DS}=V_{GS}, I_D=250\mu A$	2.2	3.0	3.8	V
Static Drain-Source On-Resistance	$R_{DS(ON)}$	$V_{GS}=10V, I_D=50A$	-	5.0	6.0	m $\Omega$
Gate Resistance	$R_g$	$f=1\text{MHz}$	-	1.5	-	$\Omega$
Forward Transconductance <sup>Note5</sup>	$g_{fs}$	$V_{DS}=5V, I_D=50A$	-	90	-	S
<b>Dynamic Characteristics<sup>Note5</sup></b>						
Input Capacitance	$C_{iss}$	$V_{GS}=0V, V_{DS}=50V, f=1\text{MHz}$	-	4646	-	pF
Output Capacitance	$C_{oss}$		-	580	-	pF
Reverse Transfer Capacitance	$C_{rss}$		-	30	-	pF
Turn-on Delay Time	$t_{d(on)}$	$V_{DS}=50V, I_D=50A$ $V_{GS}=10V, R_G=6\Omega$	-	53	-	ns
Rise Time	$t_r$		-	88	-	ns
Turn-off Delay Time	$t_{d(off)}$		-	85	-	ns
Fall Time	$t_f$		-	22	-	ns
<b>Gate Charge Characteristics</b>						
Total Gate Charge	$Q_g$	$V_{DS}=50V, V_{GS}=10V$ $I_D=50A$	-	69	-	nC
Gate to Source Charge	$Q_{gs}$		-	22	-	nC
Gate to Drain Charge	$Q_{gd}$		-	17	-	nC
<b>Reverse Diode Characteristics<sup>Note5</sup></b>						
Drain-Source Diode Forward Voltage	$V_{SD}$	$V_{GS}=0V, I_F=50A$	-	0.92	1.2	V
Reverse recovery time	$t_{rr}$	$I_F=50A, V_{DS}=50V$ $di/dt=100A/\mu s$	-	72	-	ns
Reverse recovery charge	$Q_{rr}$		-	138	-	nC

Notes:

- 1.Package limited
- 2.Pulse width limited by maximum junction temperature
3. $V_{DS}=50V, V_{GS}=10V, L=0.1\text{mH}$
4. $R_{\theta JA}$  is determined with the device mounted on a 1 in<sup>2</sup> pad 2 oz copper pad on a 1.5x1.5 in. board of FR-4 material
- 5.Guaranteed by design, not subject to production testing

**Electrical Characteristics Diagrams**

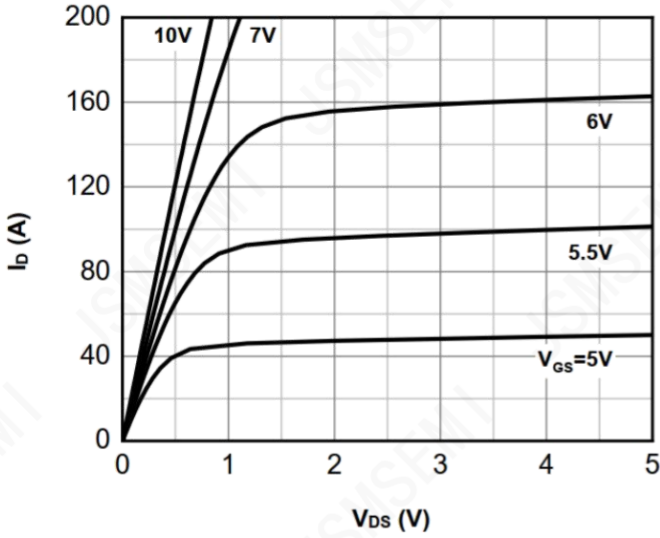

Figure 1: Typ. Output Characteristics

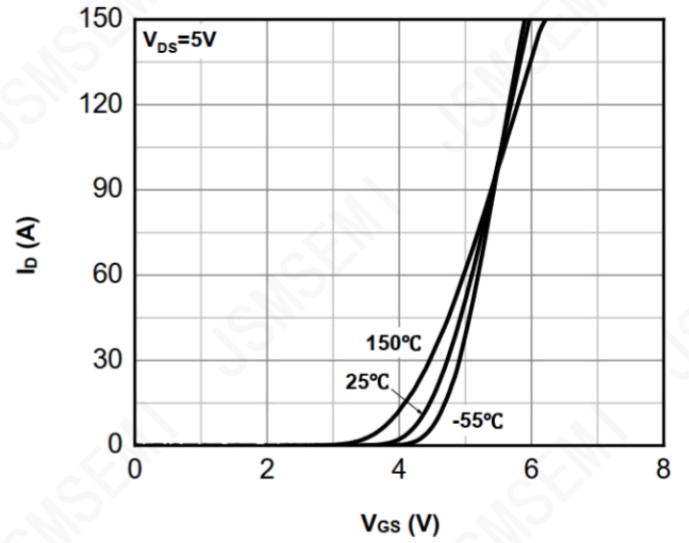

Figure 2: Typ. Transfer Characteristics

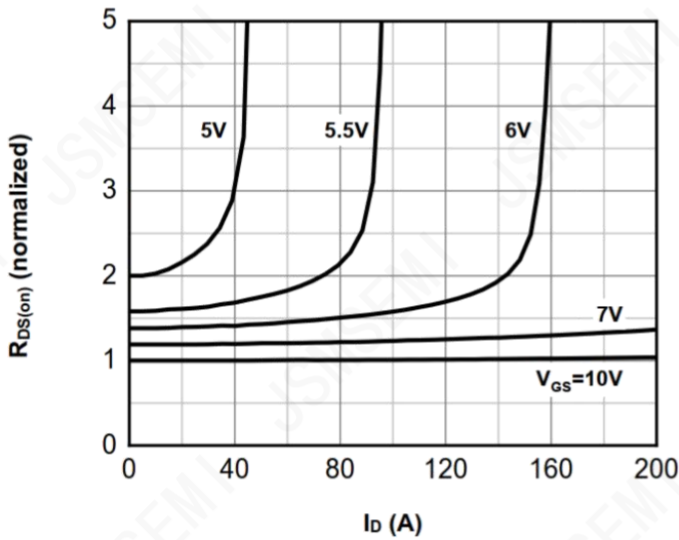

Figure 3: Normalized On-Resistance vs. Drain Current

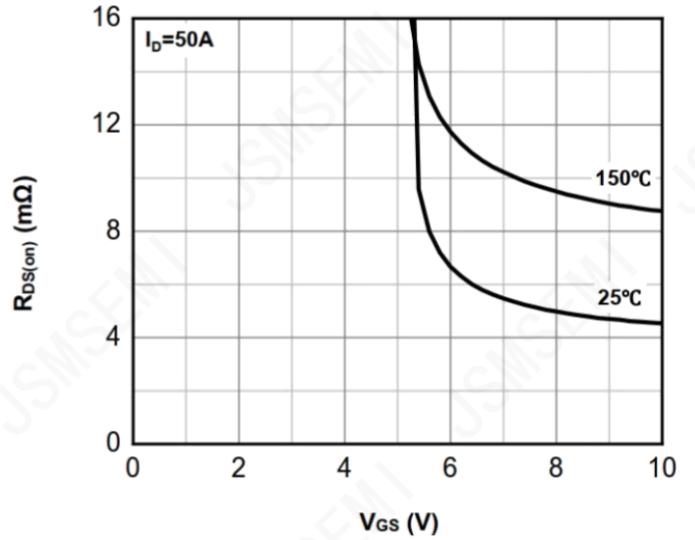

Figure 4: Typ. On-Resistance vs. Gate-source Voltage

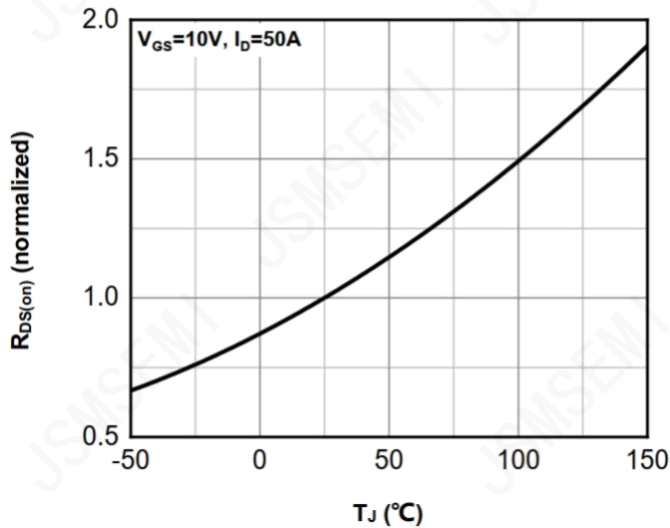

Figure 5: Normalized On-Resistance vs. Junction Temperature

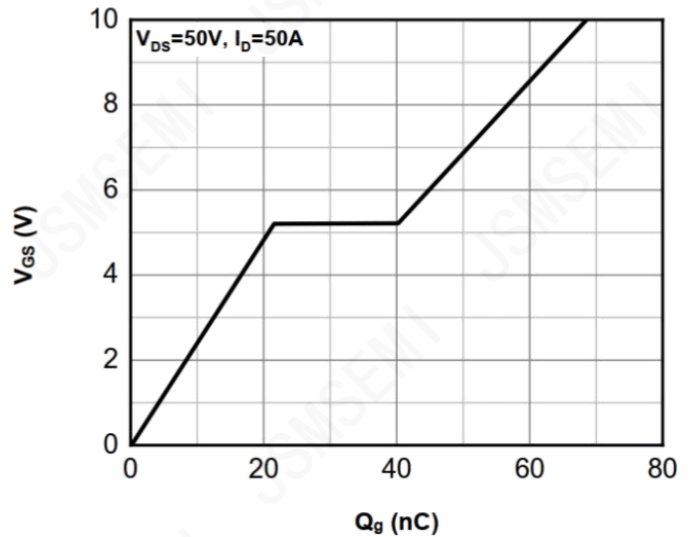

Figure 6: Typ. Gate Charge

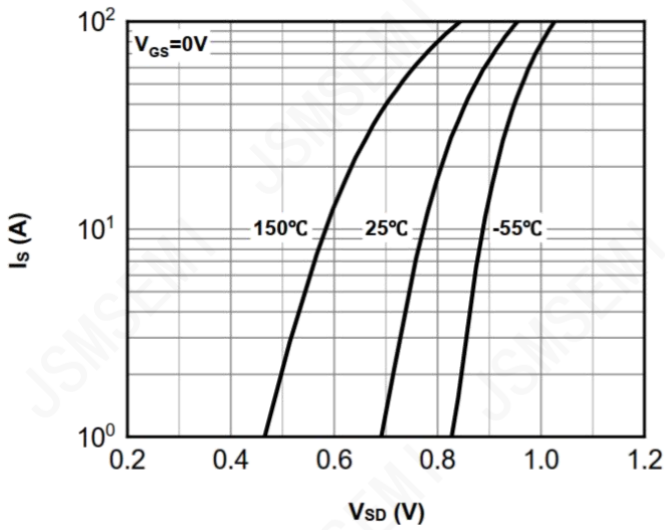

Figure 7: Typ. Forward Characteristics of Body Diode

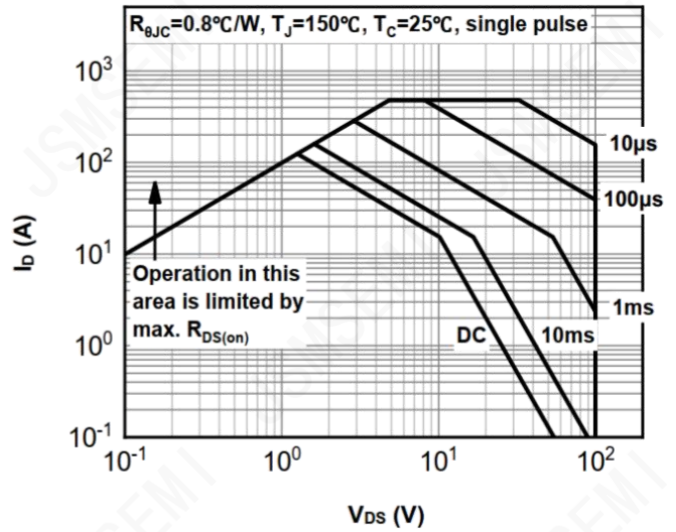

Figure 8: Safe Operating Area

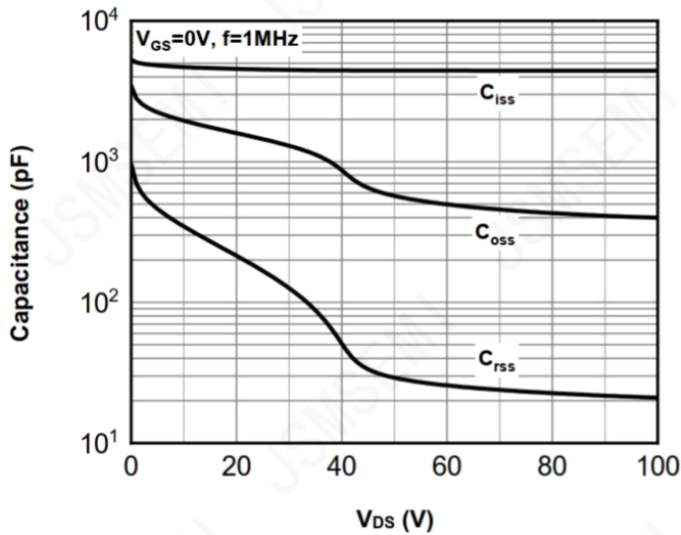

Figure 9: Typ. Capacitances

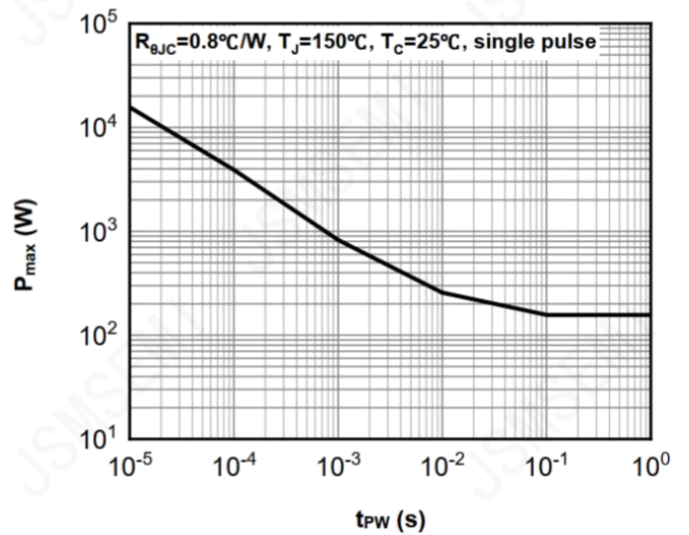

Figure 10: Single Pulse Maximum Power Dissipation

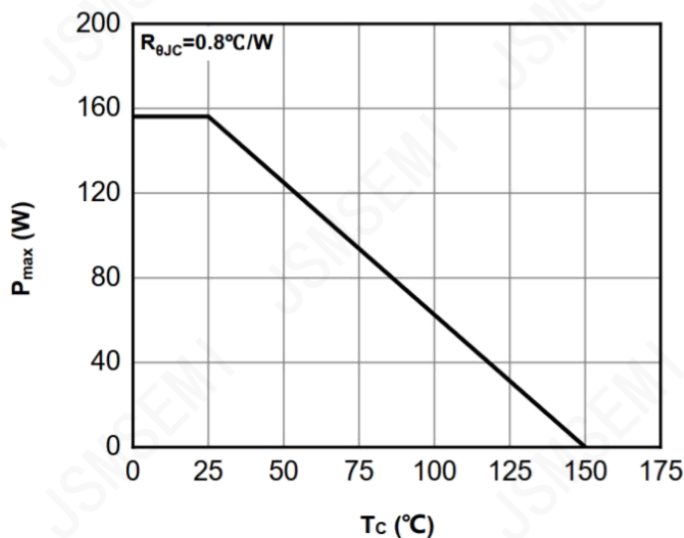

Figure 11: Max. Power Dissipation vs. Case Temperature

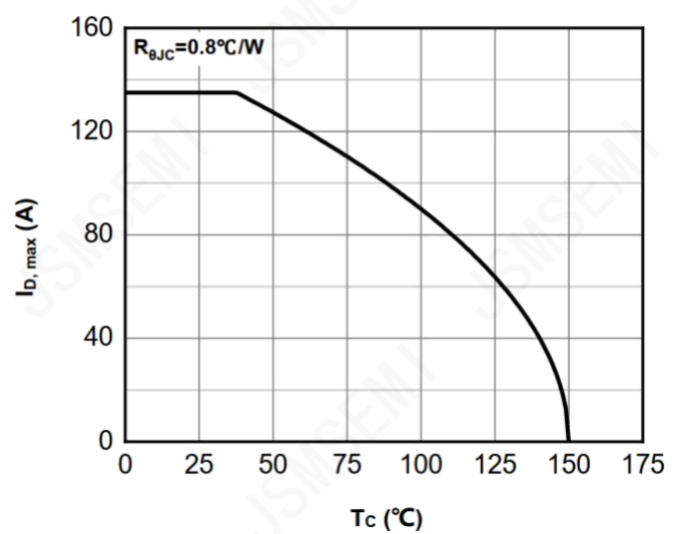

Figure 12: Max. Continuous Drain Current vs. Case Temperature

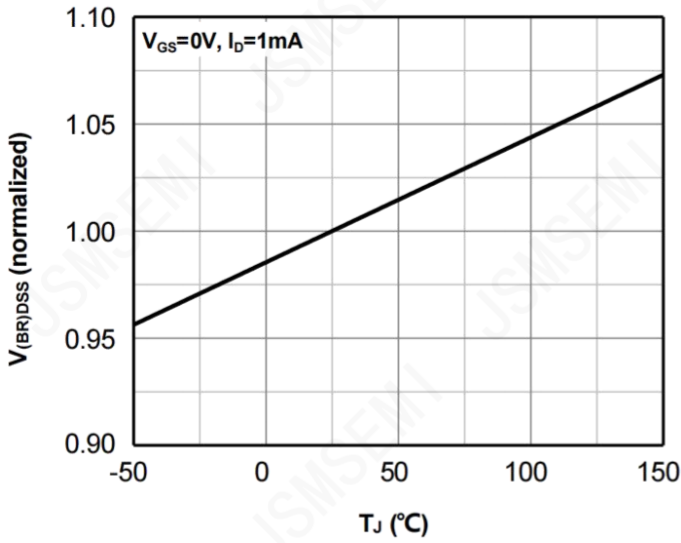

Figure 13: Normalized  $V_{(BR)DSS}$  vs. Junction Temperature

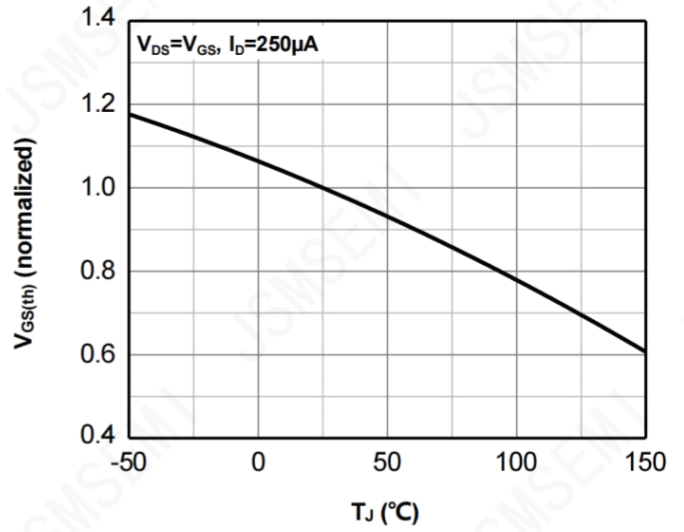

Figure 14: Normalized  $V_{GS(th)}$  vs. Junction Temperature

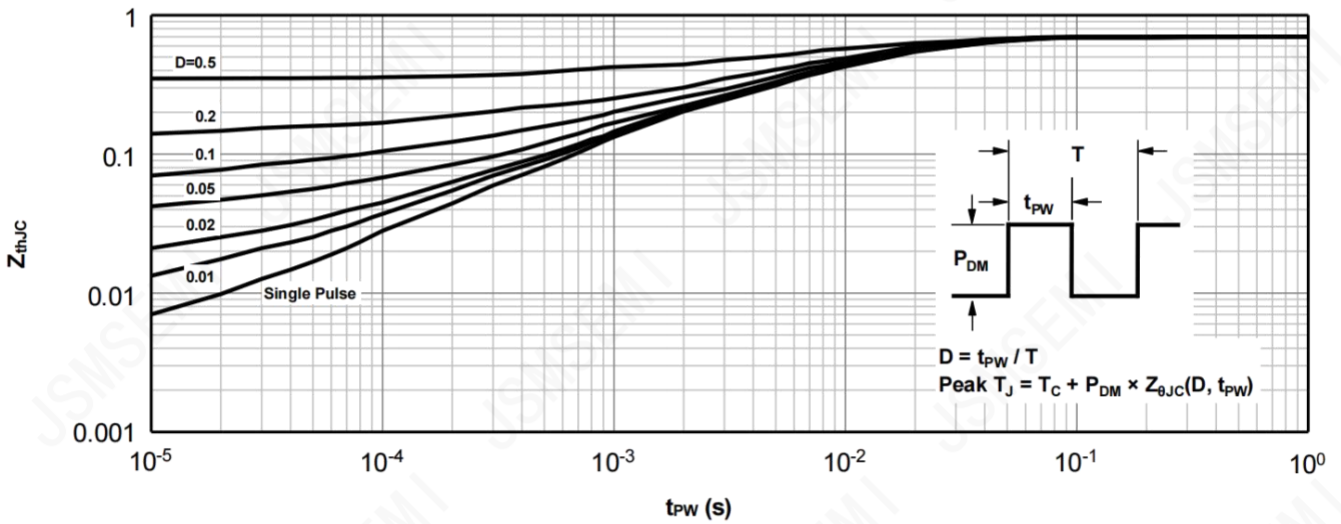
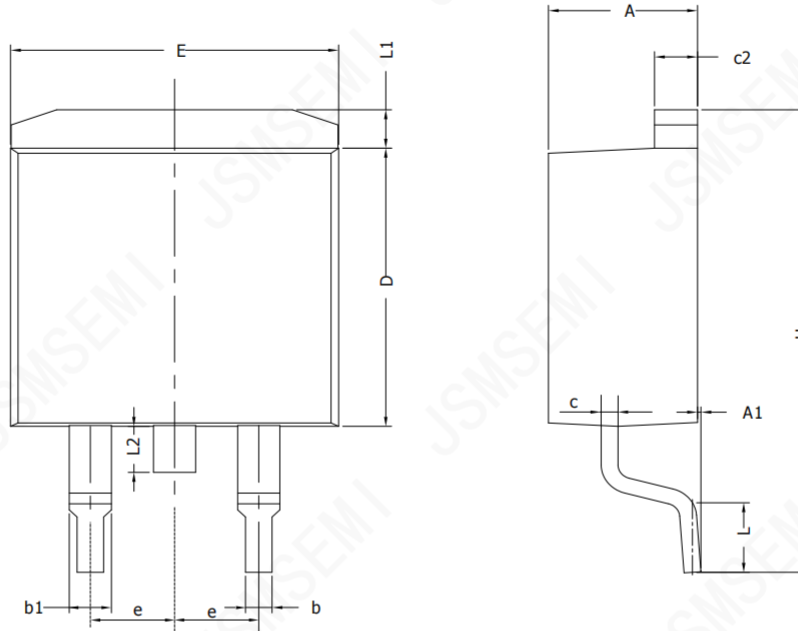

Figure 15: Normalized Transient Thermal Impedance Form Junction To Case

Package Information

TO-263-2



SYMBOL	MIN	NOM	MAX
A	4.30	4.57	4.72
A1	0	0.10	0.25
b	0.71	0.81	0.91
c	0.30	---	0.60
c2	1.17	1.27	1.37
D	8.50	---	9.35
E	9.80	---	10.45
e	2.54BSC		
H	14.70	---	15.75
L	2.00	2.30	2.74
L1	1.12	1.27	1.42
L2	---	---	1.75

## Revision History

Rev.	Change	Date
V1.0	Initial version	6/27/2021

## Important Notice

JSMSEMI Semiconductor (JSMSEMI) PRODUCTS ARE NEITHER DESIGNED NOR INTENDED FOR USE IN MILITARY AND/OR AEROSPACE, AUTOMOTIVE OR MEDICAL DEVICES OR SYSTEMS UNLESS THE SPECIFIC JSMSEMI PRODUCTS ARE SPECIFICALLY DESIGNATED BY JSMSEMI FOR SUCH USE. BUYERS ACKNOWLEDGE AND AGREE THAT ANY SUCH USE OF JSMSEMI PRODUCTS WHICH JSMSEMI HAS NOT DESIGNATED FOR USE IN MILITARY AND/OR AEROSPACE, AUTOMOTIVE OR MEDICAL DEVICES OR SYSTEMS IS SOLELY AT THE BUYER' S RISK.

JSMSEMI assumes no liability for application assistance or customer product design. Customers are responsible for their products and applications using JSMSEMI products.

Resale of JSMSEMI products or services with statements diferent from or beyond the parameters stated by JSMSEMI for that product or service voids all express and any implied warranties for the associated JSMSEMI product or s ervice. JSMSEMI is not responsible or liable for any such statements.

JSMSEMI All Rights Reserved. Information and data in this document are owned by JSMSEMI wholly and may not be edited, reproduced, or redistributed in any way without the express written consent from JSMSEMI.

Any and all information described or contained herein are subject to change without notice due to product/technology improvement, etc. When designing equipment, refer to the "Delivery Specification" for the JSMSEMI product that you intend to use.

For additional information please contact [Kevin@jsmsemi.com](mailto:Kevin@jsmsemi.com) or visit [www.jsmsemi.com](http://www.jsmsemi.com)