

規格承認書

PECIFICATION FOR APPROVAL

客戶

CUSTOMER : _____

項目

ITEM : 压电式无源蜂鸣器（外部驱动）

型號

TYPE : GPC9242YB-3V6000

描述

DESCRIPTION : 9.2 x 4.2 MM 3-30V 6000Hz 7000±30% ≤75DB PPO 材质 P=4.6MM

客戶料號

CUSTOMER NO. : C1121910

規格書號

SPECIFICATION NO.: _____

版本

EDITION NO. : V1.0

日期

DATE : _____

客戶承認

CUSTOMER CONFIRM AND SIGN

檢查 TESTED BY	審核 CHECKED BY	承認 APPROVED BY

東莞市贏海電子有限公司

DONGUAN INGHAI ELECTRONICS CO.,LTD

製作 ISSUED BY	審查 CHECKED BY	確認 APPROVED BY
刘波	刘承成	李海飞

地址：廣東省東莞市長安鎮上沙第五工業區新春科技園

電話 / TEL: 0769-83060958 傳真 / FAX: 0769-81608993

網址: HTTP://WWW.INGHAI.COM

DONGGUAN INGHAI ELECTRONICS CO.,LTD

Model NO: GPC9242YB-3V6000

DIMENSIONS Unit:mm

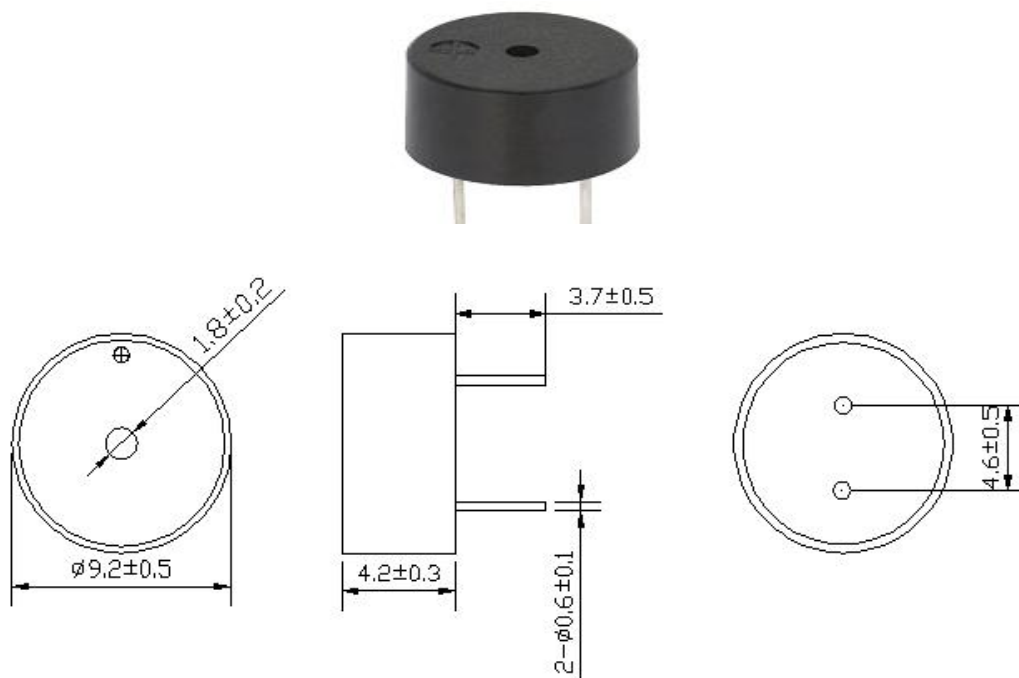

A: SPECIFICATIONS

Customer:	Part No:		
Product: Piezoelectric Buzzers	A&T Part No:		
Technical Terms			
Resonant Frequency (KHZ)	6.0 ± 0.5		
Rated Voltage (V _{P-P})	3		
Operating Voltage (V _{P-P})	1~30		
Max. Current Consumption at Rated Voltage (mA)	30		
Capacitance at 1000Hz (Pf)	7000 ± 30%		
Min. Sound Output at 10cm at Rated Voltage (dB)	≥ 70		
Operating Temperature (°C)	-20~+105		
Storage Temperature (°C)	-30~+105		
Housing Material	PBT(Black)		
Environmental Protection Regulation	RoHS		
Buzzer	Soldering Parameter		
Soldering process	Temp.(°C)	Time(Sec.)	Times

Inclusive Lead		Reflow soldering	230±10	above 170°C time 40~70	2
		Wave soldering	245±5	3~6	1~2
		Manual soldering	330±10	1~2	1~2
Lead Free		Reflow soldering	245±15	above 180°C time 40~70	3
	★	Wave soldering	260±5	4~8	2~3
	★	Manual soldering	350±10	1~3	2~3

Measuring condition

Part shall be measured under a condition (Temperature: 5~35°C, Humidity: 45%~85%R.H., Atmospheric pressure: 860 ~1060hPa) unless the standard condition (Temperature: 25±3°C, Humidity: 60±10%R.H. Atmospheric pressure: 860 ~1060hPa) is regulated to measure.

B: Acoustic Characteristics:

The oscillation frequency, current consumption and sound pressure are measured by the measuring instruments shown below

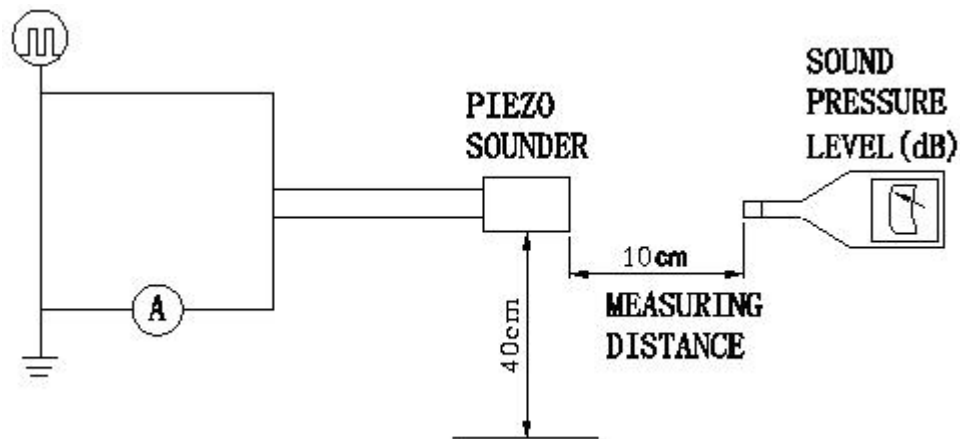

C: Typical Frequency Response Curve

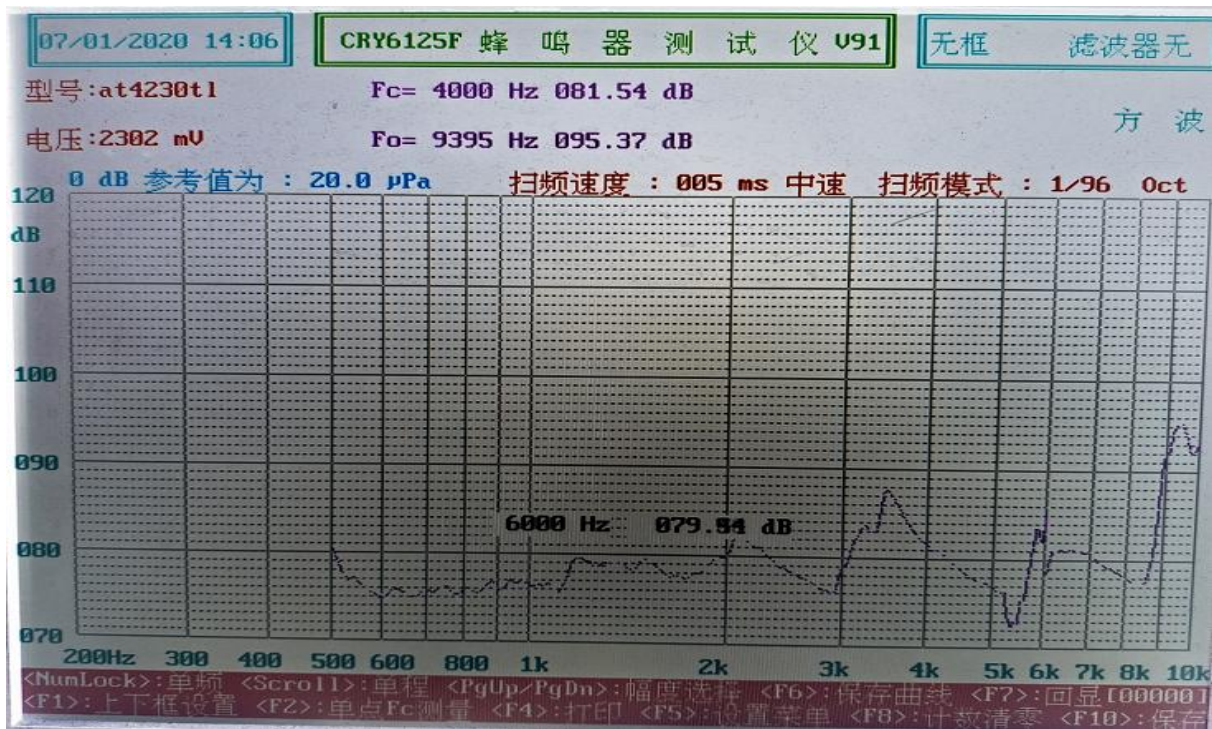

D: Reliability Test

After any following tests the part shall meet specifications without any degradation in appearance and performance except SPL. SPL shall not deviate more than -10 dB from the initial value

1. Ordinary Temperature Life Test

The part shall be subjected to 96 hours at $25 \pm 10^\circ\text{C}$. Input rated voltage Resonant frequency, 1/2 duty Square wave.

2. High Temperature Test

The part shall be capable of with standing a storage temperature of $+80^\circ\text{C}$ for 96 hours.

3. Low Temperature Test

The part shall be capable of with standing a storage temperature of -30°C for 96 hours.

4. Humidity Test

Temperature: $+40^\circ\text{C} \pm 3^\circ\text{C}$ Relative Humidity: 90%~95% Duration: 48 hours and expose to room temperature for 6 hours

5. Temperature Shock Test

Temperature: 70°C /1hour \rightarrow 25°C /3hours \rightarrow -30°C /1hour \rightarrow 25°C /3hours (1cycle)
Total cycle: 10 cycles

6. Drop Test

Standard Packaging From 120mm(Drop on hard wood or board of 5cm thick, three sides, six plain.)

7. Vibration Test

Vibration: 1000cycles /min. Amplitude: 1.5mm, Duration: 1 hour in each 3 axes

Note:

As this product is not protected from foreign material entering, please make sure that any foreign materials (e.g. magnetic powder, washing solvent, flux, corrosive gas) do not enter this product in your production processes. The functional degradation (e.g. SPL down) may occur if foreign material enter it.