

## 12V dual full H-bridge driver

### Chip description

GC3909S is dual channel 12V DC motor driver chip, which provides integrated motor drive solutions for cameras, consumer products, toys and other low-voltage or battery powered motion control applications. The chip is usually used to drive two DC motors or one stepper motor.

GC3909S can work in 3.8 ~ 14V supply voltage, each channel can provide up to 1.5A continuous output current or 2.5A peak current, power consumption is less than 1uA in sleep mode.

GC3909S has PWM (IN/IN) input interface, compatible with industry standard devices, and has over temperature protection, under voltage protection, short circuit protection, over current protection and other functions. GC3909S has built-in LDO, no logic power supply is needed, and the input is compatible with 3.3V and 5V.

### Chip features

- H-bridge motor driver
  - The power supply voltage is 3.8 ~ 14V
  - Low on impedance (HS + LS) 350m Ω
- 1.5A continuous drive output current
- PWM (IN1/ IN2) input mode
- Compatible with 3.3V, 5V logic input
- Built in over temperature protection
- short circuit protection,
- Low current sleep mode (nA level, IN1= IN2 = 0)

### Chip application

- stepper motor driver
- Digital single lens reflex (DSLR) lens
- White goods
- Robot technology
- Sharing bicycle lock
- Water meter switch
- Medical equipment

Product	Package	Description
GC3909S	SSOP10L	4.9*3.9, e=1.0

### Packaging Introduction

Per Tray	Per Box	Per Case
4K	8K	64K

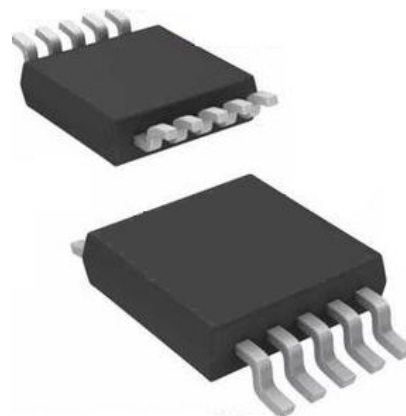

## Pin Map

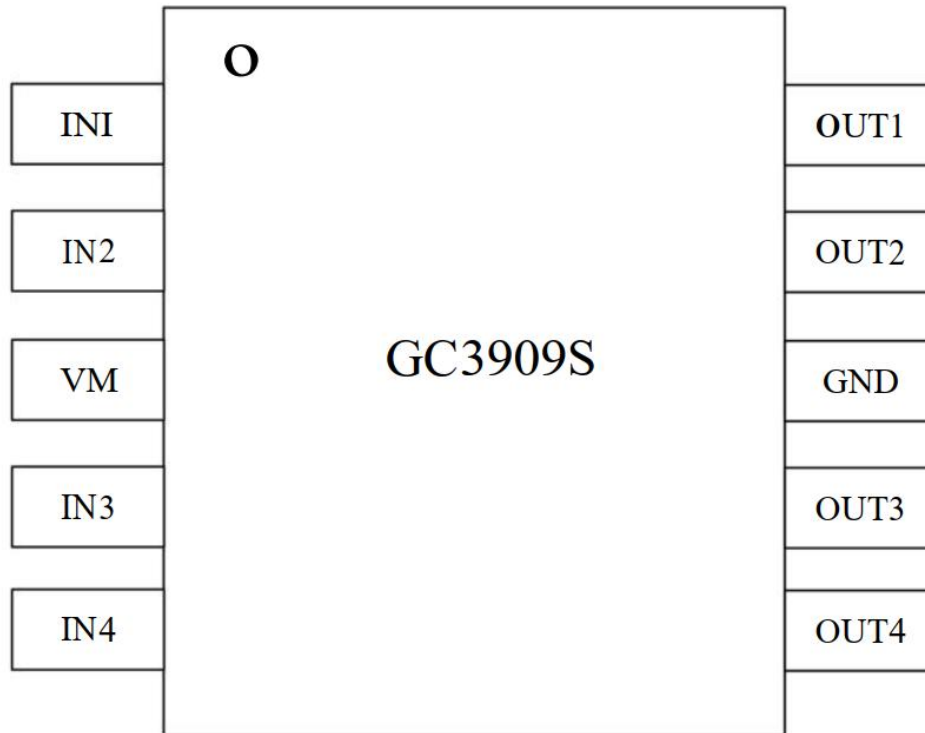

## Pin description

Pin No.	Pin Name	I/O	Pin Function
SSOP10L			
1	IN1	I	Logic input 1
2	IN2	I	Logic input 2
3	VM	power	Power Supply
4	IN3	I	Logic input 3
5	IN4	I	Logic input 4
6	OUT4	O	H-bridge output 4
7	OUT3	O	H-bridge output 3
8	GND	ground	ground
9	OUT2	O	H-bridge output 2
10	OUT1	O	H-bridge output 1

Internal block diagram

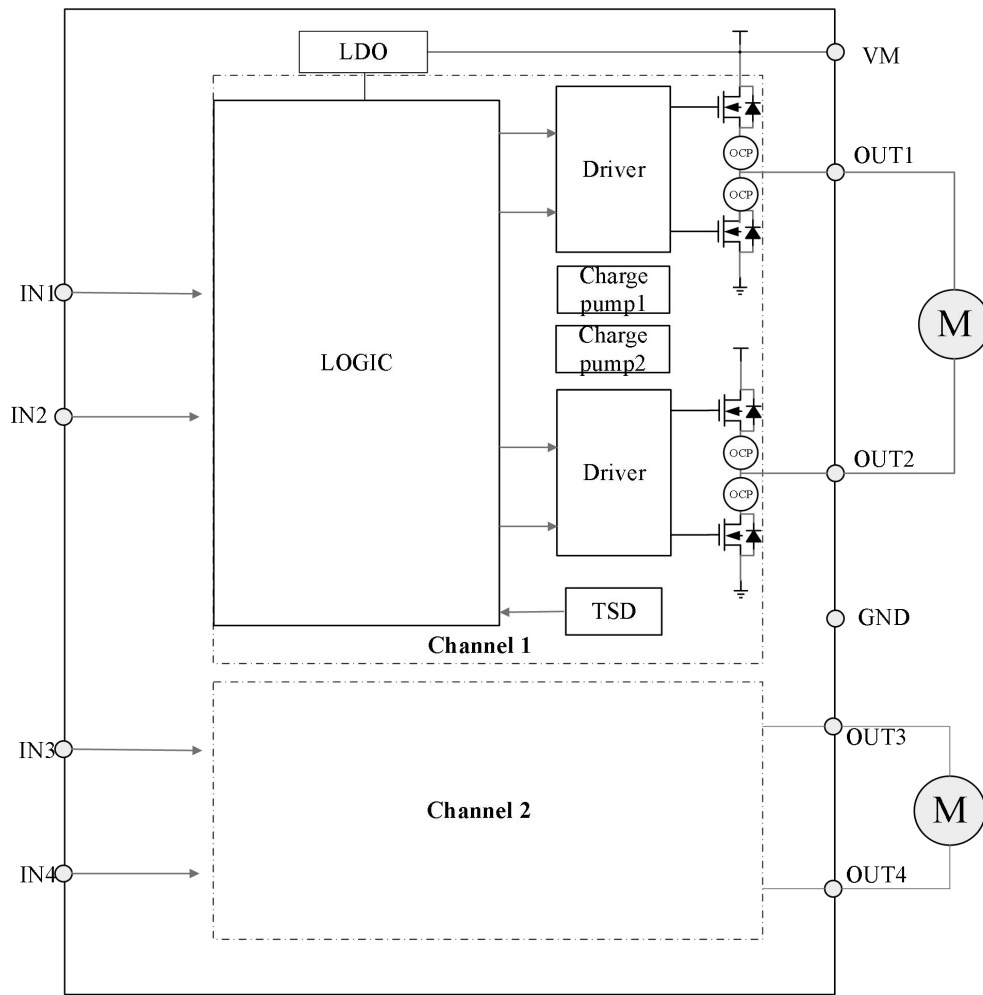

Figure 1 : GC3909S internal block diagram

## Limit parameter

(t = 25 °C when there is no other special indication)

Parameters	Symbol	Parameter range	Company
Load voltage	VM	0~17	V
Control input voltage range	INx	-0.5~7	V
Long time constant current	Ion	±1.5	A
Driving peak current	I <sub>max</sub>	±2.5	A
Junction temperature	T <sub>jmax</sub>	-40~150	°C
Storage temperature	T <sub>stg</sub>	-60~150	°C
Electrostatic protection (body mode)	ESD	±5000	V

## Electrical parameters

(t = 25 °C, VM = 12V when there is no other special indication)

Parameters	Symbol	Test conditions	minimum value	Typical value	Maximum	Company
Load power supply	VM		3.8		14	V
Output current	IO <sub>UT</sub>	Per channel	-1.5		1.5	A
External PWM frequency	f <sub>PWM</sub>		0		500	kHZ
working temperature	T <sub>a</sub>		-40		100	°C

(no other description, t = 25 °C, VM = 12V)

Parameters	Symbol	Test conditions	minimum value	Typical value	Maximum	Company
VM working current 1	I <sub>VM</sub>	No PWM, no load		1.5	3.0	mA
VM working current 2	I <sub>VMQ</sub>	INX = 0 power saving mode		0.01	1	uA
<b>Output H-bridge parameters</b>						
Upper side + lower side bridge on resistance	R <sub>dsON1</sub>	I <sub>o</sub> =500mA;T=25°		350	450	mΩ
	R <sub>dsON2</sub>	I <sub>o</sub> =500mA;T=125°		530	700	mΩ
Off state leakage current	I <sub>OFF</sub>	V <sub>out</sub> =0V	-10		10	uA

<b>Logic input pin (in1, IN2)</b>						
Logic low input voltage	VIL	INx		1.28		V
Logic high input voltage	VIH	INx		1.58		V
Input logic hysteresis	VHY	INx		300		mV
Logic low input current	IIL	Vinx=0	-5		5	uA
Logic high input current	IIH	Vinx = 3.3V, INX pin		30		uA
Pull down resistance	Rpd	INx		108		kΩ
<b>protection circuit</b>						
Over temperature protection	TSD	temperature rise	155	169	180	°C
Over temperature protection hysteresis	ΔTSD			18		°C
Under voltage protection	VUVLO	Power VM		3.64		V
Under voltage protection	ΔVUVLO	Power VM		0.17		V
Over current protection	IOCP	Upper arm bridge		3.0		A
		Lower arm bridge		3.0		A
Over current protection hysteresis	T <sub>DEG</sub>	Delay time of over current protection		2.3		us
Over current protection recovery time	Tretry	Over current protection recovery time		1.5		ms

**Time series parameters and curves**

TA = 25°C, VM = 5 V, RL = 20 Ω

parameter	condition	Range		Company
		minimum	maximum	
T1	Start time from sleep to work		10	us
T2	Turn off time		220	ns
T3	High input to high output delay		100	ns
T4	Low input to low output delay		100	ns
T5	Output rising edge	10	188	ns
T6	Output falling edge	10	188	ns

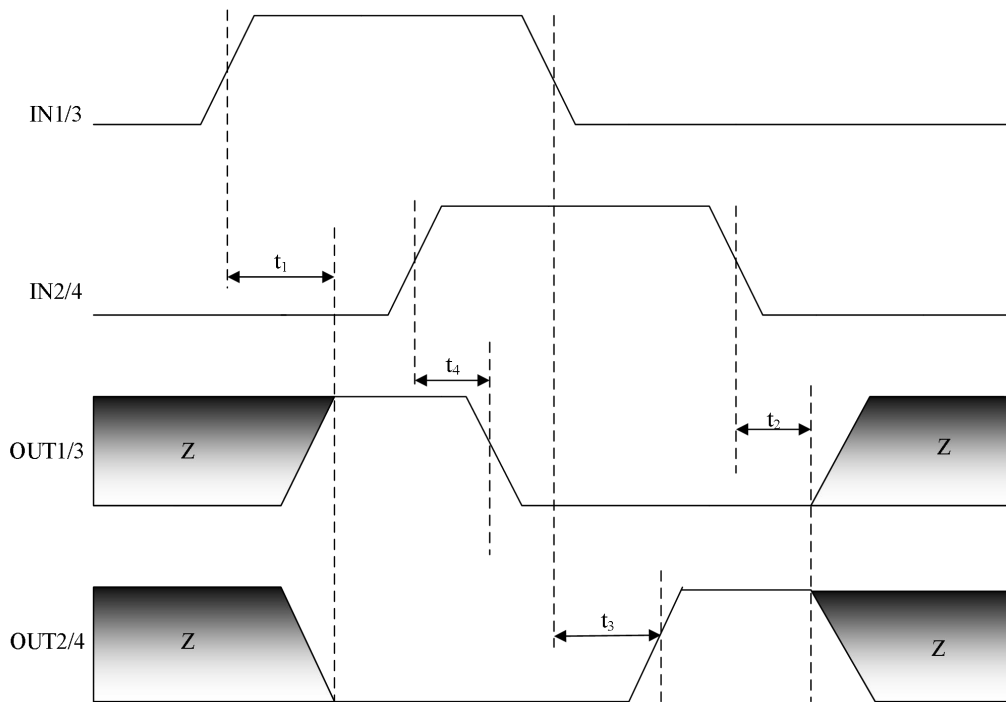

Figure 2 GC3909S time sequence 1

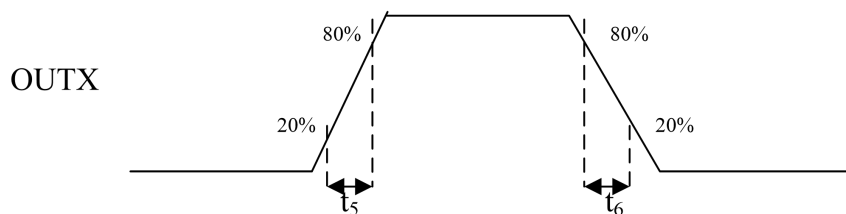

Figure 3 GC3909S time sequence2

## Function description

### H-bridge Control

GC3909 is controlled by PWM input interface, also known as IN/IN input mode. Its control truth table is as follows:

#### Drive DC motor:

IN1/3	IN2/4	OUT1/3	OUT2/4	function
0	0	Z	Z	Standby sleep mode
0	1	L	H	reverse
1	0	H	L	Positive
1	1	L	L	brake

### Driving stepper motor:

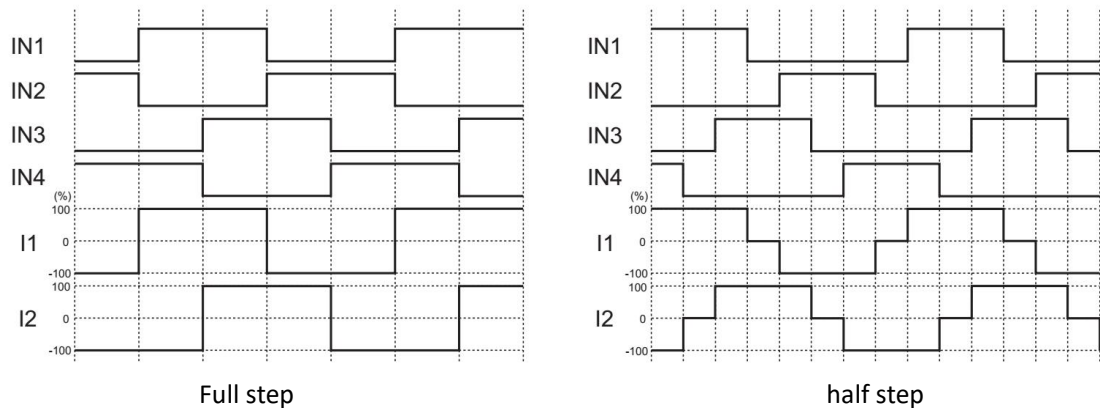

### sleep mode

When IN1 and IN2 are low ( $< 0.85V$ ) at the same time, channel 1 enters sleep mode; when IN3 and IN4 are low ( $< 0.85V$ ) at the same time, channel 2 enters sleep mode; in sleep mode, channel current is less than  $1\mu A$ .

It takes about  $7\mu s$  to start the internal reference from sleep mode to normal operation. When you need to use the logic of  $IN1 = IN2 = 0$  or  $IN3 = IN4 = 0$  to do PWM regulation, pay attention to set the input low level between  $0.9 \sim 1.2V$ , so as to avoid triggering the sleep mode.

### Input pin

INX input pin has  $100k\Omega$  pull-down resistance inside, default setting low level input.

### protection circuit

#### Over temperature protection

When the junction temperature of the chip exceeds  $169^\circ C$ , the over temperature protection circuit is activated and all the output transistors are turned off. When the temperature drops by a hysteresis temperature of  $18^\circ C$  and reaches  $157^\circ C$ , all the output transistors will return to work; because the over temperature protection is only activated when the junction temperature of the chip exceeds the set value, it can not guarantee that the product will not be damaged with this circuit, so the chip is equipped with short-circuit over-current protection.

**over current protection( OCP)**

The chip has built-in over-current protection circuit for each drive tube of H-bridge, when detecting that the current of any drive tube exceeds the IOCP ,and also the delay time exceeds tdeg (2.3us), all the drive tubes will be closed; after a retry time (1.5ms), the drive tubes will automatically try to return to normal operation, if the abnormal current continues to exist, the above-mentioned turn off recovery turn off process will be repeated.

The over-current protection is generally aimed at the protection under the abnormal state to prevent the chip from burning. For example, when the upper side bridge of out1 is on, if out1 abnormally contacts GND, or when the lower side bridge of out2 is on, out2 abnormally shortens to the power supply.This kind of protection is also called short power supply and short ground protection.

**Working mode**

GC3909 enters sleep mode when INX is all low. In sleep mode, all H-bridges are turned off . Most circuits of the chip circuit are turned off and enter power saving mode.When INX is not all low at the same time, it will automatically return to normal operation. When the over temperature protection detects failure, it will also close the H-bridge.

pattern	condition	H bridge
work	INX is not 0 at the same time	work
Sleep mode	INx=0	Turn off
Failure detection	INX = x, over temperature, under voltage or over current	Turn off

Typical application circuit

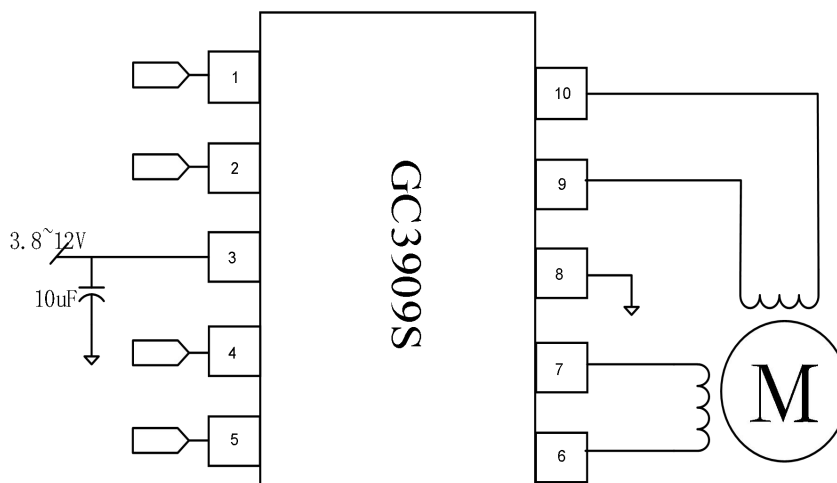

Figure 4 GC3909S drives a stepper motor

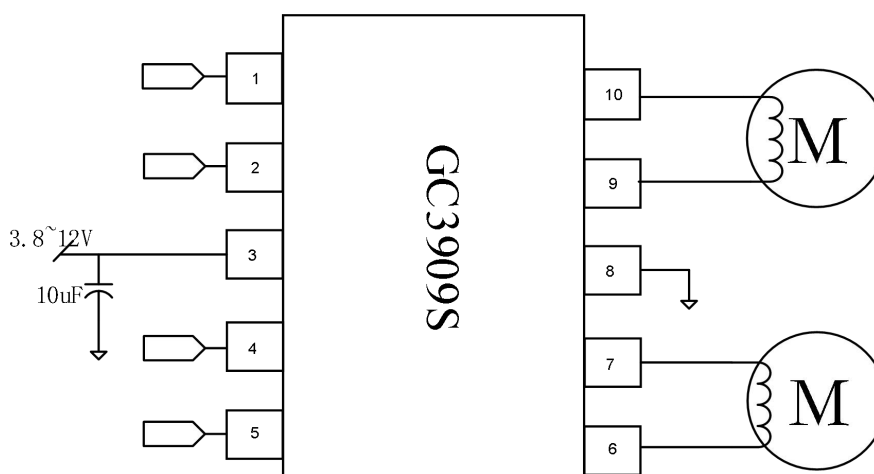
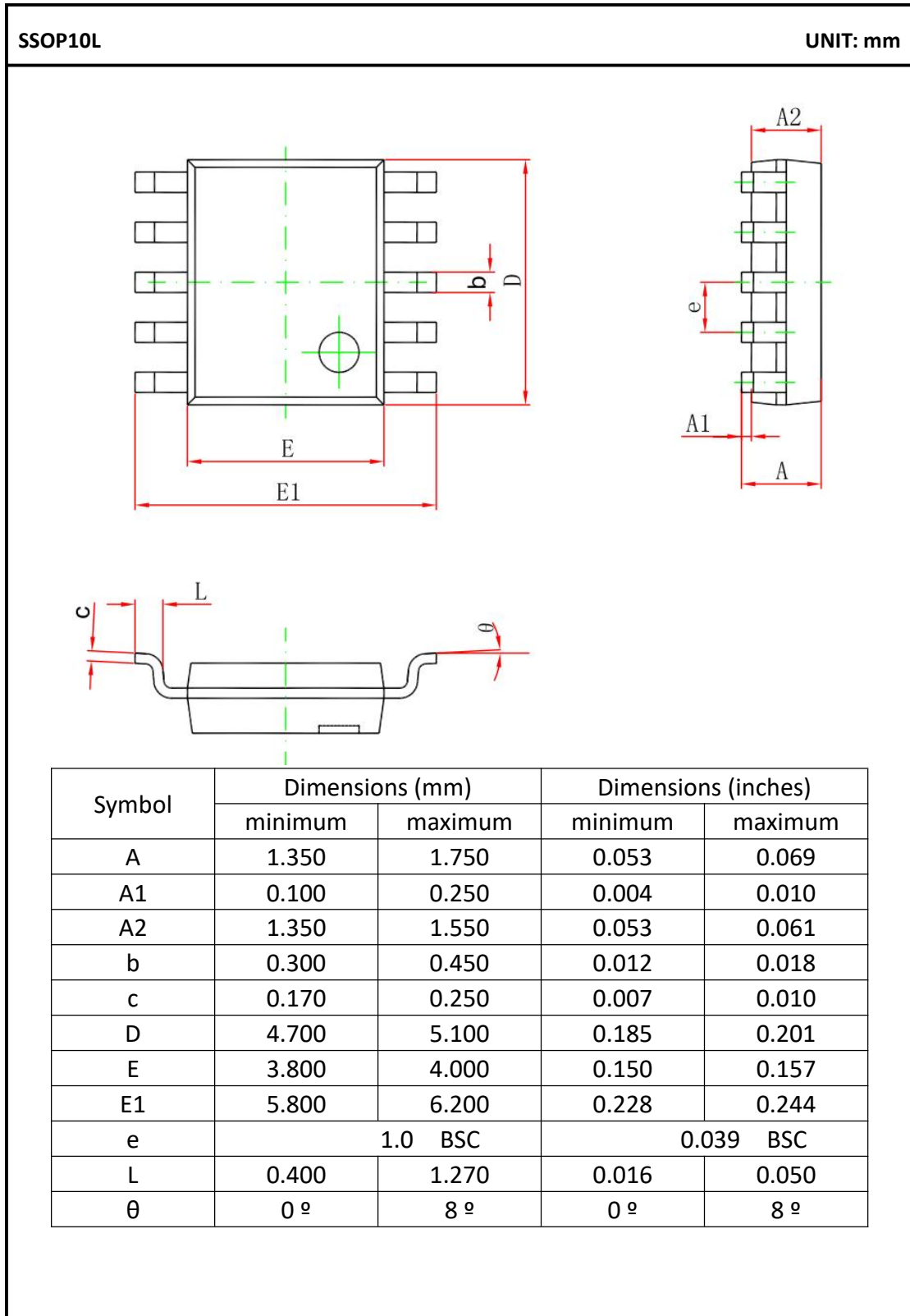
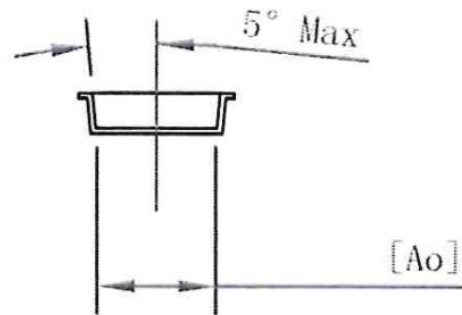
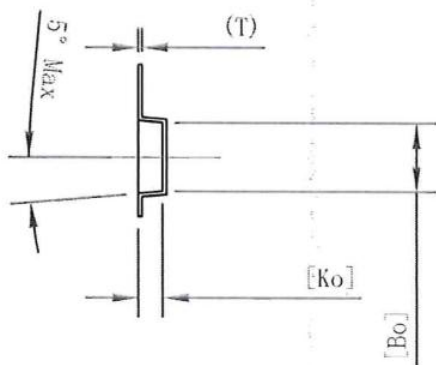
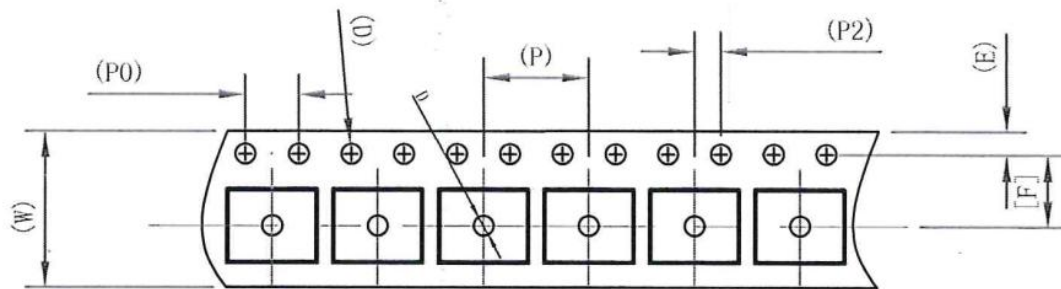

Figure 5 GC3909S drives two DC motors

- The absolute parameters of the chip should not be exceeded in any environment;
- The bypass capacitor of VM, especially the ceramic capacitor, should be connected as close as possible to the VM pin of the chip
- When the supply voltage or current of VM is high, the bypass capacitance of VM increases to more than 10uF.

**Package outline**

**Packaging Introduction for GC3909S**



ITEM	W	A0	A1	B0	B1	K0	K1
DIM	12.0	6.55	0.00	5.40	0.00	1.90	0.00
TOLE	±0.10	±0.10	±0.10	±0.10	±0.10	±0.10	±0.10
E	F	P	P0	P2	D0	D1	T
1.75	5.50	8.0	4.0	2.0	1.50	1.50	0.25
±0.10	±0.10	±0.10	±0.10	±0.10	+0.10 -0.00	+0.10 -0.00	±0.05

## Description of Lot Code

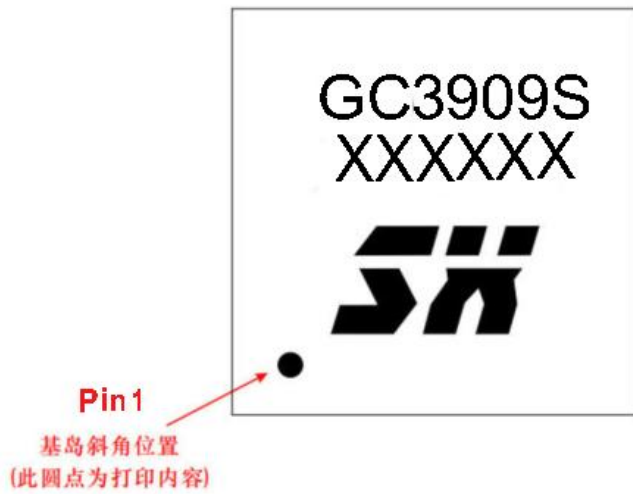

Printing instructions:

- 1.The first line GC3909S represents the product model
- 2.The second line represents the traceability code

## Release Notes

Revision	Description
1.0	Initial version;
1.1	Corrected ambiguity in some descriptions ;
1.2	Added packaging instructions;
1.3	updating lvm parameter;