

F9J GCB;

8C BCB
G7 5@FC A
H-GDF B H

E A G L L L ! L L L ! L L ! 8 ! F 5 ! L L L ! L L

FE A Q \$) & \$ % L L ! 8 ! F 5 ' G < C K B L

Bc C : DC G H C B G
! \$ & * Z ! \$) & Z ! \$ + , Z ! % \$ (
f D 9 F C K L

D5 7 ? 5 : B ; C D H C B
! H F . H 5 D 9 7 ' F 9 9 @ D 5 7 ? 5 ; B ;
f ! \$ & * / ! \$) & K # : B C ' C D H C B C
f ! \$ & * / ! \$) & K # : ! D 7 (L
f ! \$ & * K # : ! D 7 , L

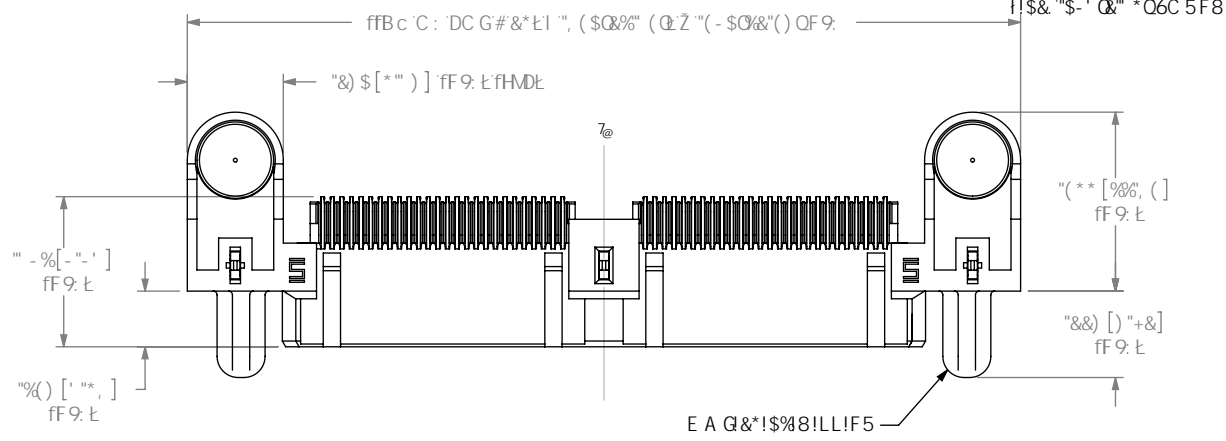

C D H C B
! ? . 7 5 D H C B D 5 8 f l G 9 ? ! ,) \$! *) \$ L
! D 7 (. : D C K 9 F ' D B G
..... f G 9 9 : = " & Z < 9 9 H ' L
..... f B C H 5 J 5 6 6 @ K # : ! % \$ (D C G L
! D 7 , . : D C K 9 F ' D B G
..... f G 9 9 : = " ' Z < 9 9 H ' L
..... f B C H 5 J 5 6 6 @ K # : ! % \$ (D C G L
! ! A : D . A 9 H 5 @ : ! - 8 9 D C G H
..... f B C H 5 J 5 6 6 @ K # : ! \$ &
..... @ 5 8 G H M D L
! F 5 . F = < H 5 B ; @

F C K G D 9 7 = 7 5 H C B
! 8 : 8 C 1 6 @ f l G 9 E A G L L L ! \$ % 8 ! L L ! F 5 L

D @ H B : ' G D 9 7 = 7 5 H C B
! G @ @ < H G 9 @ 7 H J 9 : C @ B
..... f l G 9 H % A () ! \$ % G @ H % A (* ! \$ % G @ K H & , ! L L ! H
..... A ! % & ! L L ! @ H % G * - ! L L ! G @ H % F ' + ! L L ! H
! G : G 9 @ 7 H J 9 : C @ B
..... f l G 9 H % A () ! \$ % G @ H % A (* ! \$ % G @ K H & , ! L L ! H
..... A ! % & ! L L ! @ H % G * - ! L L ! G @ H % F ' + ! L L ! H

f 1 B C H F 9 @ 5 G 8 : C F D F C 8 I 7 H C B

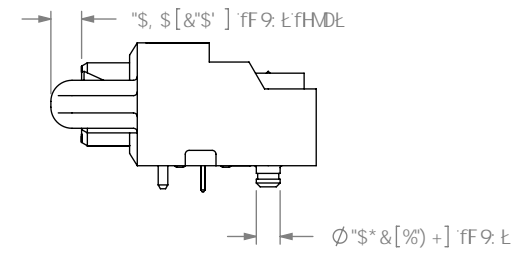
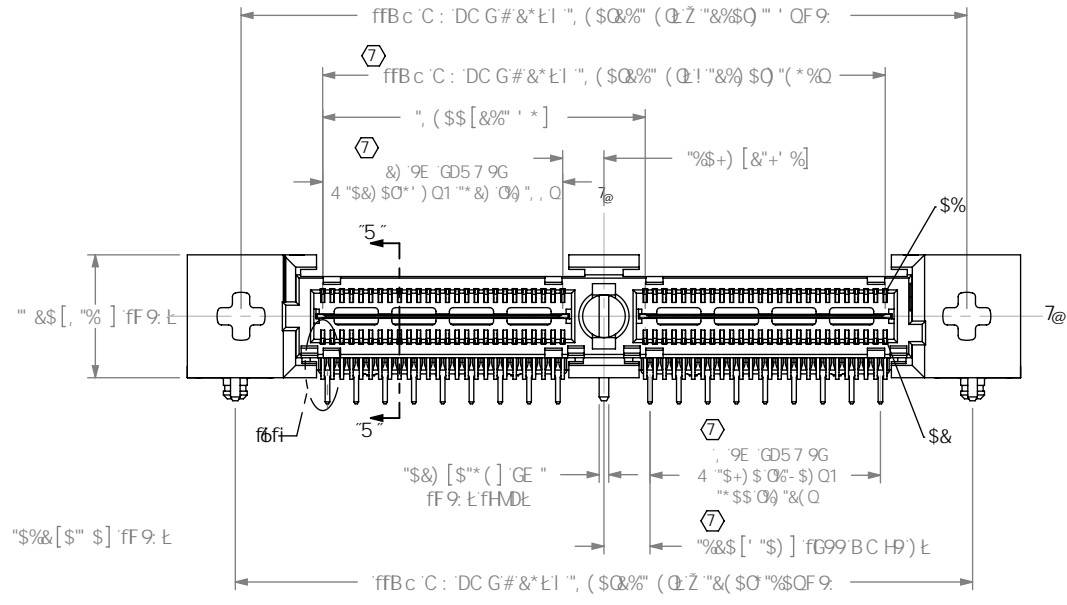

7 @
" \$ % [\$ " &]

8 9 H 5 @ f b f i
G 7 5 @ * : %

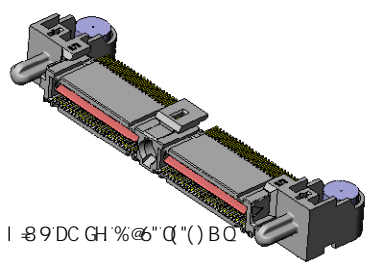

BC H G

% 7 F 9 D F 9 G 9 B H G 5 7 F # 7 5 @ 8 A 9 B G C B "
& " 6 l F F 5 @ C K 5 B 7 9 . " \$ \$ % \$ Q " \$ \$ & O 5 L "
! " A - B A I A ' D I G < C I H : C F 7 9 . G = B 5 @ " ' @ z Q " & & B O
... G < 9 @ # , F C I B 8 Z D C K 9 F ' D B 2 7 C I B H F K 9 = < H 5 B 8 ' A 9 H 5 @ : ! - 8 9 D C G H ' % @ " Q ") B Q
(" D 5 F H G C ' 6 9 D 5 7 ? 5 : 9 8 ' B ' F 5 M G 5 G G 5 B 8 5 F 8 "
) " 8 C 9 G B C H 5 D D @ M H C ' % 6 5 B ? "

I B @ G G C H 9 F K @ 9 ' G D 9 7 = 9 8 Z
8 A 9 B G C B G 5 F 9 ' B ' B 7 < 9 G "
H C @ F 5 B 7 9 G 5 F 9 .
8 9 7 A 5 @ 5 B : @ G
" L L ± \$ * O O & "
" L L L ± \$ \$) O % O
" L L L L ± \$ \$ & O S) % O

D F C D F 9 H 5 F M B C H 9
H : 6 8 C 7 1 A 9 8 H 7 C B H 6 B G B : C F A 5 H C B
7 C B : 8 9 8 H 6 @ 5 8 8 D F C D F 9 H 5 F M C
G 5 A H 7 2 B 7 " 5 B 8 G : 5 @ B C H 6 9 F 9 D F C 8 I 7 9 8
C F H 5 B G 9 F 9 8 H C C H 9 F B C 7 1 A 9 8 H G C F
8 6 7 @ C 9 8 H C C H 9 F G C F I 9 8 : C F 5 B M
D I F D C 9 C H 9 F H 5 B H 5 H K < 7 < H K 5 G
C 6 5 8 9 8 K # C I H H 9 9 L D F 9 G 9 8 K F # 9 8
7 C B 9 8 H C : G 5 A H 7 2 B 7 "

A 5 H F 5 @ 8 C ' B C H G 7 5 @ 9 8 F 5 K B : G 9 9 H G 7 5 @ 9 . % &
- B G @ H C F . @ D 2 7 C @ F ' 6 @ 5 7 ?

7 C B H 5 7 H 2 D C K 9 F ' D B 2 / : F C I B 8 D @ 5 B 9 . D < C G 6 F C B M 9
7 C I B H F K 9 = < H 5 6 5 G G
A 9 H 5 @ : ! - 8 9 D C G H ' N B 7

: . P 8 K : P A @ 7 P A ? H P E A G L L L L L L L L L L I 8 I 5 I L L L L I I A ? H G 8 B F K

& \$ D 5 F ? 9 5 G H 6 @ 8 2 B 9 K ' 5 @ 5 B M - B (+) \$
D < C B 9 ; % & - ((! * +) : ; , - . / :) \$ (+
Y I A U] . } z . 4 G 5 A H 7 ' W c a W e X Y .) ' & &

8 9 7 F @ H C B .
" * * ") a @ 8 I 5 @ F C K ' F = < H 5 B ; @ 9 D @ ; ' 5 G 9 A 6 @ M

8 K : " B C "
E A G L L L ! L L L ! L L ! 8 ! F 5 ! L L L ! L L

6 M ? B C K @ 9 B , # &) # & \$ \$ * G < 9 9 H % C : (

F9J €€ B'';

∇
"\$+, +[&'\$\$"
fA 95G F98: FCA 'HdGC: 'H5 €€

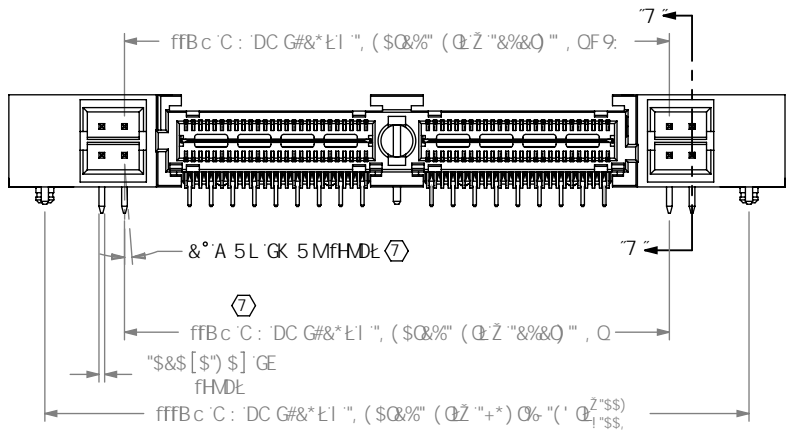
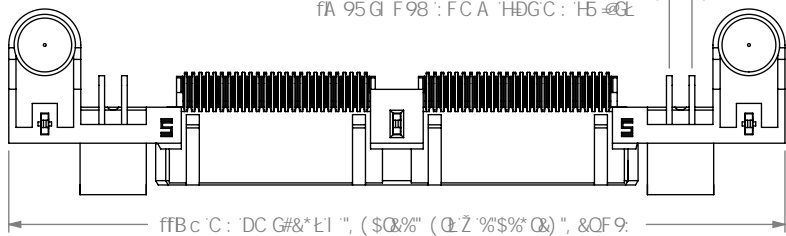

: ≡ "&
fE A G(\$) &LL!LL!8!F5!D7 ('G<C K BŁ
fG5A 95G: ≡ "'&Z8≡: 9F 9B H5GG<C K BŁ

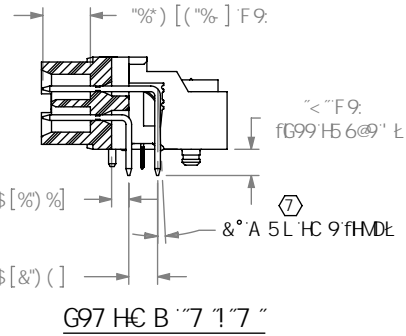

G97 H€ B "7 "1 "7 "

H9FA -B5@&
fG99 H5 6@' Ł

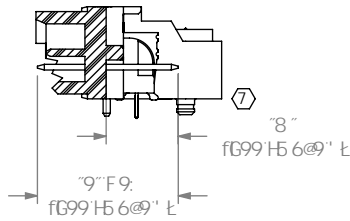
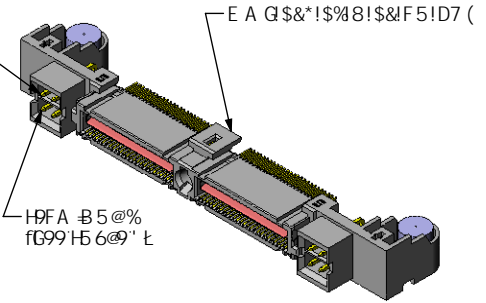

B!DFC 7 9GG(

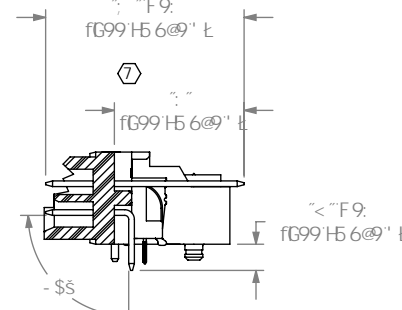

B!DFC 7 9GG)

H5 6@'							
@58 GHM@	H9FA -B5@%	H9FA -B5@&	"8"	"9"	"1"	"2"	"3"
!\$%	H%G*-!\$%LL	H%G*-!\$&LL	"&)"	"(,"	"(,"	"(,"	"(,"
!\$&	H%G*-!\$!LL	H%G*-!\$(!LL	"&,%	"&,\$	"(,%	"&,\$	"&,\$

: ≡ ""
fE A G(\$) &LL!LL!8!F5!D7, 'G<C K BŁ
fG5A 95G: ≡ "'&Z8≡: 9F 9B H5GG<C K BŁ

∇
fI '9E I 5@GD57 9G5H"\$+, +Q"\$\$\$\$Q
fA 95G F98 '5HHdGC: 'H5 €€

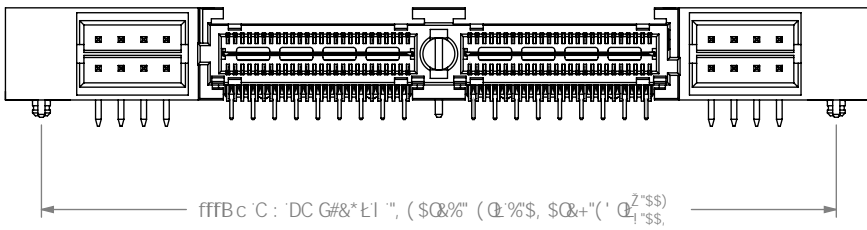
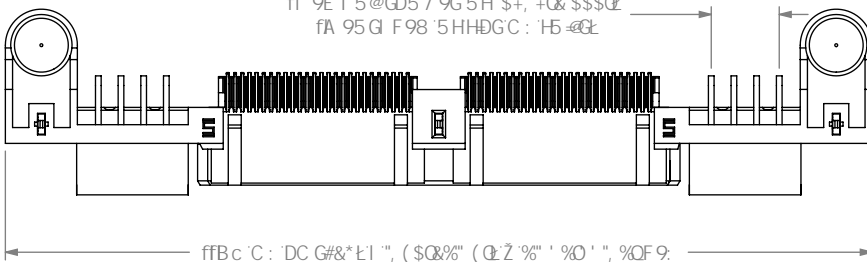

H9FA -B5@&
fG99 H5 6@' Ł

H9FA -B5@%
fG99 H5 6@' Ł

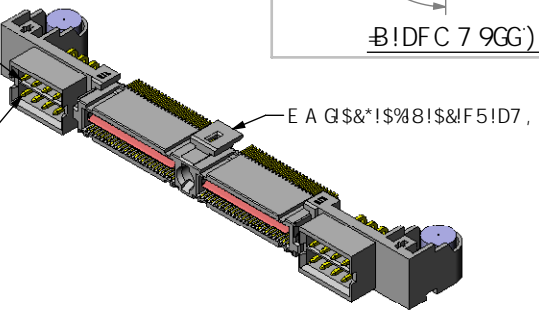

DFC.DF-9H5 FMBCH9
H: 6BC 71A 98H7C B15 BG B: CFA 5HC B
7C B: 89H5 95B8 DFC DF 945 F4M C
GSA H97 2 87 5B8 G-5MBCH 9F90FC 81 7 98
CF HF5BG 9F98 HC CH: 9F 8C 71A 98HC F
8 47 @C 98 HC CH: 9FGCF I 98: CF 5BM
DI DFC 09 CH: 9F H: 5B H: 5HK <7 < HK 5G
C 615 B 98 K H: C I H: 9 9L DF 9098 K F H98
7C B 98HC: GSA H97 2 87 "

8C 'BCH G7 5@ 8F5K B:

G: 99HG7 5@ 9%)%



)&\$ D5F? 95GH6@ 8ZB9K '5@5BM-B (+%) \$
D<C B9; %&L-((!'+.....SL; %&L-(,)\$ (+
YIA UJ; ĩž: 4 GSA H97 'Wca W€XY.)')&&

89G7 F@HC B:
"*') a a '81 5@FCK F≡ <H5B; @D@; '5G9A 6@M

8K: ""BC"
E A QLLL!LL!LL!8!F5!LLL!LL

6M ?BCK @B9B, #&) #&\$ \$* G<99H""C: (

F9J €€ B'';

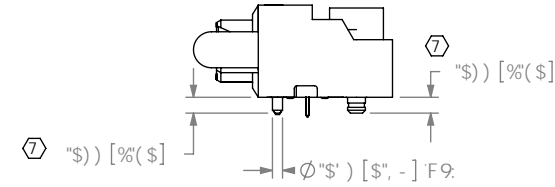
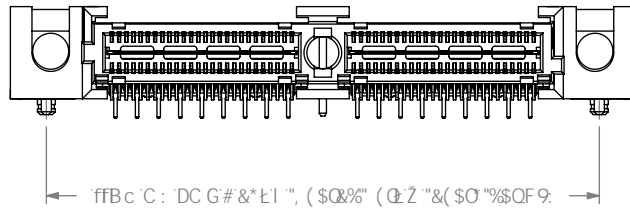
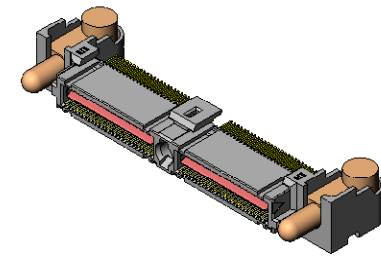
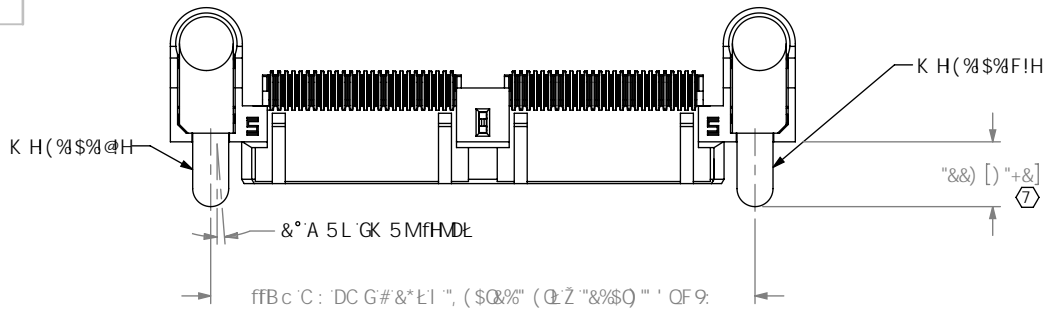

FE A G\$) &\$%LL!8!F5!A ; D'G<C K BŁ
fG5A 9'5G: ÷ "%ž8 ÷: 9F 9BH5G<C K BŁ
BCHF9@5G98 : CF DFC 8I 7HC B

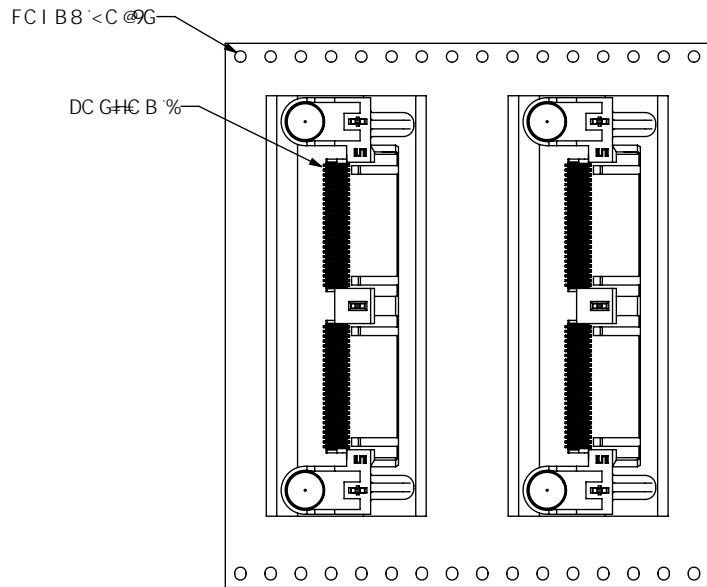

D57?5; B: 'J 9K
!F. H5D9/ F99@C DHC B
FE A G\$) &\$%LL!8!F5!F' G<C K BŁ

I G9F '8 F97 HC B' C: '1 BIF99@B;
DC 7?9HBC H8915 @98

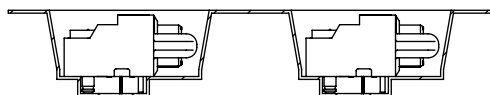

DFC.DF-915 FMBCH9

H: €8C 7! A 98H7 C B15 BG B: CFA 5HC B
7 C B: 89815 9588 DFC DF 945 FMB C
GSA H97 2 87 *588 G-588BC H69 F90FC 81 7 98
CF HF5BG 9F98 HC CH: 9F 8C 7! A 98HC F
8 47 @C 98 HC CH: 9FGC F! 98: C F 58M
DI FDC 09 CH: 9F H: 5B H: 5HK <? < #HK 5G
C 615 B 98 K #€ C! H: 9 9L DF 9098 K F #H8
7 C B 98HC: GSA H97 2 87 *

8C' B'CH G7 5 @9 8F5K B:

G: 99HG7 5 @9 %%

samtec

) &\$ D5F? 95GH6@ 8ZB9K '5 @5BM B (+) \$
D<C B9 ; %&L - ((! * + SL ; %&L - () \$ (+
YIA UJ) ; bž 4 GSA H97 *Wc a W€XY.)' &&

89G7 F @HC B.
"*) a a '8I 5@FC K F ÷ <H5B; @D@ ; '5G9A 6@M

8K : "BC"
E A GLLL!LL!LL!8!F5!LLL!LL

6M ?BCK @9B , #&) #&\$ \$* G<99H('C: (