

## DS34C86 Quad CMOS Differential Line Receiver

### Features

- Low power CMOS design
- $\pm 0.2V$  sensitivity over the entire common mode range
- Typical propagation delays: 20 ns
- Typical input hysteresis: 50 mV
- Inputs won't load line when  $V_{cc} = 0V$
- Meets the requirements of EIA standard RS-422
- TRI-STATE outputs for connection to system buses

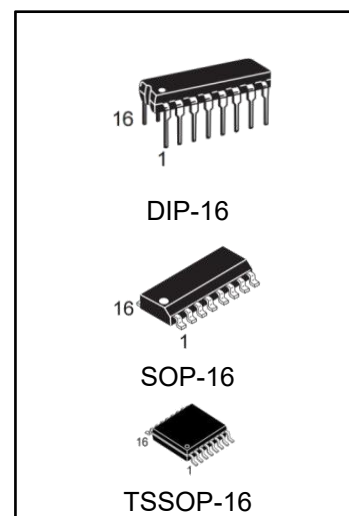

### Ordering Information

DEVICE	Package Type	MARKING	Packing	Packing Qty
DS34C86PG	DIP-16	DS34C86	TUBE	1000pcs/box
DS34C86DRG	SOP-16	DS34C86	REEL	2500pcs/reel
DS34C86DRG4	SOP-16	DS34C86	REEL	4000pcs/reel
DS34C86PWRG	TSSOP-16	34C86	REEL	2500pcs/reel

## General Description

The DS34C86 is a quad differential line receiver designed to meet the RS-422, RS-423, and Federal Standards 1020 and 1030 for balanced and unbalanced digital data transmission, while retaining the low power characteristics of CMOS.

The DS34C86 has an input sensitivity of 200 mV over the common mode input voltage range of  $\pm 7V$ . Hysteresis is provided to improve noise margin and discourage output instability for slowly changing input waveforms.

Separate enable pins allow independent control of receiver pairs. The TRI-STATE<sup>®</sup> outputs have 6 mA source and sink capability. The DS34C86 is pin compatible with the DS3486.

## Logic Diagram

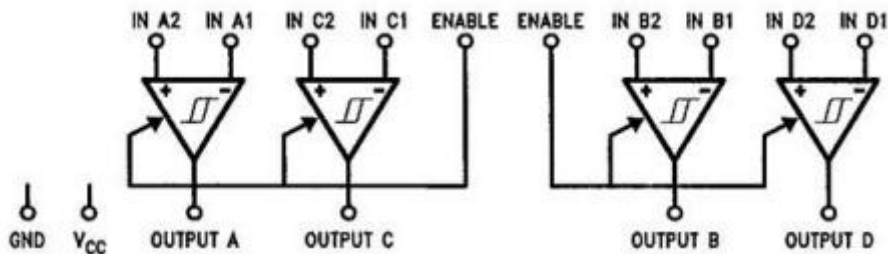

## Connection Diagram

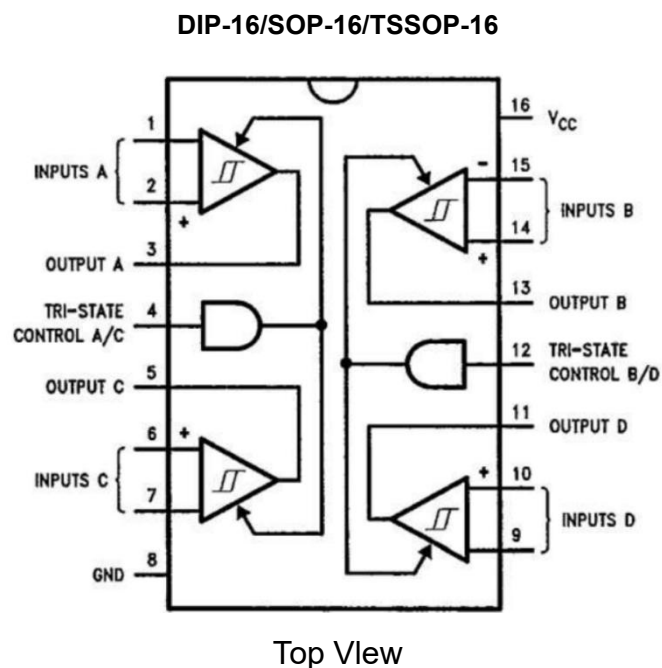

**Absolute Maximum Ratings** (Notes 1 & 2)

Condition	Min	Max	UNITS
Supply Voltage (V <sub>CC</sub> )	-	7	V
Common Mode Range (V <sub>CM</sub> )	-14	+14	V
Differential Input Voltage (V <sub>DIFF</sub> )	-14	+14	V
Enable Input Voltage (V <sub>IN</sub> )	-	7	V
Storage Temperature Range (T <sub>STG</sub> )	-65	+150	°C
Lead Temperature (Soldering 10 sec)	-	245	°C
Current Per Output	-25	+25	mA
<b>Operating Conditions</b>			
Supply Voltage (V <sub>CC</sub> )	4.75	5.25	V
Operating Temperature Range (T <sub>A</sub> )	-40	+85	°C
Enable Input Rise or Fall Times	-	500	ns

**DC Electrical Characteristics**

V<sub>CC</sub> = 5V +5% (unless otherwise specified) (Note 3)

Symbol	Parameter	Conditions	Min	Typ	Max	Units
V <sub>TH</sub>	Minimum Differential Input Voltage	V <sub>OUT</sub> = V <sub>OH</sub> or V <sub>OL</sub> -7V < V <sub>CM</sub> < +7V	-0.2		+0.2	V
R <sub>IN</sub>	Input Resistance	-7V < V <sub>CM</sub> < +7V (One Input AC GND)		10		kΩ
I <sub>IN</sub>	Input Current (Under Test)	V <sub>IN</sub> = +10V, Other Input GND V <sub>IN</sub> = -10V, Other Input = GND		+1.1 -1.6		mA mA
V <sub>OH</sub>	Minimum High Level Output Voltage	V <sub>CC</sub> =Min, V <sub>(DIFF)</sub> =+1V I <sub>OUT</sub> =6.0mA	3.84	4.2		V
V <sub>OL</sub>	Maximum Low Level Output Voltage	V <sub>CC</sub> =Max, V <sub>(DIFF)</sub> =+1V I <sub>OUT</sub> =6.0mA				V
V <sub>IH</sub>	Minimum Enable High Input Level Voltage		2.0			V
V <sub>IL</sub>	Maximum Enable Low Input Level Voltage				0.8	V
I <sub>oz</sub>	Maximum TRI-STATE Output Leakage Current	V <sub>OUT</sub> =V <sub>CC</sub> or GND, TRI-STATE Control=VIL		±0.5	±5.0	μA
I <sub>i</sub>	Maximum Enable Input Current	V <sub>IN</sub> =V <sub>CC</sub> or GND			±1.0	μA
I <sub>CC</sub>	Quiescent Power Supply Current	V <sub>CC</sub> =Max, V <sub>(DIFF)</sub> =+1V		12		mA
V <sub>HYST</sub>	Input Hysteresis			50		mV

## AC Electrical Characteristics

$V_{CC} = 5V \pm 5\%$  (unless otherwise specified) <sup>(Note 3)</sup>

Symbol	Parameter	Conditions	Min	Typ	Max	Units
$T_{PLH}$ , $t_{PHL}$	Propagation Delay Input to Output	$C_L=50pF$ $V_{DIFF}=2.5V$		20		ns
$t_{PLZ}$ , $t_{PHZ}$	Propagation Delay TRI-STATE Control to Output	$C_L=50pF$ $R_L+1000\Omega$ $V_{DIFF}=2.5v$		12		ns
$t_{PZL}$ , $t_{PZH}$	Propagation Delay TRI-STATE Control to Output	$C_L=50pF$ $R_L=1000\Omega$ $V_{DIFF}=2.5V$		14		ns

Note 1: Absolute Maximum Ratings indicate limits beyond which damage to the device may occur. Operating Ratings indicate conditions for which the device is intended to be functional, but specific performance is not ensured.

Note 2: Unless otherwise specified, all voltages are referenced to ground.

Note 3: Unless otherwise specified, Min/Max limits apply across the  $-40^{\circ}C$  to  $+65^{\circ}C$  temperature ranger All typicals are given for  $V_{ca} 5V$  and  $T_A = 25^{\circ}C$ .

### Propagation Delay

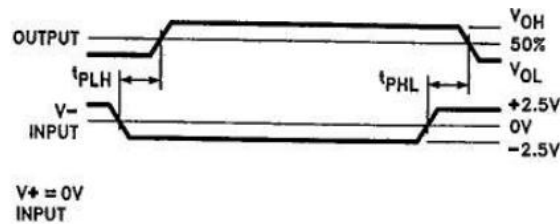

### Test Circuit for TRI-STATE Output Tests

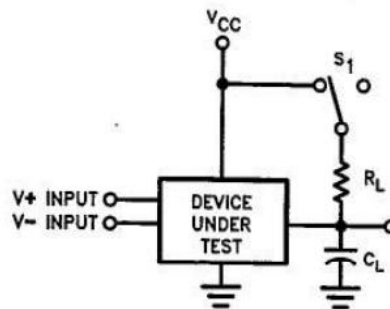

$C_L$  = Includes load and test jig capacitance.

$S1 = V_{CC}$  for  $t_{pzu}$ , and  $t_{pLz}$  measurements.

$S1 = GND$  for  $t_{pZH}$ , and  $t_{pHz}$  measurements.

### TRI-STATE Output Enable and Disable Waveforms

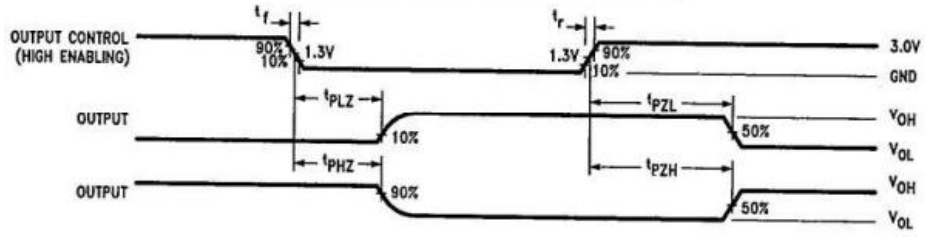

## Physical Dimensions

### DIP-16

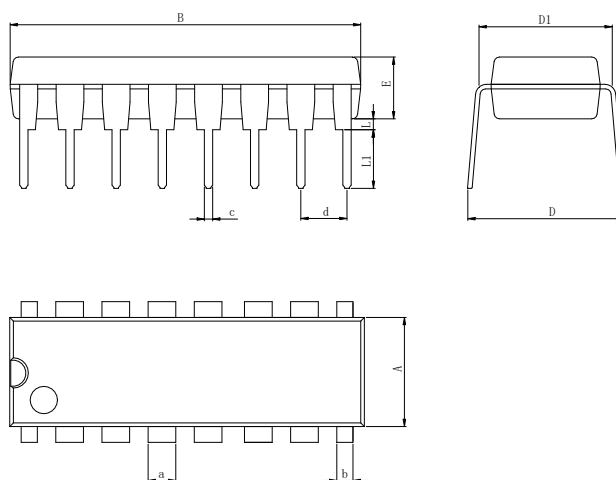

Dimensions In Millimeters(DIP-16)											
Symbol:	A	B	D	D1	E	L	L1	a	b	c	d
Min:	6.10	18.94	8.10	7.42	3.10	0.50	300	1.50	0.85	0.40	2.54 BSC
Max:	6.68	19.56	10.9	7.82	3.55	0.70	3.60	1.55	0.90	0.50	

### SOP-16

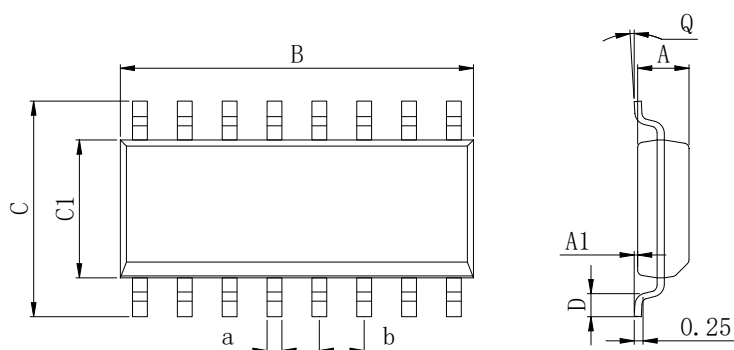

Dimensions In Millimeters(SOP-16)									
Symbol:	A	A1	B	C	C1	D	Q	a	b
Min:	1.35	0.05	9.80	5.80	3.80	0.40	0°	0.35	1.27 BSC
Max:	1.55	0.20	10.0	6.20	4.00	0.80	8°	0.45	

## Physical Dimensions

TSSOP-16

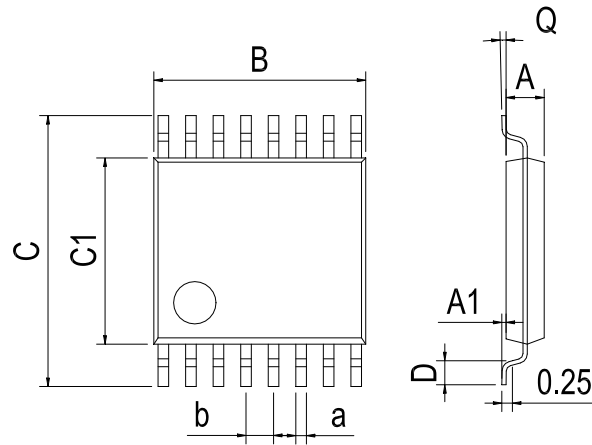

Dimensions In Millimeters(TSSOP-16)									
Symbol:	A	A1	B	C	C1	D	Q	a	b
Min:	0.85	0.05	4.90	6.20	4.30	0.40	0°	0.20	0.65 BSC
Max:	0.95	0.20	5.10	6.60	4.50	0.80	8°	0.25	

## Revision History

REVISION NUMBER	DATE	REVISION	PAGE
V1.0	2014-6	New	1-8
V1.1	2023-9	Update encapsulation type、 Update Lead Temperature、 Updated DIP-16 dimension、 Add annotation for Maximum Ratings.	1、 3、 6

**IMPORTANT STATEMENT:**

Hanschip Semiconductor reserves the right to change its products and services without notice. Before ordering, the customer shall obtain the latest relevant information and verify whether the information is up to date and complete. Hanschip Semiconductor does not assume any responsibility or obligation for the altered documents.

Customers are responsible for complying with safety standards and taking safety measures when using Hanschip Semiconductor products for system design and machine manufacturing. You will bear all the following responsibilities: select the appropriate Hanschip Semiconductor products for your application; Design, validate and test your application; Ensure that your application meets the appropriate standards and any other safety, security or other requirements. To avoid the occurrence of potential risks that may lead to personal injury or property loss.

Hanschip Semiconductor products have not been approved for applications in life support, military, aerospace and other fields, and Hanschip Semiconductor will not bear the consequences caused by the application of products in these fields. All problems, responsibilities and losses arising from the user's use beyond the applicable area of the product shall be borne by the user and have nothing to do with Hanschip Semiconductor, and the user shall not claim any compensation liability against Hanschip Semiconductor by the terms of this Agreement.

The technical and reliability data (including data sheets), design resources (including reference designs), application or other design suggestions, network tools, safety information and other resources provided for the performance of semiconductor products produced by Hanschip Semiconductor are not guaranteed to be free from defects and no warranty, express or implied, is made. The use of testing and other quality control technologies is limited to the quality assurance scope of Hanschip Semiconductor. Not all parameters of each device need to be tested.

The documentation of Hanschip Semiconductor authorizes you to use these resources only for developing the application of the product described in this document. You have no right to use any other Hanschip Semiconductor intellectual property rights or any third party intellectual property rights. It is strictly forbidden to make other copies or displays of these resources. You should fully compensate Hanschip Semiconductor and its agents for any claims, damages, costs, losses and debts caused by the use of these resources. Hanschip Semiconductor accepts no liability for any loss or damage caused by infringement.