

# 承認書

SPECIFICATION FOR APPROVAL

NO: CMT08050315

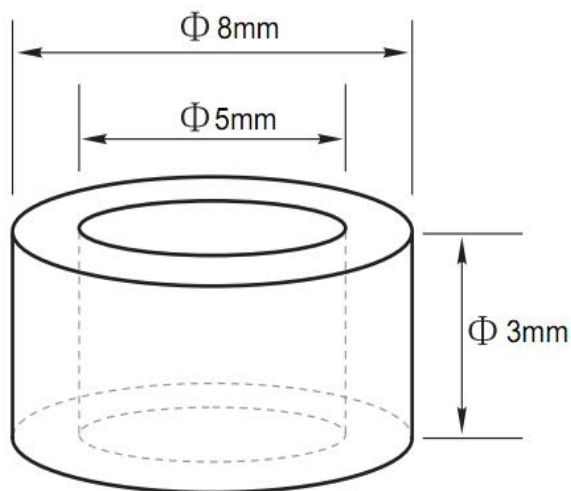

PRODUCTION CORD

CMT08050315

性能測試數據	
Core Factor	5.43mm <sup>-1</sup>
Le (mm <sup>-1</sup> )	25.63
Ae (mm <sup>2</sup> )	4.23
Ve (mm <sup>3</sup> )	105.35

DIMENSION			MATERIAL			TESTING CONDITION		CUSTOMER
尺寸			材料			測試條件		客戶名稱
Measuring unit: mm			NT2			測試儀器: TH2826A		
OD	8.00	±0.5	初始磁導率		5500 (10KHZ)	T=25°C 1000V 1mA 3sec 1TS		
ID	5.00	±0.5	比損耗因子	<15x10 <sup>-6</sup>	10KHz	AL:1.5-2.0uH 1KHz/0.1V 100Ω		
HT	3.00	±0.3	飽和磁通密度	≥240 (80°C)	≥380 (25°C)	DATE: 2025/4/1		