

### Features

- Typical Quiescent Current of 3 $\mu$ A
- No External Components
- V<sub>CC</sub> Transient Immunity
- Correct Logic Output Guaranteed to V<sub>CC</sub>=1.0V
- Push-Pull Low Active Reset Output
- Packages SOT23

### Applications

- Computers
- Embedded Systems
- Battery-Powered Equipments
- Intelligent Instruments
- CPU and Logic Circuit Reset
- Power Fail Detectors
- Automotive

### Pin Definition

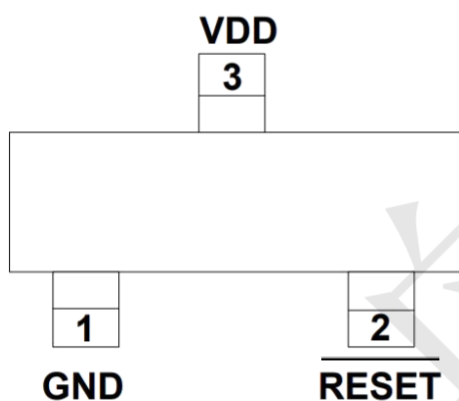

### Ordering Information

MAX809MTRG-TP  
 PACKAGE TYPE  
 SOT23

#### RESET VOLTAGE

L=4.63V  
 M=4.38V  
 J=4.00V  
 T=3.08V  
 S=2.93V  
 R=2.63V

### PIN CONFIGURATION

PIN	NAME	FUNCTION
1	GND	Ground
2	RESET	RESET output remains low while VCC is below the reset voltage threshold, and for a reset timeout period after VCC rises above reset threshold
3	VCC	Supply Voltage .

### Absolute Maximum Ratings (Note 1)

Symbol	Parameter	Value	UNIT
VCC	Any pin with respect to ground	-0.3 to +6.0	V
ICC	Input Current, VCC	20	mA
IO	Output Current, RESET	20	mA
	Rate of Rise, VCC	100	V/ $\mu$ s
PD	Continuous Power Dissipation	250	mW
TA	Operating Temperature Range	-40 to +85	$^{\circ}$ C
TSTG	Storage Temperature Range	-65 to +105	$^{\circ}$ C
R $^{\theta}$ JC	Thermal Resistance from Junction to Case	110	$^{\circ}$ C/W
R $^{\theta}$ JA	Thermal Resistance from Junction to Ambient	250	$^{\circ}$ C/W

### TYPICAL APPLICATION CIRCUIT

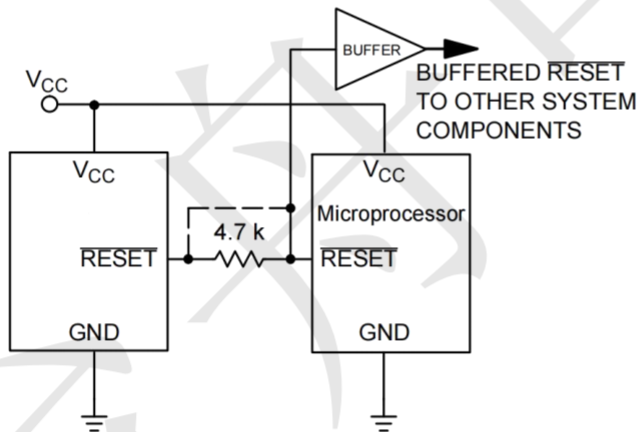

### FUNCTIONAL BLOCK DIAGRAM

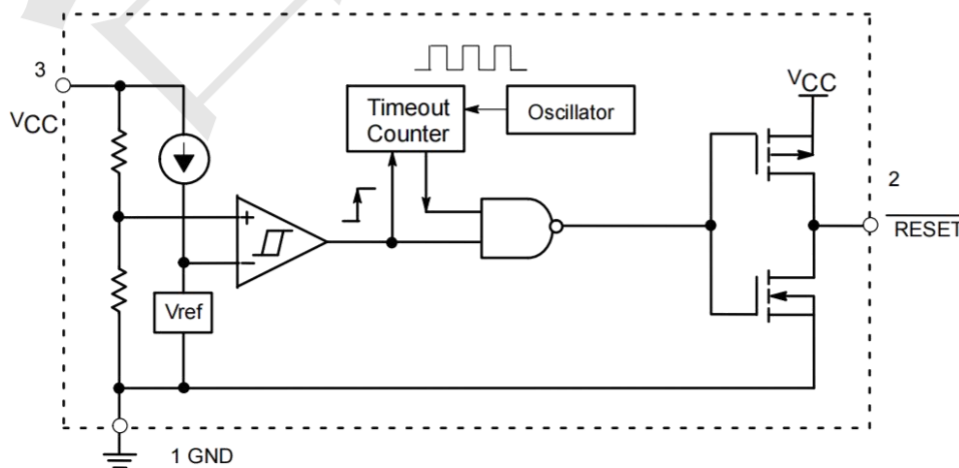

Series Complementary Active-Low Output

### Electrical Characteristics

Symbol	Parameter	Conditions	Min	Typ	Max	Unit	
	V <sub>CC</sub> Range	T <sub>A</sub> =0°C to +70°C	1.0		5.5	V	
I <sub>CC</sub>	Supply Current	V <sub>CC</sub> <5.5V, L/M/J		3	5	μA	
		V <sub>CC</sub> <3.6V, R/S/T/Z		3	5		
V <sub>TH</sub>	Reset Threshold	L	T <sub>A</sub> =+25°C	4.49	4.63	4.72	V
			T <sub>A</sub> =-40°C to +85°C	4.44		4.76	
		M	T <sub>A</sub> =+25°C	4.29	4.38	4.51	
			T <sub>A</sub> =-40°C to +85°C	4.25		4.55	
		J	T <sub>A</sub> =+25°C	3.90	4.00	4.10	
			T <sub>A</sub> =-40°C to +85°C	3.86		4.14	
		T	T <sub>A</sub> =+25°C	3.02	3.08	3.18	
			T <sub>A</sub> =-40°C to +85°C	2.99		3.21	
		S	T <sub>A</sub> =+25°C	2.83	2.93	2.97	
			T <sub>A</sub> =-40°C to +85°C	2.80		3.00	
		R	T <sub>A</sub> =+25°C	2.54	2.63	2.67	
			T <sub>A</sub> =-40°C to +85°C	2.51		2.69	
Reset Threshold Tempco				30		ppm/°C	
V <sub>CC</sub> to Reset Delay		V <sub>CC</sub> =V <sub>TH</sub> to (V <sub>TH</sub> -100mV)		10		μs	
Reset Active Timeout Period		T <sub>A</sub> =-40°C to +85°C	140	240	360	ms	
V <sub>OL</sub>	RESET Output Voltage Low (Push-Pull Active Low)	V <sub>CC</sub> =V <sub>TH</sub> min, I <sub>SINK</sub> =1.2mA, S/T/Z			0.3	V	
		V <sub>CC</sub> =V <sub>TH</sub> min, I <sub>SINK</sub> =3.2mA, J/L/M			0.4		
		V <sub>CC</sub> ≤1.0V, I <sub>SINK</sub> =50μA			0.3		
V <sub>OH</sub>	RESET Output Voltage High (Push-Pull Active Low)	V <sub>CC</sub> >V <sub>TH</sub> max, I <sub>SOURCE</sub> =500μA, S/T/Z	0.8V <sub>CC</sub>			V	
		V <sub>CC</sub> >V <sub>TH</sub> max, I <sub>SOURCE</sub> =800μA, J/L/M	V <sub>CC</sub> -1.5				

Note 1: Production testing done at T<sub>A</sub>=+25°C; limits over temperature guaranteed by design only.

### Typical Operating Characteristics

(VCC = Full range, TA = -40°C to +85°C unless otherwise noted. Typical values at TA = +25°C and VCC = 5 V for the L/M/J versions, VCC = 3.3 V for the T/S versions, VCC = 3 V for the R version and VCC = 2.5 V for the Z version.)

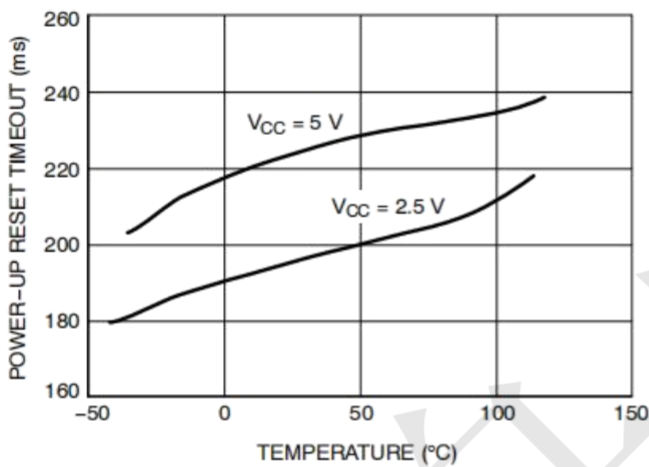

Power-Up Reset Timeout vs. Temperature

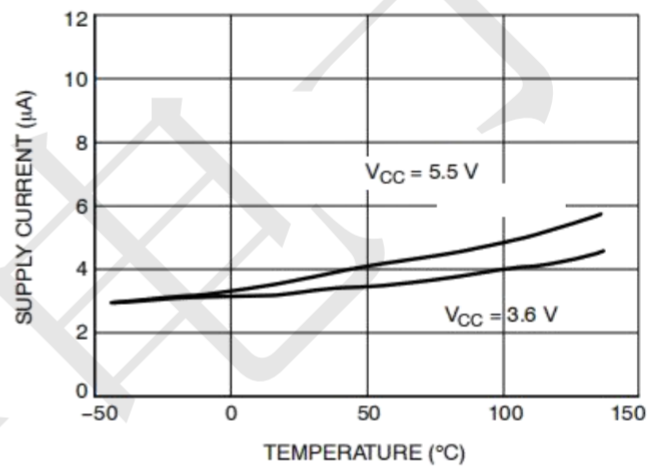

Supply Current vs. Temperature (No Load, )

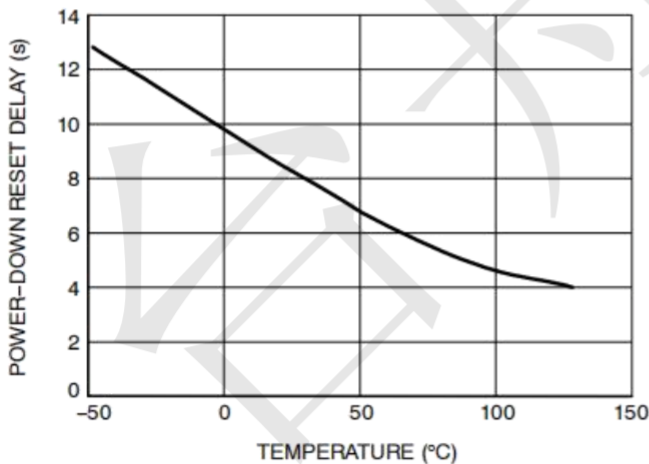

Power-Down Reset Delay vs. Temperature

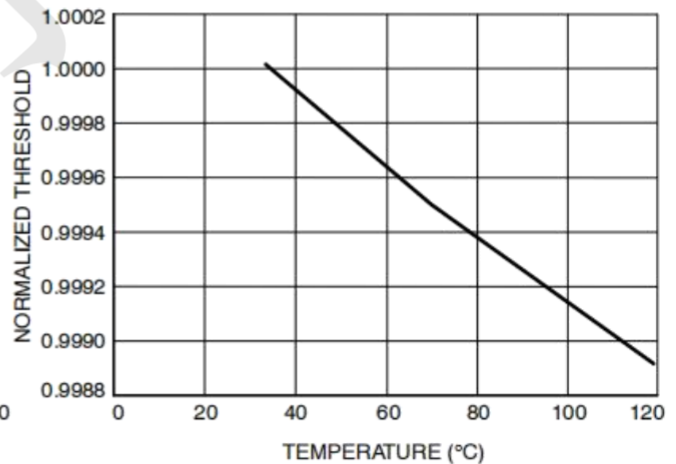

Normalized Reset Threshold vs. Temperature

### Package Outline Dimensions (unit: mm)

SOT23

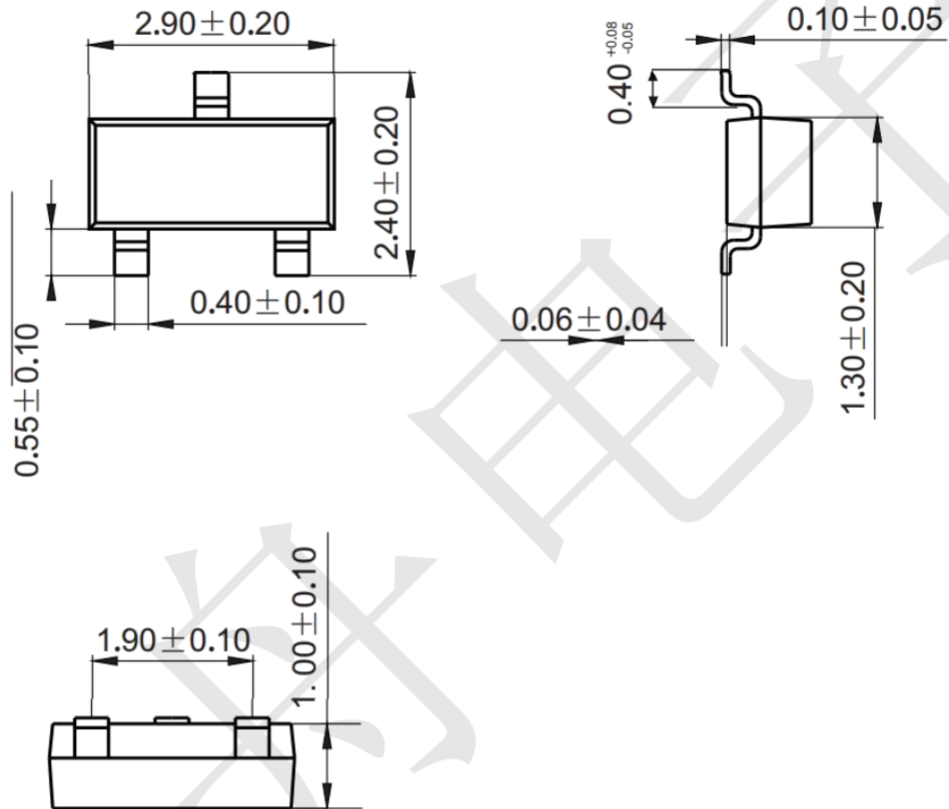

### Mounting Pad Layout (unit: mm)

