

标记 MARK		ECN编号/变更内容 ECN NO/DEFINITION				修改 REVISE		日期 DATE		核准 APPROVE	
PIN	DIM A	DIM B	PIN	DIM A	DIM B	PIN	DIM A	DIM B	PIN	DIM A	DIM B
1	—	2.54	11	25.40	27.94	21	50.80	53.34	31	76.20	78.74
2	2.54	5.08	12	27.94	30.48	22	53.34	55.88	32	78.74	81.28
3	5.08	7.62	13	30.48	33.02	23	55.88	58.42	33	81.28	83.82
4	7.62	10.16	14	33.02	35.56	24	58.42	60.96	34	83.82	86.36
5	10.16	12.70	15	35.56	38.10	25	60.96	63.50	35	86.36	88.90
6	12.70	15.24	16	38.10	40.64	26	63.50	66.04	36	88.90	91.44
7	15.24	17.78	17	40.64	43.18	27	66.04	68.58	37	91.44	93.98
8	17.78	20.32	18	43.18	45.72	28	68.58	71.12	38	93.98	96.52
9	20.32	22.86	19	45.72	48.26	29	71.12	73.66	39	96.52	99.06
10	22.86	25.40	20	48.26	50.80	30	73.66	76.20	40	99.06	101.60

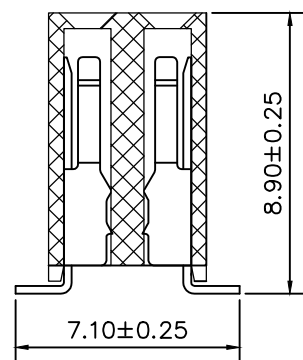
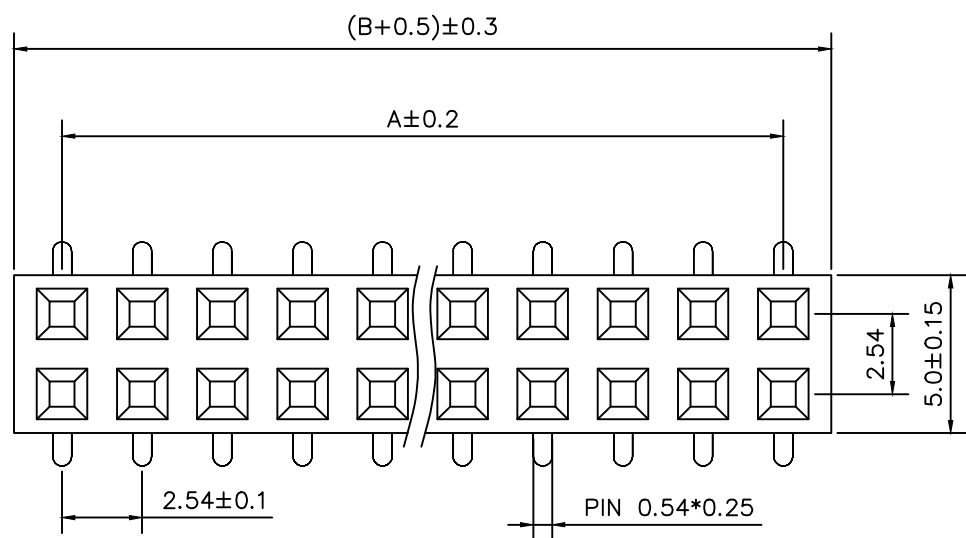

SPECIFICATIONS

Current Rating: 3 Amps
 Withstanding Voltage: AC 1000V
 Insulation Resistance: 1000MΩ Min
 Contact Resistance: 20mΩ Max
 Operation Temperature: -40°to+105°
 Insulator Material: Polyester
 Contact Material: Brass
 Standard: PA6T
 Contact Plating: Gold Flash
 Max.Processing Temp: 200°C for 30-60seconds
 (255°C for 5seconds)

H	PW	PB
8.5	7.1	8.9

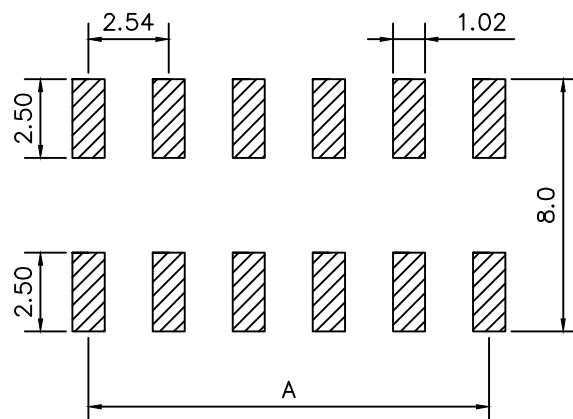
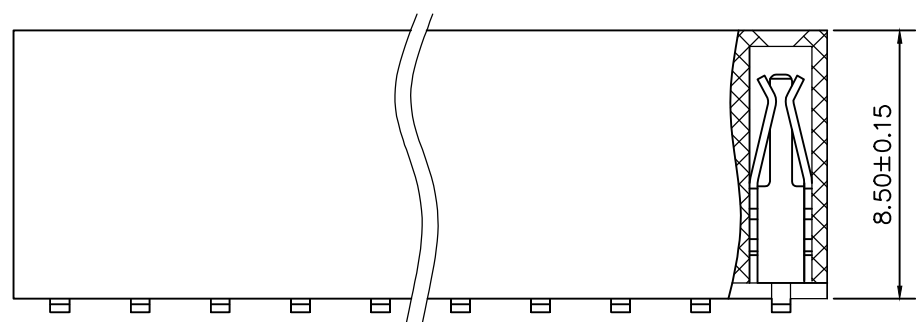

RECOMMEND P. C. B LAYOUT
 PCB TOLERANCE: ±0.05 (TOP VIEW)

2	接触	铜	镀金	
1	基座	PA6T	本色	
序号	品名	材质	电镀/颜色	备注

	深圳市虹成电子有限公司		品名 TITLE	排母		
			料号 PART NO	HC-PM254-8.5H-2x20PS		
一般公差 TOLERANCE		比列 SCALE	1:1			
X : ±0.30	X° : ±5°	单位 UNIT	MM	制图 DRAW		AhYe
X.X : ±0.25	X.X° : ±1°	张数 PART NO	1 OF 1	审核 CHECKED		夏操云
X.XX : ±0.20	X.XX° : ±0.5°	版本 REV	A	批准 APPROVE	赵亮亮	

