

REV NO	MARK	修改摘要 REVISION DESCRIPTION	签名 SIGNATURE	日期 DATE
		NEW DWG		2016-03-12

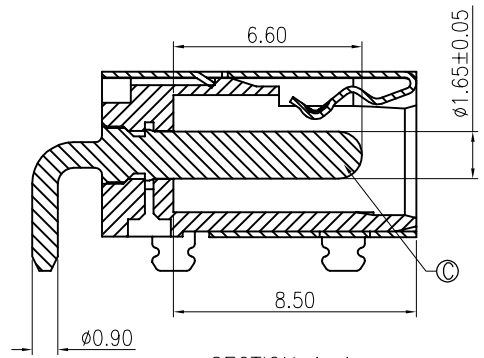

SECTION A-A

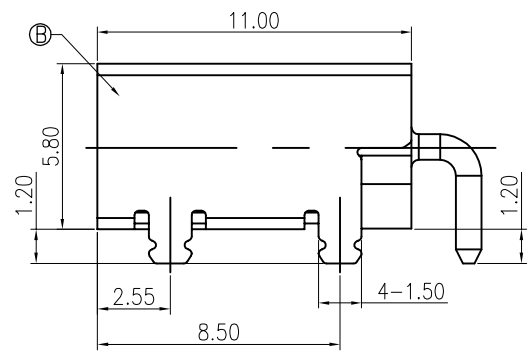
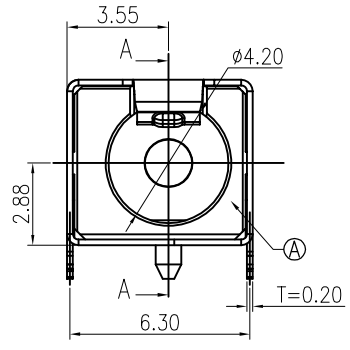

SPECIFICATION:

1. RATING: DC 20V 5A
2. CONTACT RESISTANCE: 30mΩ MAX.
3. INSULATION RESISTANCE: 100 MΩ MIN.
4. WITHSTAND VOLTAGE: 500 VAC
5. INSERTION FORCE: 5N~30N
6. EXTRACTION FORCE: 5N~30N
7. DURABILITY: 10,000 CYCLES

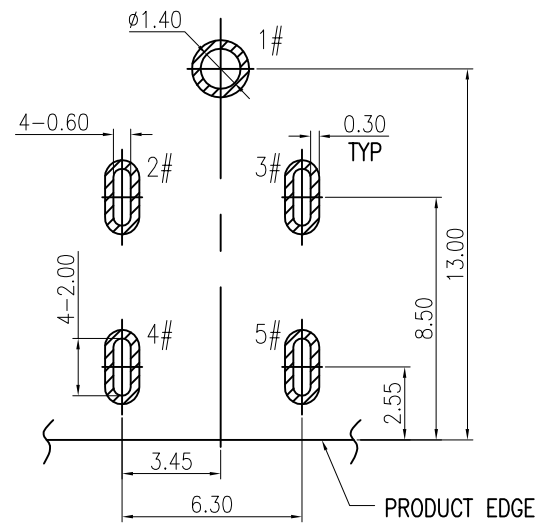

RECOMMENDED PCB LAYOUT(T=1.00)  
TOP VIEW TOLERANCE:±0.05

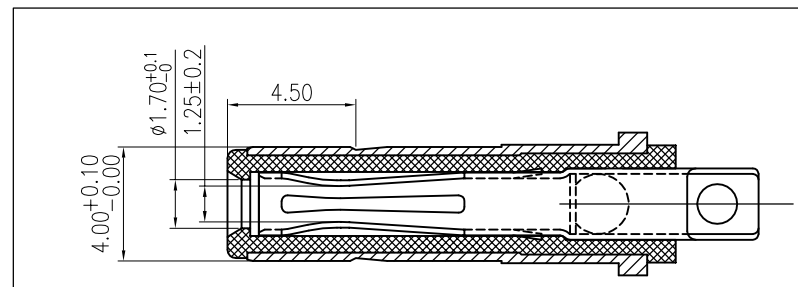
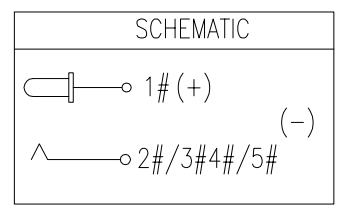
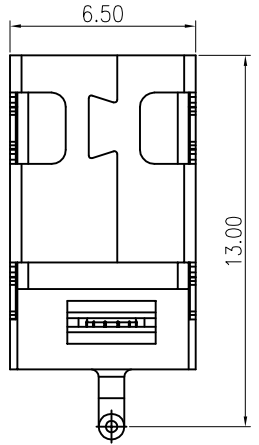

MATING PLUG  
DP400170-0038-6H

NO.	DESCRIPTION	MATERIAL	REMARKS	QTY
C	CENTER PIN	BRASS	GOLD FLASH"/Ni 40u"	1
B	SHELL	COPPER ALLOY	Ni 40u"	1
A	HOUSING	HIGH TEMP.THERMOPLASTIC	BLACK	1



深圳市华德共创科技有限公司  
Shenzhen Huade co-create Technology Co.,LTD  
电话: 0755-27111216 传真: 0755-29940187

-TOLERANCES- UNLESS OTHERWISE SPECIFIED 公差参数表		TITLE: DC Power Jack 4017 大电流8A, 卧式, 产品名称: 高可靠, 四脚插板 CL=2.88	
X.X	±0.30	X.X*	±3°
X.XX	±0.20	X.XX*	±2°
X.XXX	±0.10	X.XXX*	±1°
APPD: 核准:	王建业	PART NO: 产品编号:	DC400170-0911-2H
CHECK: 校对:	黄艳兰	DATE	SCALE
DRAW: 绘图:	2016-03-12	UNIT	CODE NUMBER
	1:1	mm	A001