

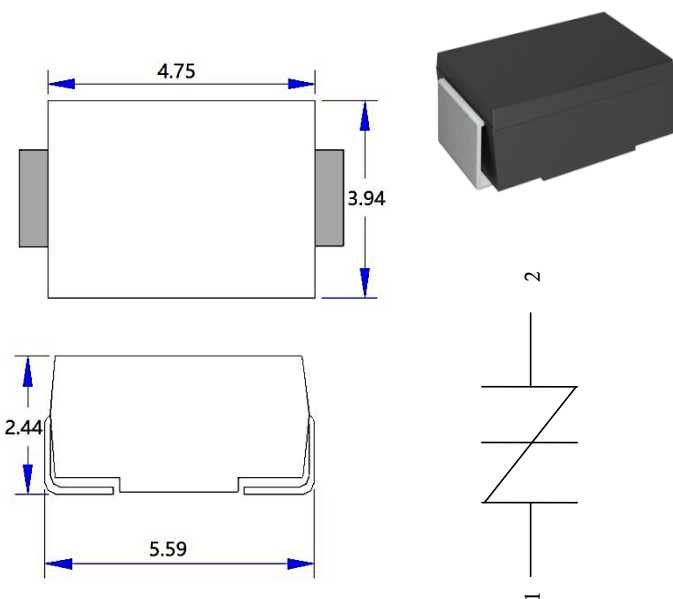
## Description

PXXXXSC series thyristors are a type of semi-conduct component. They are designed in modems, telephones, line cards, answering machines, FAX machines, SLICs, T1/E1, xDSL, PBXs and more applications.

## Features

- Surface mount package to optimize board space
- Low profile package
- Bidirectional crowbar protection
- Low leakage current :  $I = 5\mu\text{A max}$
- Low on-state voltage
- Low Capacitance
- Solid-state silicon technology
- Eliminates overvoltage caused by fast rising transients

## Dimensions & Symbol (Unit: mm Max)



## Mechanical Characteristics

- Package: SMB/DO-214AA
- Case Material: "Green" Molding Compound.
- Standard Packaging: 12mm tape (EIA STD RS-481)
- Weight: 0.10g
- Terminal Connections: See Diagram Below
- Marking Information: See Below

## Applications Standards

- TIA-968-A/B
- ITU K.20/21 Enhanced Level\*
- ITU K.20/21 Basic Level\*
- GR 1089 Inter-building\*
- GR 1089 Intra-building
- IEC 61000-4-5 2nd edition
- YD/T 1082 YD/T 993 YD/T 950

## Ordering Information

| Out line | Reel (pcs) | Per carton (pcs) | Reel diameters (mm) |
|----------|------------|------------------|---------------------|
| Taping   | 3K         | 48K              | 330                 |

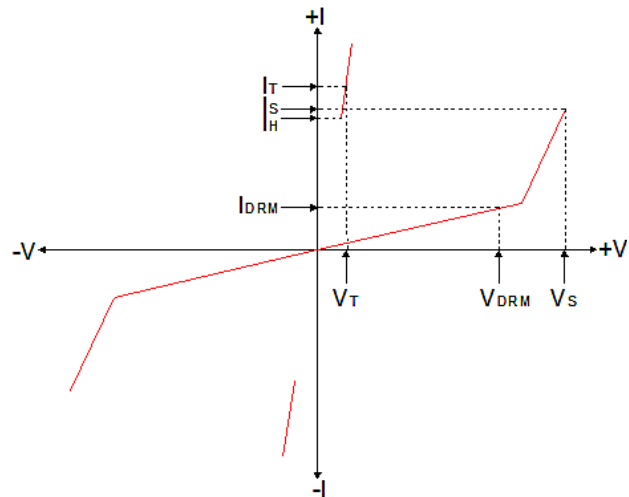
**Absolute Maximum Ratings** ( $T_A=25^{\circ}\text{C}$ , RH=45%-75%, unless otherwise noted)

| Parameter                            | Symbol    | Value       | Unit               |
|--------------------------------------|-----------|-------------|--------------------|
| Storage temperature range            | $T_{stg}$ | -60 to +150 | $^{\circ}\text{C}$ |
| Operating junction temperature range | $T_j$     | -40 to +150 | $^{\circ}\text{C}$ |
| Repetitive peak pulse current        | $I_{PP}$  | 150         | A                  |

**Electrical Characteristics Curve** ( $T_A=25^{\circ}\text{C}$ )

| Symbol    | Parameter              |
|-----------|------------------------|
| $V_{DRM}$ | Peak off-state voltage |
| $I_{DRM}$ | Off-state current      |
| $V_S$     | Switching voltage      |
| $I_S$     | Switching current      |
| $V_T$     | On-state voltage       |
| $I_T$     | On-state current       |
| $I_H$     | Holding current        |
| $C_O$     | Off-state capacitance  |

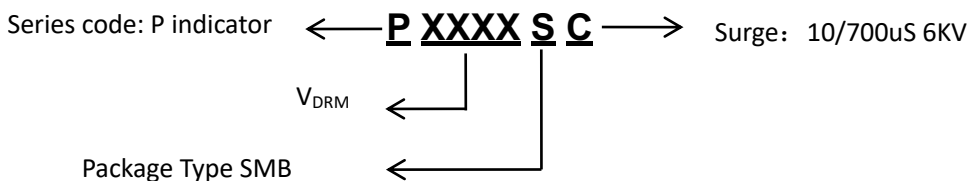
V-I Curve



**Surge Ratings**

| Series | $I_{PP}$ (A) min |        |          |           |
|--------|------------------|--------|----------|-----------|
|        | 2×10us           | 8×20us | 10×360us | 10×1000us |
| C      | 500              | 400    | 175      | 100       |

**Part Number Code**



**Electrical Characteristics (T<sub>A</sub>=25°C,)**

| Part Number | Marking       | I <sub>DRM</sub> @V <sub>DRM</sub> |     | V <sub>S</sub> <sup>①</sup> @I <sub>S</sub> |      | V <sub>T</sub> @ I <sub>T</sub> |     | I <sub>H</sub> | C <sub>O</sub> <sup>②</sup> |
|-------------|---------------|------------------------------------|-----|---|------|---------------------------------|-----|----------------|-----------------------------|
|             |               | μA                                 | V   | V   | mA   | V                               | A   | mA             | pF                          |
|             |               | max                                | min | max   | max  | max                             | max | min            | max                         |
| P0080SC     | P008C<br>YYWW | 5                                  | 6   | 20  | 800  | 4                               | 2.2 | 25             | 80                          |
| P0220SC     | P02C<br>YYWW  | 5                                  | 15  | 28  | 800  | 4                               | 2.2 | 35             | 80                          |
| P0300SC     | P03C<br>YYWW  | 5                                  | 25  | 40  | 800  | 4                               | 2.2 | 50             | 80                          |
| P0640SC     | P06C<br>YYWW  | 5                                  | 58  | 77  | 800  | 4                               | 2.2 | 120            | 65                          |
| P0720SC     | P07C<br>YYWW  | 5                                  | 65  | 88  | 800  | 4                               | 2.2 | 120            | 65                          |
| P0900SC     | P09C<br>YYWW  | 5                                  | 75  | 98  | 800  | 4                               | 2.2 | 120            | 65                          |
| P1100SC     | P110C<br>YYWW | 5                                  | 90  | 130   | 800  | 4                               | 2.2 | 120            | 65                          |
| P1300SC     | P13C<br>YYWW  | 5                                  | 120 | 160   | 800  | 4                               | 2.2 | 120            | 65                          |
| P1500SC     | P15C<br>YYWW  | 5                                  | 140 | 180   | 800  | 4                               | 2.2 | 120            | 65                          |
| P1800SC     | P18C<br>YYWW  | 5                                  | 170 | 220   | 800  | 4                               | 2.2 | 120            | 60                          |
| P2000SC     | P20C<br>YYWW  | 5                                  | 180 | 220   | 800  | 4                               | 2.2 | 120            | 60                          |
| P2300SC     | P23C<br>YYWW  | 5                                  | 190 | 260   | 800  | 4                               | 2.2 | 120            | 60                          |
| P2600SC     | P26C<br>YYWW  | 5                                  | 220 | 300   | 800  | 4                               | 2.2 | 120            | 55                          |
| P3100SC     | P31C<br>YYWW  | 5                                  | 275 | 350   | 800  | 4                               | 2.2 | 120            | 70                          |
| P3500SC     | P35C<br>YYWW  | 5                                  | 320 | 400   | 800  | 4                               | 2.2 | 120            | 50                          |
| P3800SC     | P38C<br>YYWW  | 5                                  | 360 | 460   | 800  | 4                               | 2.2 | 120            | 50                          |
| P4200SC     | P42C<br>YYWW  | 5                                  | 400 | 540   | 800  | 4                               | 2.2 | 120            | 45                          |
| P8000SC     | P80C<br>YYWW  | 5                                  | 800 | 900   | 1350 | 4                               | 2.2 | 55(max.)       | 40                          |

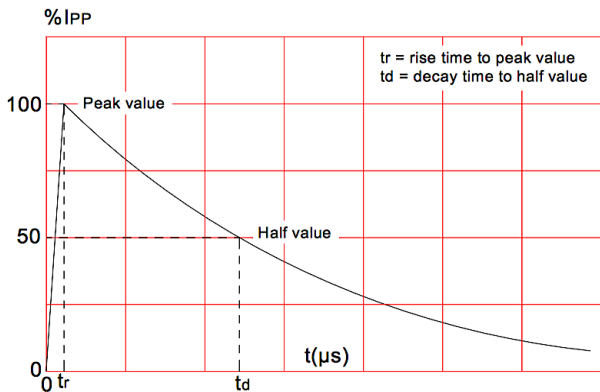
① V<sub>S</sub> is measured at 100KV/s

② Off-state capacitance is measured in V<sub>DC</sub>=2V, V<sub>RMS</sub>=1V, f=1MHz

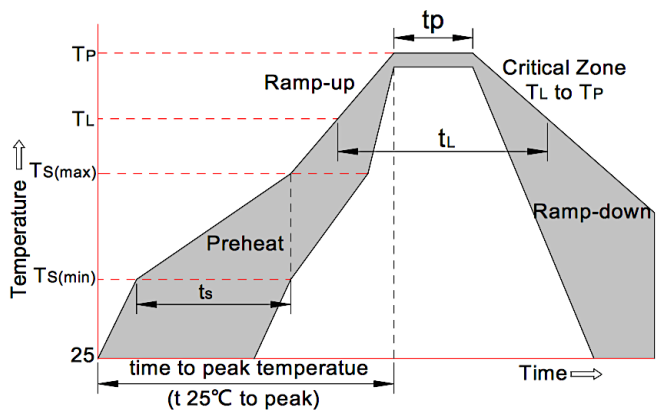
**Soldering Parameters**

| Reflow Condition  |                                    | Pb-Free assembly |
|---|------------------------------------|------------------|
| Pre Heat  | -Temperature Min ( $T_{s(min)}$ )  | +150°C           |
|   | -Temperature Max ( $T_{s(max)}$ )  | +200°C           |
|   | -Time (Min to Max) ( $t_s$ )       | 60-180 secs.     |
| Average ramp up rate (Liquid us Temp ( $T_L$ ) to peak) |                                    | 3°C/sec. Max     |
| $T_{s(max)}$ to $T_L$ - Ramp-up Rate                    |                                    | 3°C/sec. Max     |
| Reflow  | -Temperature ( $T_L$ ) (Liquid us) | +217°C           |
|   | -Temperature( $t_L$ )              | 60-150 secs.     |
| Peak Temp ( $T_p$ )                                     |                                    | +260(+0/-5)°C    |
| Time within 5°C of actual Peak Temp ( $t_p$ )           |                                    | 30 secs. Max     |
| Ramp-down Rate  |                                    | 6°C/sec. Max     |
| Time 25°C to Peak Temp ( $T_p$ )                        |                                    | 8 min. Max       |
| Do not exceed   |                                    | +260°C           |

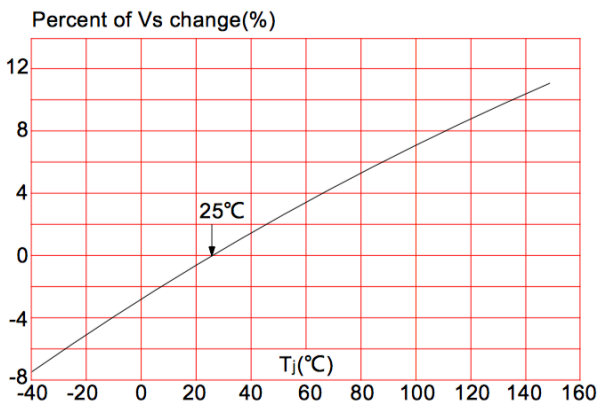
**FIG.1:**  $t_r \times t_d$  pulse waveform



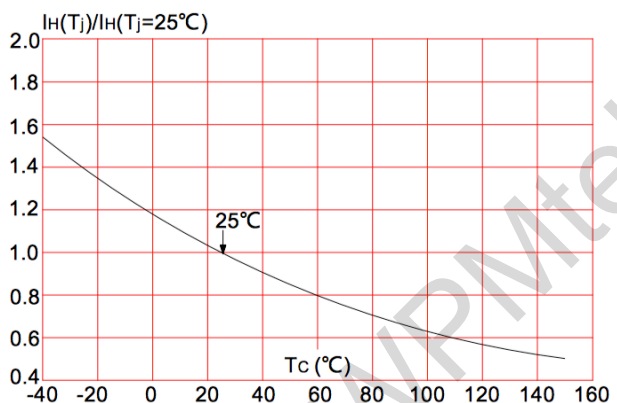
**FIG.2:** Reflow condition



**FIG.3:** Normalized  $V_s$  change vs. junction temperature

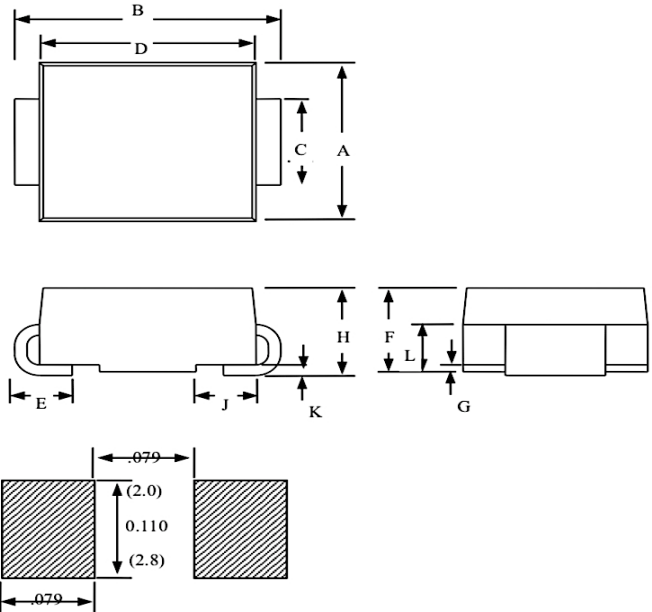


**FIG.4:** Normalized DC holding current vs. case temperature

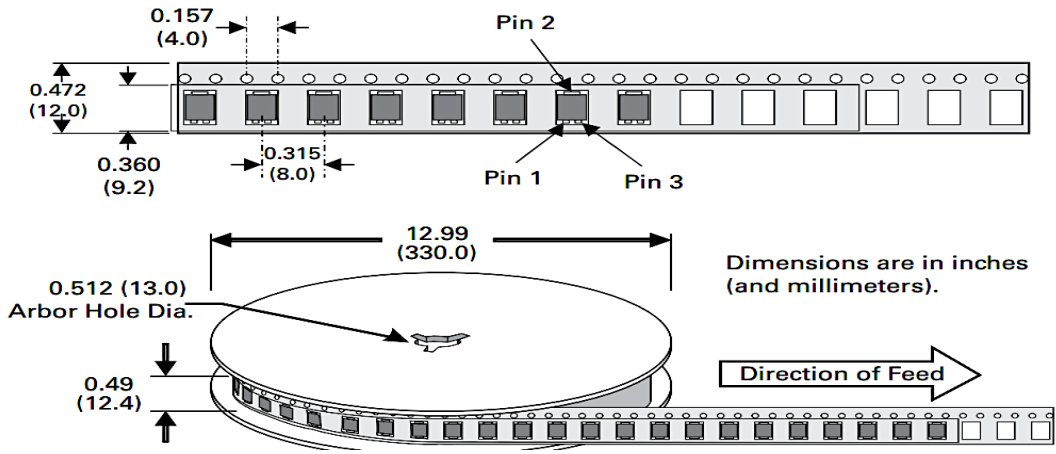


**Package Mechanical Data**

| Dimension | Inches |       | Millimeters |      |
|-----------|--------|-------|-------------|------|
|           | MIN    | MAX   | MIN         | MAX  |
| A         | 0.134  | 0.155 | 3.40        | 3.94 |
| B         | 0.205  | 0.22  | 5.21        | 5.59 |
| C         | 0.075  | 0.083 | 1.90        | 2.11 |
| D         | 0.166  | 0.185 | 4.22        | 4.70 |
| E         | 0.036  | 0.056 | 0.91        | 1.42 |
| F         | 0.073  | 0.087 | 1.85        | 2.2  |
| G         | 0.002  | 0.008 | 0.05        | 0.20 |
| H         | 0.077  | 0.094 | 1.95        | 2.40 |
| J         | 0.043  | 0.053 | 1.09        | 1.35 |
| K         | 0.008  | 0.014 | 0.20        | 0.35 |
| L         | 0.039  | 0.049 | 0.99        | 1.24 |



**Tape & Reel Specification - SMB**



WPMtek reserves the right to make changes to the product specification and data in this document without notice. WPMtek makes no warranty, representation or guarantee regarding the suitability of its products for any particular purpose, nor does WPMtek assume any liability arising from the application or use of any products or circuits, and specifically disclaims any and all liability, including without limitation special, consequential or incidental damages. Any enquiry, please write to sales@wpmtek.com for further information.