



LOW NOISE, POSITIVE GAIN SLOPE

Wideband Amplifier

PMA-183PLN+

50Ω 6 to 18 GHz

THE BIG DEAL

- Wideband, 6 to 18 GHz
- Excellent Noise Figure, 1.2 dB at 15 GHz
- Positive Gain Slope
- High Directivity, 33 dB typ.

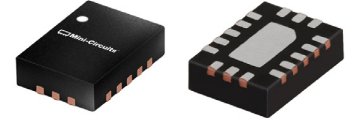

Generic photo used for illustration purposes only
CASE STYLE: JV2579

+RoHS Compliant
The +Suffix identifies RoHS Compliance. See our web site for RoHS Compliance methodologies and qualifications

APPLICATIONS

- C,X & Ku-Band Radar
- Satellite Communication
- ELINT

PRODUCT OVERVIEW

The PMA-183PLN+ is a PHEMT* based wideband MMIC amplifier with an unique combination of high gain with positive gain slope, high directivity and low noise figure, making it ideal for receiver applications. This design operates on a single 2.6V supply, is well matched for 50Ω and comes in a tiny, low profile package (3.5 x 2.5 mm, 16-lead MCLP), accommodating dense circuit board layouts.

KEY FEATURES

Feature	Advantages
High Directivity	With active directivity of 33 dB, the PMA-183PLN+ is an excellent choice for buffering broadband circuits, eliminating the need for an expensive isolator in most cases.
Positive Gain Slope vs. Frequency <ul style="list-style-type: none"> • +0.21 dB/GHz (6-15 GHz) • +0.55 dB/GHz (15-18 GHz) 	Useful for compensating negative gain slope of most wideband microwave components and eliminating the need for equalization
Excellent Noise Figure up to 18 GHz <ul style="list-style-type: none"> • 1.2dB Typ. at 18GHz 	Enables lower system noise figure performance.
3.5 x 2.5mm, 16-lead MCLP package	Tiny footprint saves space in dense layouts while providing low inductance, repeatable transitions, and excellent thermal contact to the PCB.

4. Permanent damage may occur if any of these limits are exceeded.

REV. E
ECO-011027
PMA-183PLN+
GY/RS/CP
211209





LOW NOISE, POSITIVE GAIN SLOPE

Wideband Amplifier

PMA-183PLN+

ELECTRICAL SPECIFICATIONS¹ AT 25°C, UNLESS NOTED OTHERWISE

Parameter	Condition (MHz)	V _s =2.6V			Units
		Min.	Typ.	Max.	
Frequency Range		6		18	GHz
Gain	6000	20.7	26.3	29.1	dB
	10000	19.0	26.3	29.6	
	15000	20.8	27.5	30.3	
	18000	-	29.7	-	
Input Return Loss	6000		10.2		dB
	10000		14.8		
	15000		12.7		
	18000		9.1		
Output Return Loss	6000		11.4		dB
	10000		15.3		
	15000		16.9		
	18000		25.0		
Directivity	6000 - 18000		33		dB
Output Power at 1dB Compression ²	6000		9.8		dBm
	10000		8.6		
	15000		9.6		
	18000		10.2		
Output IP3	6000		25		dBm
	10000		22		
	15000		22.4		
	18000		21.9		
Noise Figure	6000		1.4		dB
	10000		1.3		
	15000		1.2		
	18000		1.3		
Device Operating Voltage (V _s)		2.3	2.6	2.9	V
Device Operating Current (I _{DD})		-	57.2	72	mA
Device Current Variation vs. Temperature ²			7.69		µA/°C
Device Current Variation vs. Voltage ³			0.04		mA/mV
Thermal Resistance, junction-to-ground lead			49.5		°C/W

1. Measured on Mini-Circuits Characterization Test Board TB-PMA-183PLN+. See Characterization Test & Application Circuit (Fig. 1)

2. Device Current Variation vs. Temperature = (Current in mA at 85°C - Current in mA at -45°C)/130°C

3. Device Current Variation vs. Voltage = (Current in mA at 2.9V - Current in mA at 2.3V) / ((2.9V - 2.3V)*1000 mA/mV)

MAXIMUM RATINGS^{3,4}

Parameter	Ratings
Operating Temperature (ground lead)	-40°C to 85°C
Storage Temperature	-65°C to 150°C
Junction Temperature	131°C
Total Power Dissipation	0.9W
Input Power (CW), V _s =2.6V	+24 dBm (5 minutes max.) +13 dBm (continuous)
DC Voltage on V _s	4V
DC Voltage on RF Ports (RF-IN & RF-OUT)	4V

4. Permanent damage may occur if any of these limits are exceeded. Electrical maximum ratings are not intended for continuous normal operation.





LOW NOISE, POSITIVE GAIN SLOPE

Wideband Amplifier

PMA-183PLN+

SIMPLIFIED SCHEMATIC & PAD DESCRIPTION

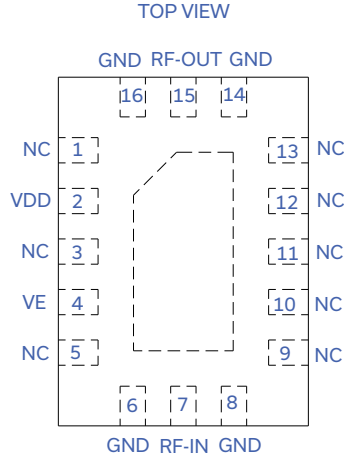
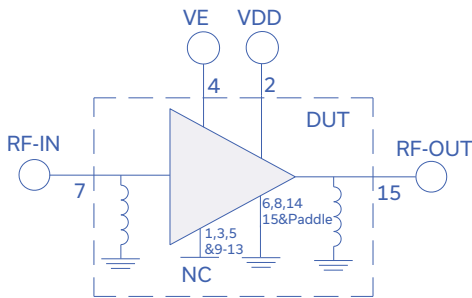

Function	Pad Number	Description (See Figure 1)
VDD	2	Supply Voltage Pad, Connects to Vs via R1
VE	4	Enable Voltage Pad, Connects to VDD via R2
RF-IN	7	RF Input Pad, Connects to the input port
RF-OUT	15	RF Output Pad, Connects to the output port
NC	1,3,5 & 9-13	No connection to the die, Grounded on the test board
GROUND	6,8,14,16 & Paddle	Connects to ground on Test board

CHARACTERIZATION TEST & APPLICATION CIRCUIT

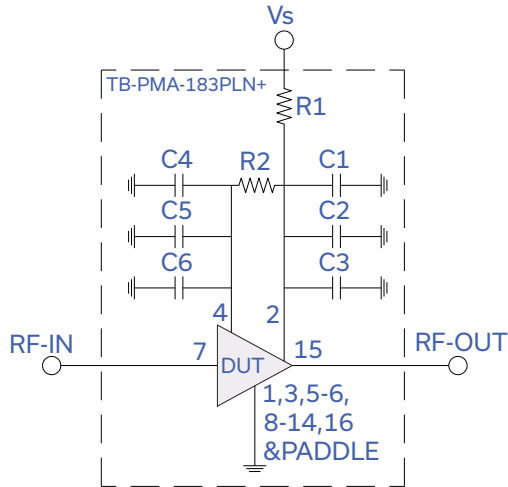

Fig 1. Application and Characterization Circuit

Note: This block diagram is used for characterization. (DUT soldered on Mini-Circuits Characterization test board TB-PMA-183PLN+) Gain, Return loss, Output power at 1dB compression (P1dB), output IP3 (OIP3) and noise figure measured using Agilent's N5242A PNA-X microwave network analyzer.

Conditions:

- Gain and Return loss: Pin= -25dBm
- Output IP3 (OIP3): Two tones, spaced 1 MHz apart, -10 dBm/tone at output.

Component	Size	Value	Part Number	Manufacturer
C1,C4	0805	0.33uF	TAJR334K035RNJ	AVX
C2,C5	0603	1000pF	GCM1885C1H102JA16D	Murata
C3,C6	0402	100pF	GRM1555C1H101JA01D	Murata
R1	0603	100hm	ESR03EZPF10R0	Rohm Semiconductor
R2	0402	4990hm	RN731ETTP4990B25	Koa Speer

PRODUCT MARKING

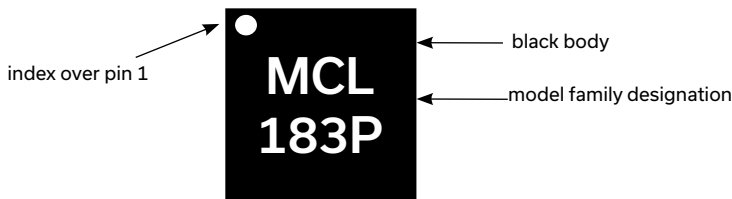

Marking may contain other features or characters for internal lot control





LOW NOISE, POSITIVE GAIN SLOPE

Wideband Amplifier

PMA-183PLN+

ADDITIONAL DETAILED TECHNICAL INFORMATION IS AVAILABLE ON OUR DASH BOARD. TO ACCESS [CLICK HERE](#)

Performance Data	Data Table Swept Graphs S-Parameter (S2P Files) Data Set (.zip file)
Case Style	JV2579 Plastic package, exposed paddle, lead finish: Matte-Tin Plate
Tape & Reel	F104
Standard quantities available on reel	7" reels with 2K devices
Suggested Layout for PCB Design	PL-691
Evaluation Board	TB-PMA-183PLN+ & TB-PMA-183PLNC+
Environmental Ratings	ENV08T1

ESD RATING

Human Body Model (HBM): Class 1C (1000 to <2000V) in accordance with ANSI/ESD STM 5.1 - 2001

MSL TEST FLOW CHART

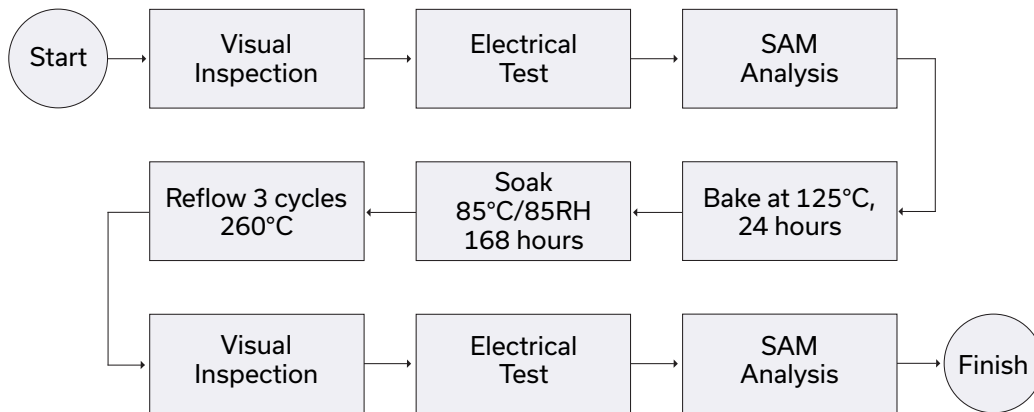

NOTES

- A. Performance and quality attributes and conditions not expressly stated in this specification document are intended to be excluded and do not form a part of this specification document.
- B. Electrical specifications and performance data contained in this specification document are based on Mini-Circuit's applicable established test performance criteria and measurement instructions.
- C. The parts covered by this specification document are subject to Mini-Circuits standard limited warranty and terms and conditions (collectively, "Standard Terms"); Purchasers of this part are entitled to the rights and benefits contained therein. For a full statement of the standard. Terms and the exclusive rights and remedies thereunder, please visit Mini-Circuits' website at www.minicircuits.com/MCLStore/terms.jsp

