

RoHS

NO.	COMPONENTS	MATERIALS	SPECIFICATION:FINISH/COLOR	QTY.
1	HOUSING	High temperature material	UL94V-0 Black	1
2	CONTACT	Phosphor bronze	SURFACE PLATING:TIN/Au	1
3	SHELL	Stainless steel	SURFACE PLATING:NI/TIN	1

NOTE(UNLESS OTHERWISE SPECIFIED):  
 1. ALL MATERIAL MUST BE COMPLY WITH ROHS.  
 2. PRODUCT PERFORMANCE:  
 2.1 RATED VOLTAGE(MAX.):30V AC/DC  
 2.2 RATED CURRENT(MAX.):(2、3、4PIN)1.0A (1、5PIN)1.8A AC/DC  
 2.3 DIELECTRIC STRENGTH:100V AC FOR 1 MINUTE BETWEEN ADJACENT TERMINAL, NO BREAKDOWN  
 2.4 INSULATION RESISTANCE:1000 MΩ MIN. 100VDC FOR 1 MINUTE BETWEEN ADJACENT TERMINAL  
 2.5 CONTACT RESISTANCE:30 mΩ MAX.  
 2.6 OPERATING TEMPERATURE:-30°C to +85°C  
 3.PART NO. LEGEND: 1U206-345005-0000X

WATER CODE:SEE NOTES

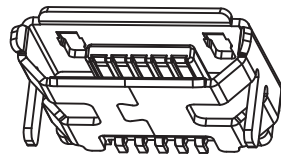

3D VIEW

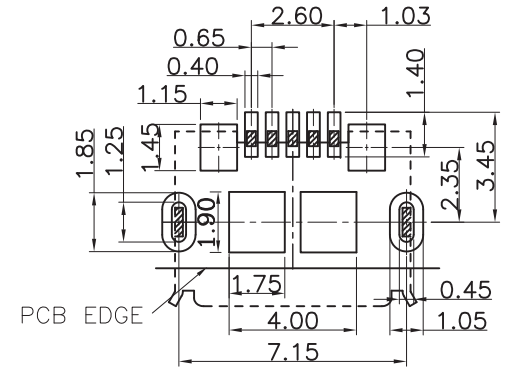
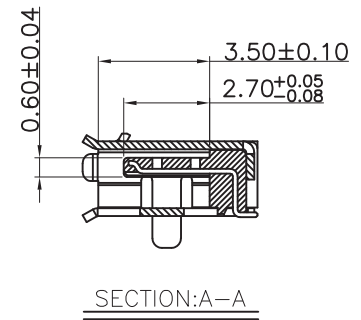
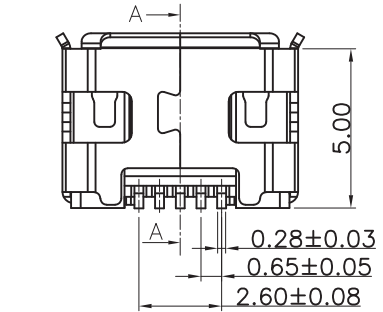
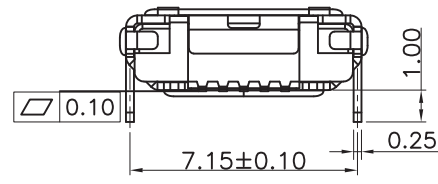
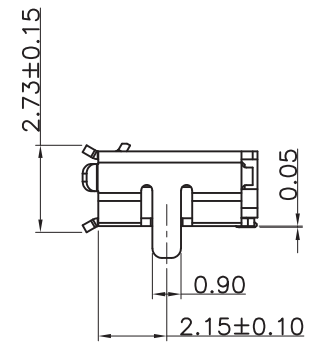
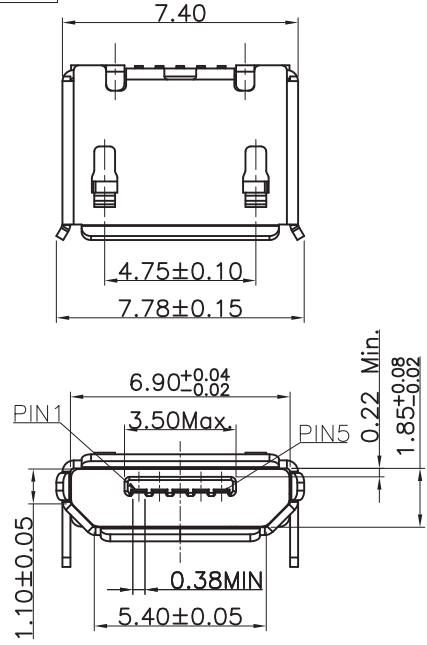

RECOMMENDED PCB LAYOUT

WATER CODE	NOTES
00024	SURFACE PLATING Au GF
00025	SURFACE PLATING Au 10u"
00026	SURFACE PLATING Au 15u"
00027	SURFACE PLATING Au 30u"

8.0	22.05.06	MODIFY PRODUCT NUMBER	ShunMingWen
7.0			
6.0			
5.0			
4.0			
NO.	DATE	DESCRIPTION	DRAWING

DRAWING:	GENERAL TOLERANCE	
Bains	.X: =±0.30	.X': =±2'
CHECKED:	.XX: =±0.20	.XX': =±1'
Tian Hai	.XXX: =±0.10	.XXX': =±0.5'
APPROVAL:	UNIT: MM	PROJECTION:
Cykin	SCALE: 1/1	
	SHEET: 1/1	



DESCRIPTION: Micro USB 5PIN B TYPE	
PART NO: 1U206-345005-000XX	REV: 8.0
OLD CODE: U6F05E-CXT2-B9	
DRAWING NO: UK0020	SIZE: A4