

DESCRIPTION

The MBR30200CT is a 30A schottky barrier rectifier, it uses our advanced technology to provide the customers with high surge capability, high efficiency, high current capability, low power loss and low forward voltage drop, etc.

The MBR30200CT is suitable for free wheeling and polarity protection, etc.

FEATURE

- *Schottky Barrier Chip
- *Guard Ring Die Construction for Transient Protection
- *High Current Capability and Low Forward Voltage Drop



ABSOLUTE MAXIMUM RATINGS(TA=25°C, unless otherwise specified.)

SYMBOL	PARAMETER	VALUE	UNIT
VRRM	Peak repetitive reverse voltage	200	V
VRWM	Working peak reverse voltage		V
VR	DC blocking voltage		V
VR(RMS)	RMS reverse voltage	140	V
IO	Average rectified output current	30 (15*2)	A
IFSM	Non-Repetitive peak forward surge current(8.3ms half sine wave)	200*2	A
Tj	Junction temperature	175	°C
Tstg	Storage temperature	-55~+150	°C
RθJA	Thermal Resistance from Junction to Ambient	62.5	°C/W
RθJC	Thermal Resistance From Junction To Case	3	°C/W

Notes: Absolute maximum ratings are those values beyond which the device could be permanently damaged. Absolute maximum ratings are stress ratings only and functional device operation is not implied.

■ ELECTRICAL CHARACTERISTICS (TA=25°C, unless otherwise specified)

PARAMETER	SYMBOL	TEST CONDITIONS	MIN	TYP	MAX	UNIT
Reverse Voltage	$V_{(BR)R}$	$I_R=0.10\text{mA}$	200			V
Reverse current	I_R	$V_R=200\text{V}$	$T_j=25^\circ\text{C}$	5.0	100	μA
			$T_j=125^\circ\text{C}$	5.0		mA
Forward voltage	V_F	$I_F=10\text{A}$	$T_j=25^\circ\text{C}$	0.832	0.88	V
			$T_j=125^\circ\text{C}$	0.71		V
		$I_F=15\text{A}$	$T_j=25^\circ\text{C}$	0.87	0.95	V
			$T_j=125^\circ\text{C}$	0.75		V

Notes: 1. Pulse Test: Pulse Width=300 μs , Duty Cycles \leq 2.0%.

■ TYPICAL CHARACTERISTICS

FIG.1: FORWARD CURRENT DERATING CURVE

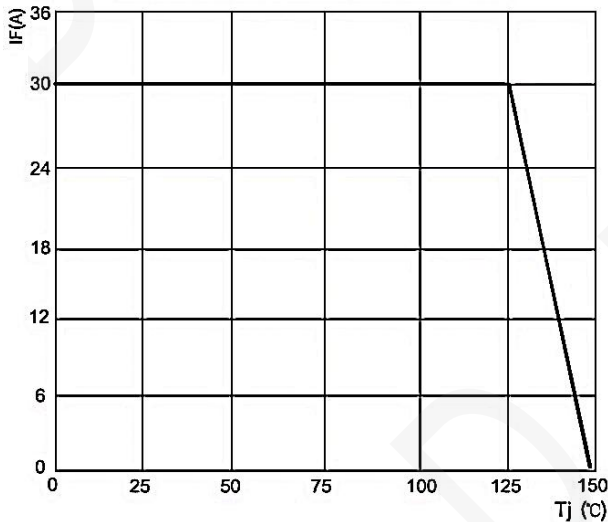

FIG.2: TYPICAL FORWARD CHARACTERISTICS

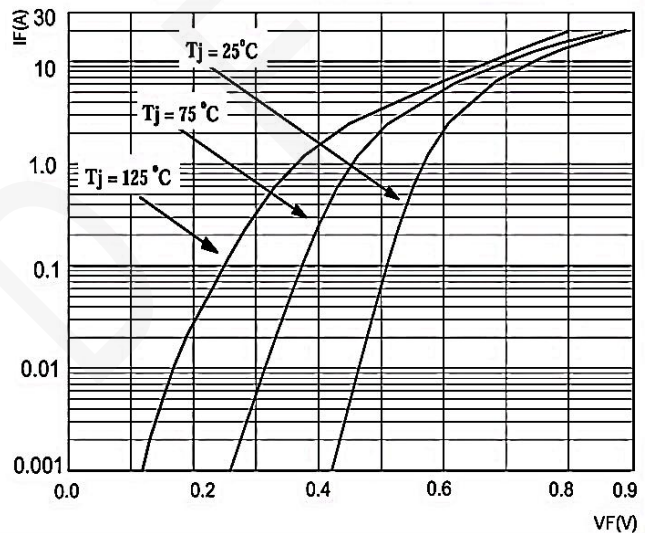

FIG.3: TOTAL CAPACITANCE DERATING CURVE

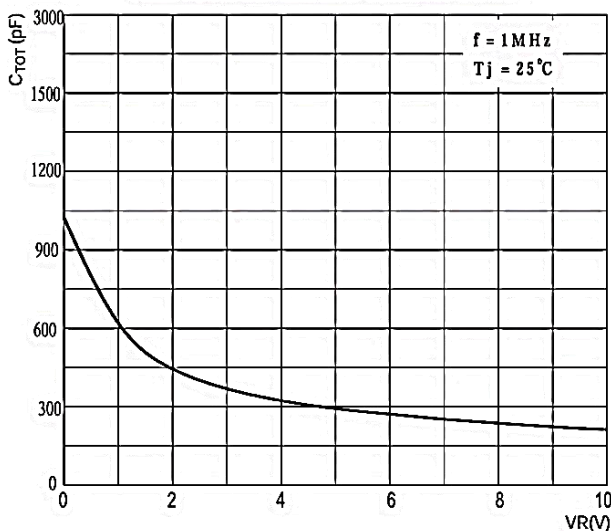
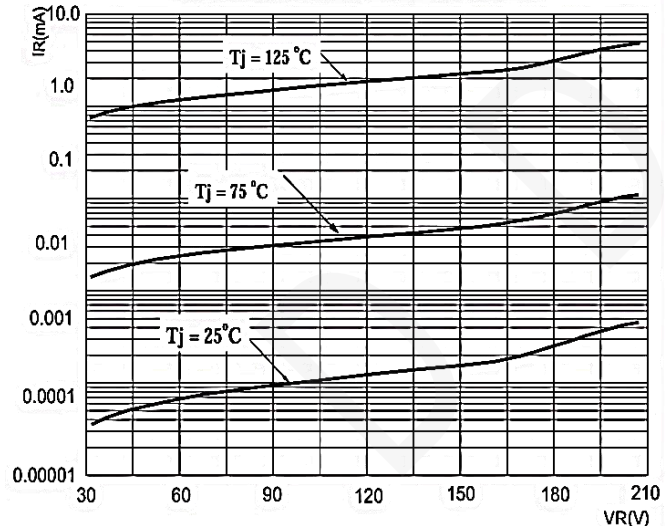
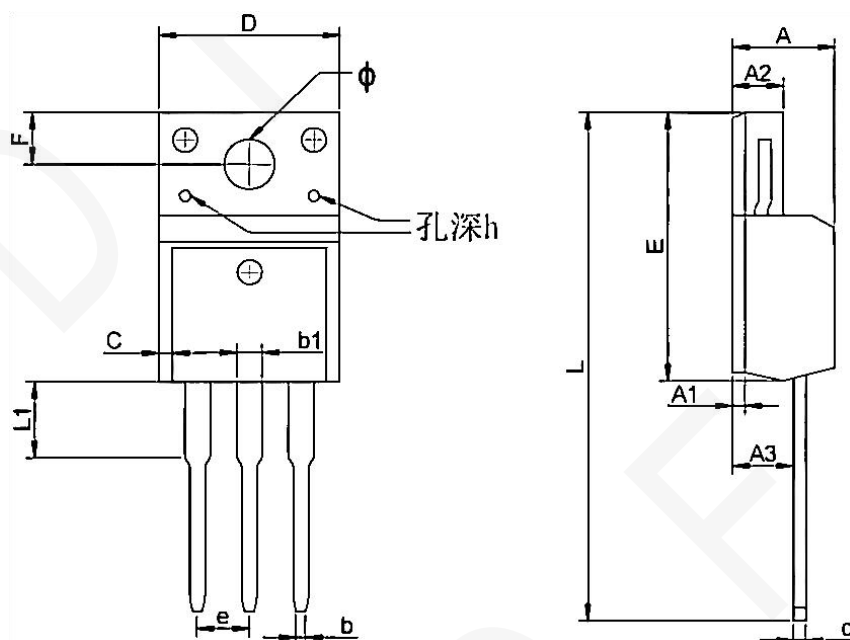

FIG.4: TYPICAL REVERSE CHARACTERISTICS



TO-220F PACKAGE OUTLINE DIMENSIONS

Symbol	Dimensions In Millimeters		Dimensions In Inches	
	Min.	Max	Min	Max
A	4.300	4.750	0.169	0.185
A1	1.830 REF		0.072 REF	
A2	2.300	2.850	0.090	0.112
A3	2.500	2.900	0.098	0.114
b	0.400	0.420	0.016	0.016
b1	1.220	1.280	0.048	0.050
C	0.690	0.720	0.027	0.028
c	0.490	0.510	0.019	0.020
D	9.960	10.200	0.392	0.400
E	15.000	15.950	0.588	0.625
e	2.574 TYP		0.101 TYP	
F	3.470 REF		0.136 REF	
y	3.200 REF		0.125 REF	
h	0.000	0.300	0.000	0.012
L	28.780	28.900	1.128	1.133
L1	2.990	3.100	0.117	0.122