

修订	标记	修改摘要	签名	日期
REV	MARK	REVISION DESCRIPTION	SIGNATURE	DATE
AO		NEW DWG		2016-03-12

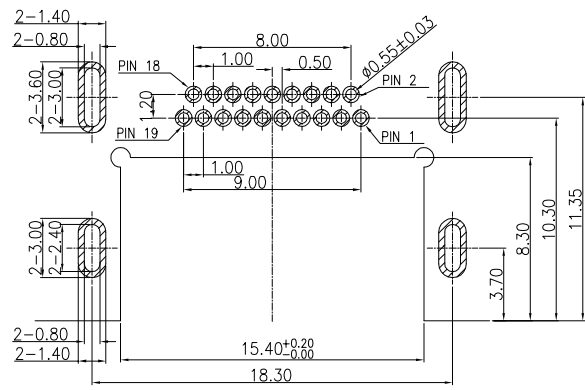

TOLERANCE: ±0.05  
RECOMMENDED PCB LAYOUT  
(TOP VIEW)

- NOTES:  
 1.ELECTRONIC:  
 CONTACT RESISTANCE: 30mohm MAX  
 INSULATION RESISTANCE: 100 Mohm MIN  
 WITHSTAND VOLTAGE:AC 500V,1min.  
 2.MECHANICAL:  
 DURABILITY: 5000 CYCLE.  
 3.ENVIRONMENT CHARACTERISTICS:  
 OPERTING TEMPERATURE:-55°C TO +105°C  
 4.RECOMMANDER PCB THICKNESS 1.2

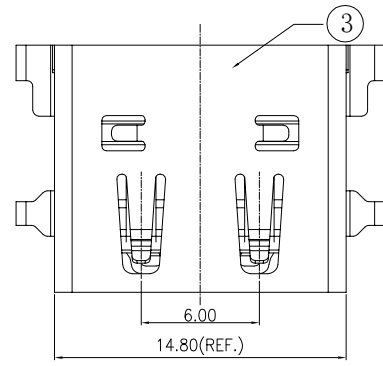
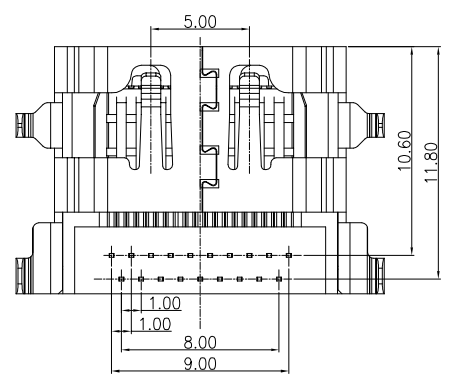
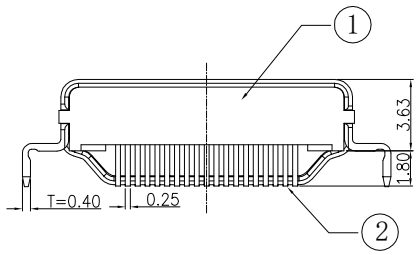
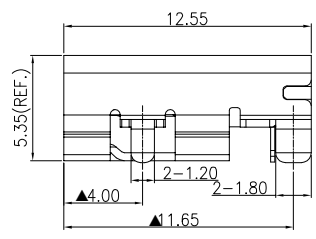
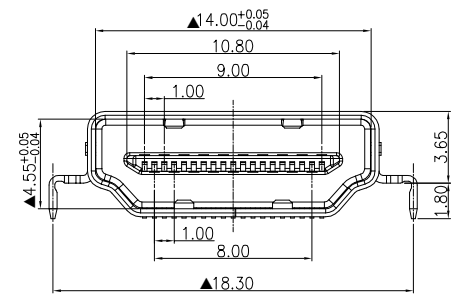

3	SHELL	1	STAINLESS STEEL SUS304 T=0MMO PLATED
2	CONTACT	19	COPPER ALLOY C2680 T=0.20 AU/TIN PLATED
1	HOUSING	1	THERMOPLASTIC (UL 94V-0) BLACK
No.	PART NAME	QTY	REMARK

深圳市华德共创科技有限公司  
Shenzhen Huade co-create Technology Co.,LTD  
电话: 0755-27111216 传真: 0755-29940187

-TOLERANCES- UNLESS OTHERWISE SPECIFIED 公差参数表		TITLE: 产品名称: HDMI AF正向沉板不锈钢镀镍黑胶3.65	
X.X	±0.30	X.X*	±3°
X.XX	±0.20	X.XX*	±2°
X.XXX	±0.10	X.XXX*	±1°

APPD: 核准:	王建业	PART NO: 产品编号:	HDMI-GD-111PWB		
CHECK: 校对:	黄艳兰	DATE	SCALE	UNIT	CODE NUMBER
DRAW: 绘图:	2016-03-12	1:1	mm	A001	