

# 规格承认书

## Specification For Approval

产品名称 Product	塑料外壳双面金属化聚丙烯膜电容器 Double sided metallized polypropylene film capacitor (Box-type)
部品型号 Type &Spec.	C82 (MMKP82)
文件编号 File No.	WSCRS-2025040359
客 户 Customer	深圳市立创电子商务有限公司
客户料号 Material Code	C46638900
日 期 Date	2025.4.3

供方确认 Supplier confirmation	客户确认 Customer Approval
	

请于承认后签章回执一份  
Please sign for approval and reply



无锡万盛电子有限公司  
WUXI WALSON ELECTRONICS CO., LTD.

地址：江苏省江阴市长泾镇兴业路 22 号 电话 Tel.: +86-510-88719928  
Addr.: No.22, Xingye RD, Changjing Town, Jiangyin City, Jiangsu, China  
E-Mail: walson@walson-elec.com Website: www.walson-elec.com



1. 证书信息 Certification

序号 No.	检测项目 Test Item	证书/报告编号 Certification/Report No.	检测型号/对象 Type	备注 Notes
1	RoHS	A2240229988102E	薄膜电容器 Metallized Film Capacitor	证书到期后, 以最新的为准 After the certificate expires, the latest one shall prevail
2	REACH	A2240229988103E	薄膜电容器 Metallized Film Capacitor	

2. 结构 Construction

本产品由金属化高温聚丙烯膜卷绕而成, 端面喷涂无铅金属并焊接引线, 外部用阻燃塑壳和阻燃环氧树脂封装。

This product is winding by metallized high-temperature polypropylene film. Both end faces of the core sprayed with lead-free metal and welded with leads. The exterior is packaged with flame-retardant plastic shell and flame-retardant epoxy resin.

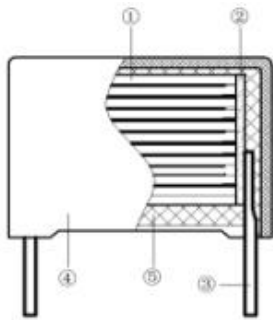

- ① 芯子 Core
- ② 喷金层 Spray Metal Layer
- ③ 引出线 Lead Wire
- ④ 阻燃塑壳 Flame-retardant Plastic Case
- ⑤ 环氧树脂 Epoxy Resin

☆ 芯子结构图 Structural Diagram

序号 No.	材料 Material
①	金属化高温聚丙烯膜 Metallized High-Temperature Polypropylene Film
②	双面金属化聚酯膜 Single Margin PET film with doubleside metallized
③	耐高温聚丙烯膜 High-Temperature Polypropylene film

3. 外形尺寸 Dimensions

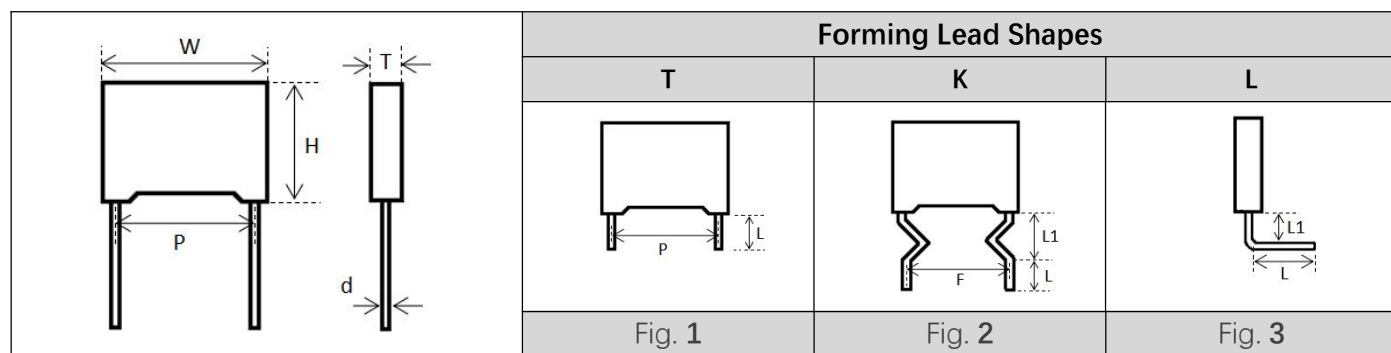

(单位 Dimension: mm)

客户料号 Customer P/N	规格型号 & 料号 Specifications & Walson P/N	W*H*T ±1.0	P ±0.5	F ±0.5	d ±0.1	L1 Max	L ±0.5	Fig	MPQ (Pcs)
C46638892	MMKP82-630V-822-P10 C822J822A7P40001	13*11*5	10	-	0.6	-	-	1	500
C46638893	MMKP82-630V-103-P10 C822J103A5P40001	13*11*5	10	-	0.6	-	-	1	500
C46638894	MMKP82-630V-473-P15 C823J473A4P60001	18*13.5*7.5	15	-	0.8	-	-	1	500
C46638895	MMKP82-1KV-103-P15 C823A103B0P60001	18*11*5	15	-	0.8	-	-	1	500
C46638896	MMKP82-1KV-153-P15 C823A153B0P60001	18*12*6	15	-	0.8	-	-	1	500
C46638897	MMKP82-1KV-223-P15 C823A223B0P60001	18*13.5*7.5	15	-	0.8	-	-	1	500
C46638898	MMKP82-1KV-273-P15 C823A273A9P60001	18*13.5*7.5	15	-	0.8	-	-	1	500
C46638899	MMKP82-1KV-333-P15 C823A33370P60001	18*14.5*8.5	15	-	0.8	-	-	1	500
C46638900	MMKP82-1KV-104-P15 C823A104A6P60002	18*19*11	15	-	0.8	-	-	1	500
C46638901	MMKP82-1KV-334K-P22.5 C823A334A7P90002	26.5*29.5*14.5	22.5	-	0.8	-	-	1	250

4. 产品编码说明 Part Number System

☆ 16 位产品代码说明 16 digit product code description

1	2	3	4	5	6	7	8	9	10	11	12	13	14	15	16
C	8	2													

第 1~3 位	型号代码 C82=MMKP82	Digit 1 to 3	Series Code C82=MMKP82
第 4~5 位	直流额定电压 2E=250V 2G=400V 2S=450V 2T=520V 2J=630V 3A=1000V	Digit 4 to 5	D.C. Rated Voltage 2E=250V 2G=400V 2S=450V 2T=520V 2J=630V 3A=1000V
第 6~8 位	标称容量 举例:103=10×10 <sup>3</sup> pF=0.01μF	Digit 6 to 8	Rated Capacitance value for example: 103=10×10 <sup>3</sup> pF=0.01μF
第 9~10 位	内部代码	Digit 9 to 10	Internal Use
第 11 位	成型方式	Digit 11	Forming
第 12 位	引线脚距 3=7.5mm 4=10mm 6=15mm 8=20mm 9=22.5mm A=25mm	Digit 12	Lead pin pitch 3=7.5mm 4=10mm 6=15mm 8=20mm 9=22.5mm A=25mm
第 13~14 位	引线长度或编带 30=3.0mm 35=3.5mm BD=编带	Digit 13 to 14	Lead Length or Ammo-Pack 30=3mm 35=3.5mm BD=Ammo-Pack
第 15~16 位	内部代码	Digit 15 to 16	Internal Use

☆ 型号规格描述说明 (例) Description of specifications and models (example)

MMKP82	-	630V	-	104K	-	CT10*3.5
①		②		③		④

第 1 组	型号	Group 1	Series
第 2 组	直流额定电压	Group 2	D.C. Rated Voltage
第 3 组	标称容量与容量偏差	Group 3	Rated Capacitance value & tolerance
第 4 组	成型方式与脚距 长脚包装: P+脚距 例: P10 表示长脚, 脚距为 10mm, 无成型剪脚。  成型剪脚: 成型方式+脚距*引线长度 例: CT10*3.5 表示成型方式为 CT,成型后脚距为 10mm, 引线长度为 3.5mm。  编带电容为: 成型方式+脚距*编带 例: CT10*T 表示脚距为 10mm, 包装方式为直脚编带。	Group 4	Forming method and Lead pin pitch Standard: P+ pitch e.g. P10 indicates general lead, pitch=10 mm, no lead shape shearing.  Forming: Forming shape+pitch*insertion depth e.g. CT 10*3.5 indicates CT forming, pitch=10 mm, and the lead length=3.5 mm.  Taping: Forming pitch*Taping e.g. CT10*T indicates the pitch=10 mm with ammo-packing.

## 5. 特点及主要用途 Application and Feature

## ☆ 主要用途

- 广泛应用于高压高频脉冲电路中
- 吸收和 SCR 整流电路

## ☆ Application

- Widely used in high voltage, high frequency and pulse circuit
- SNUBBER and SCR rectifier circuit

## ☆ 特点

- 双面金属化聚丙烯膜
- 损耗小, 内部温升小
- 负电容量温度系数
- 优异的阻燃性能

## ☆ Characteristics

- Double sided metallized polypropylene film
- Low loss and small inherent temperature rise
- Negative temperature coefficient of capacitance
- Excellent active and passive flame resistant abilities

## ☆ 技术要求 Specifications

引用标准 Reference Standard	GB/T 10190-2012 (IEC 60384-16)	
工作温度范围 Operating Temperature Range	-40 °C ~ +105 °C	
额定温度 Rated Temperature	85 °C (+85 °C to +105 °C decreasing factor 1.25 % per °C for $U_R$ )	
额定电压 Rated Voltage	250/400/450V/630/1000/1600 /2000 VDC	
电容量范围 Capacitance Range	0.001 $\mu$ F ~ 3.3 $\mu$ F	
电容量偏差 Capacitance Tolerance	$\pm 5\%$ (J)、 $\pm 10\%$ (K)	(20 °C, 1 kHz, 1 V)
耐电压 Voltage Proof	1.6 $U_R$	(20 °C, 5 s)
损耗角正切值 Dissipation Factor	$\leq 0.0010$ $C_R < 1.0 \mu$ F $\leq 0.0020$ $C_R \geq 1.0 \mu$ F	(20°C, 1 kHz, 1 V)
绝缘电阻 Insulation Resistance	$\geq 25000 M\Omega$ $C_R \leq 0.33 \mu$ F $\geq 7500 s$ $C_R > 0.33 \mu$ F	(20 °C, 100 V, 1 min)

6. 可靠性测试 Reliability Test

序号 No.	测试项目 Test Item	测试方法 Test method	要求 Requirement
1	外部检查 Outline check	目视检查, 卡尺测量 Visual inspection and caliper measurement	外形规整, 无可见损伤; 标志端正、清晰、无误 The appearance is regular without visible damage; The mark is regular, clear and correct.
	初始测量 Initial measurement	电容量 C: 20 °C, 1 kHz, 1 V 损耗角正切 Tan δ: 20 °C, 1 kHz, 1 V	
	引出端 强度 Terminal Strength	拉力 Pull 拉力: 5 N 方向: 180 ° 时间: 10±1 s Pull: 5 N Direction: 180 ° Time: 10±1 s	无可见损伤 No visible damage
		弯曲 The pull of bend 拉力: 2.5 N 方向: 90 ° 次数: 2 次 The pull of bend: 2.5 N Direction: 90 ° Times: 2	无可见损伤 No visible damage
	耐焊接热 Soldering Heat Resistance	焊槽温度: +260 °C±5 °C 浸入时间: 10 s±1 s 浸入深度离安装面 2+0/-0.5 mm, 采用厚度为 1.5 mm±0.5 mm 的绝热屏蔽板 Solder temperature: 260 °C±5 °C Immersion time: 10 s±1 s Immersion depth is 2+0/-0.5mm away from the installation surface, and insulation shielding plate with a thickness of 1.5mm ± 0.5mm is used	无可见损伤 No visible damage
	最后测量 Final measurement		无可见损伤 容量变化:   ΔC/C   ≤ 3 % 损耗变化: ΔTan δ ≤ 0.004 (1 kHz) No visible damage   ΔC/C   ≤ 3 % ΔTan δ ≤ 0.004 (1 kHz)
2	初始测量 Initial measurement	电容量 C: 20 °C, 1 kHz, 1V 损耗角正切 Tan δ: 20 °C, 1 kHz, 1 V	
	可焊性 Solderability	焊槽温度: 235 °C±5°C 浸入时间: 2.0 s±0.5 s Solder temperature: 235 °C ±5 °C Immersion time: 2.0 s±0.5 s	引线表面浸锡良好, 焊层面积达 95 % 以上 The surface of the lead wire is well tinned, and the welding layer area reaches over 95 %

序号 No.	测试项目 Test Item	测试方法 Test method	要求 Requirement	
2	温度快速变化 Rapid Change of Temperature	$\theta A = -40\text{ }^{\circ}\text{C}$ $\theta B = +105\text{ }^{\circ}\text{C}$ 循环次数: 5 次, 持续时间 $t = 30\text{ min}$  $\theta A = -40\text{ }^{\circ}\text{C}$ $\theta B = +105\text{ }^{\circ}\text{C}$ 5 cycles Duration: $t = 30\text{ min}$	无可见损伤  No visible damage	
	振动 Vibration	频率范围: 10--500 Hz 振幅 : 0.75 mm 试验安装方向: X, Y, Z. 试验每个方向持续时间 : 2 h  Frequency range: 10 Hz to 500 Hz Amplitude: 0.75 mm Test installation direction: X,Y,Z, Test duration in each direction: 2 h	无可见损伤  No visible damage	
	碰撞 Bump	碰撞次数: 4000 次 加速度: 390 m/S <sup>2</sup> 脉冲持续时间: 6 ms  Times of collisions: 4000 times Acceleration: 390 m/s <sup>2</sup> Pulse duration: 6 ms	无可见损伤  No visible damage	
	最后测量 Final measurement		无可见损伤 容量变化: $ \Delta C/C  \leq 3\%$ 损耗变化: $\Delta \tan \delta \leq 0.004$ (1 kHz) 绝缘电阻: $\geq$ 初始测量值的 50 %  No visible damage $ \Delta C/C  \leq 3\%$ $\Delta \tan \delta \leq 0.004$ (1 kHz) I.R. $\geq 50\%$ of the rated value	
3	气候顺序 Climate Sequence	干热 Dry Heat	+105 °C, 16 h	
		循环湿热 Damp Heat Cyclic	湿热试验 Db, 严酷度 b 第一次循环  Test Db, Severity: b, the first cycle	
		寒冷 Cold	-40 °C, 2 h	
		循环湿热 Damp Heat Cyclic	试验 Db, 严酷度 b 其余循环  Test Db, Severity b, the other cycles,	
	最后测量 Final Measurement		外观无可见损伤, 标志清晰 电容量变化: $ \Delta C/C  \leq 5\%$ , 损耗角正切的增加: $\Delta \tan \delta \leq 0.005$ (1 kHz) 绝缘电阻: $\geq$ 额定值的 50 %  There shall be no evidence of deterioration and the marking shall be legible. $ \Delta C/C  \leq \pm 5\%$ Increase of $\tan \delta \leq 0.005$ (1 kHz) I.R. $\geq 50\%$ of the rated value	

序号 No.	测试项目 Test Item	测试方法 Test method	要求 Requirement
4	初始测量 Initial measurement	电容量 C: 20 °C, 1 kHz, 1V 损耗角正切 Tan δ: 20 °C, 1 kHz, 1V	
	稳态湿热 Damp Heat Steady State	温度: +40 °C±2 °C 相对湿度: 93 %±2 %RH 试验周期: 21 天 Temperature:+40 °C±2 °C Humidity:93 %±2 %RH Duration:21 Days	无可见损伤 No visible damage
	最后测量 Final measurement		容量变化   ΔC/C   ≤ 5 % 损耗变化 ΔTan δ ≤ 0.002 (1 kHz) 绝缘电阻 I.R. ≥ 初始测量值的 50 %    ΔC/C   ≤ 5 % ΔTan δ ≤ 0.002 (1 kHz) I.R. ≥ 50 % of the rated value
5	初始测量 Initial measurement	电容量 C: 20 °C, 1 kHz, 1V 损耗角正切 Tan δ: 20 °C, 1 kHz, 1V	
	耐久性 Endurance	温度: +85 °C±2 °C 试验周期: 1000 小时 施加电压: 1.25 U <sub>R</sub> Temperature: +85 °C±2 °C Duration: 1000 (h) Test voltage:1.25 U <sub>R</sub>	无可见损伤, 标志清晰 No visible damage
	最后测量 Final measurement		容量变化:   ΔC/C   ≤ 5 % 损耗变化: ΔTan δ ≤ 0.004 (1 kHz) 绝缘电阻: ≥ 初始测量值的 50 %    ΔC/C   ≤ 5 % ΔTan δ ≤ 0.004 (1 kHz) I.R. ≥ 50 % of the rated value
6	随温度而定的特性 Temperature Characteristic	静态法, 电容器依次保持在下述每个温度: Static method, the capacitor is maintained at each of the following temperatures in sequence:  b: (20±2) °C, d: (-40±2) °C, f: (105±2) °C	在 b,d,f 点上进行电容量测量 在下限类别温度(-40 °C)时的特性: Measure capacitance at points b, d, and f, Characteristics at lower limit temperature (-40 °C): 0 ≤ ΔC/C ≤ +3.0 %  在上限类别温度(105 °C)时的特性: Characteristics at upper limit category temperature (105 °C): -4.25 % ≤ ΔC/C ≤ 0

序号 No.	测试项目 Test Item	测试方法 Test method	要求 Requirement
7	初始测量 Initial measurement	电容量 C: 20 °C, 1 kHz, 1V 损耗角正切 Tan δ: 20 °C, 1 kHz, 1V	
	充电和放电 Charging and Discharging	充电次数: 10000 次 充电电压: $1.0 U_R$ 充电时间: 0.5 s 放电时间: 0.5 s 充电电阻: $220/C_R \Omega$ 放电电阻: $R=10/C_R$ 或 $20 \Omega$ 取较大者 ( $C_R$ : 额定电容量, 单位 $\mu F$ )  Times: 10000 Charging voltage: $1.0 U_R$ Duration of charging: 0.5 s Duration of discharging: 0.5 s Charging resistance: $220/C_R (\Omega)$ or current intensity $\leq 1 A$ (whichever is the less current intensity) Discharging resistance: $R=U_R/(C_R \times dv/dt)$ $C_R$ : rated capacitance ( $\mu F$ )	
	最后测量 Final measurement		容量变化: $ \Delta C/C  \leq 5\%$ 损耗变化: $\Delta \tan \delta \leq 0.005 (1 \text{ kHz})$ 绝缘电阻: $\geq$ 初始测量值的 50 %  $ \Delta C/C  \leq 5\%$ $\Delta \tan \delta \leq 0.005 (1 \text{ kHz})$ I.R. $\geq 50\%$ of the rated value

7. 产品特性曲线图 Graphs of Product Characteristics

☆ 温度特性曲线 Temperature Characteristic Curve

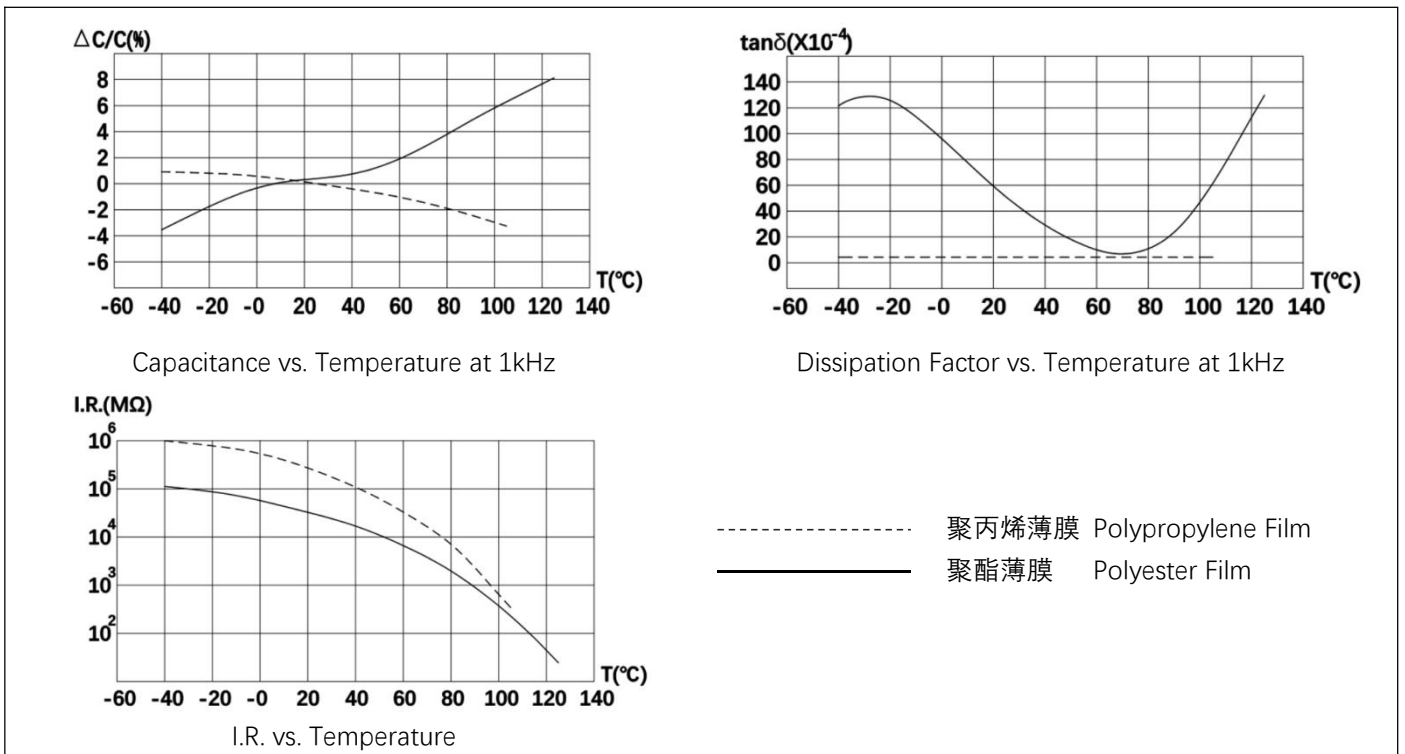

☆ 频率特性曲线 Frequency Characteristic Curve

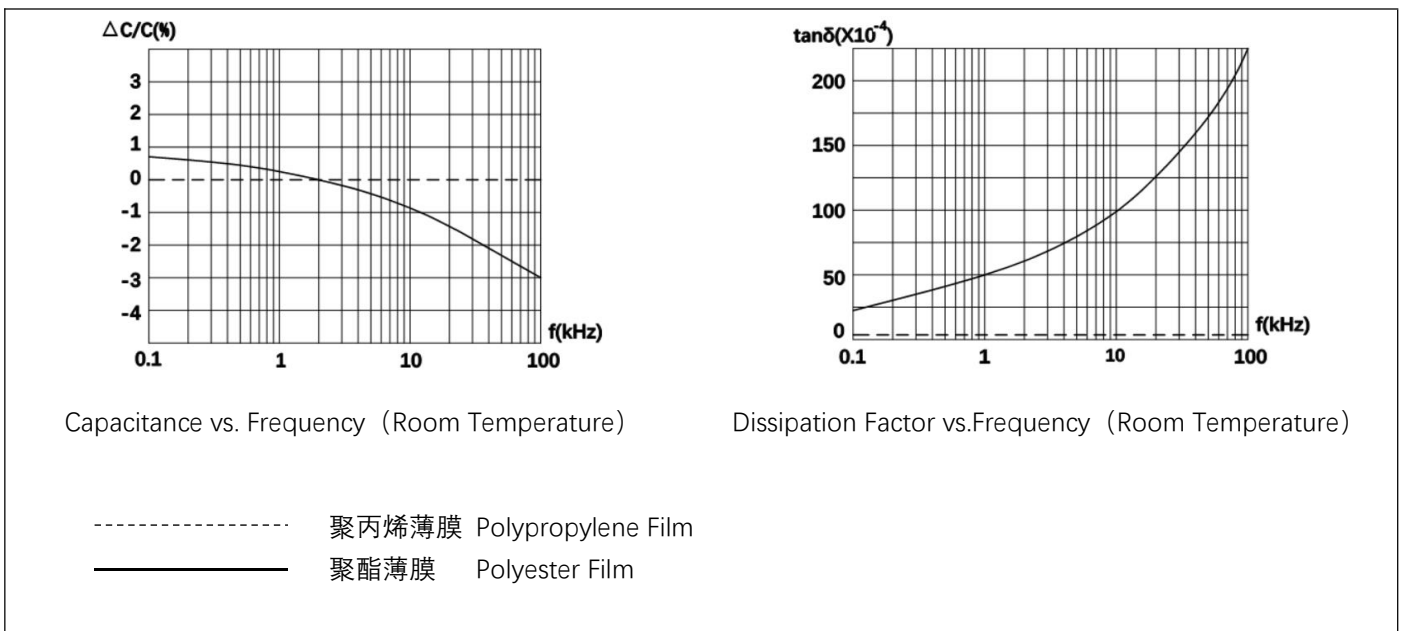

8. 焊接 Weld

焊接电容器时，热量会对电容器的引线和包封层产生影响，并且高温，以及长时间焊接都会对电容器的性能造成影响，甚至导致失效。

When welding, heat can have an impact on the leads and packaging layer of the capacitor, and high temperature and prolonged welding can affect the performance of the capacitor, even leading to failure.

焊接条件按下面的焊接图表：

The welding conditions are shown in the following welding chart

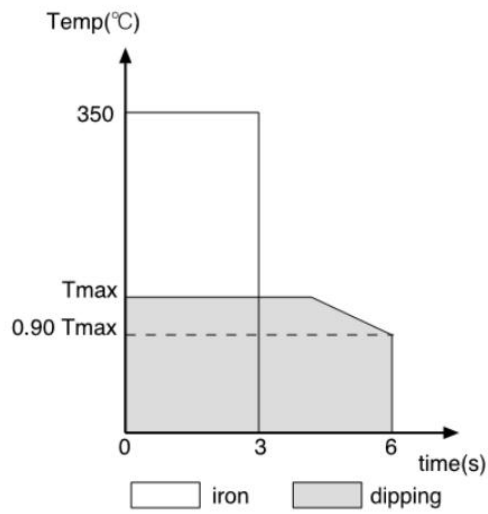

	Tmax	Time	Note
Pre-heating	110°C	1min	
	100°C	1min	OPP ≤ 7.5
Soldering	270°C	4s	
	260°C	4s	OPP ≤ 7.5

### 9. 产品出厂检验 OQC

检查项目 (每批) Tested Items	检查报告 Test Level (IEC410)	
	IL	AQL
1 外观检查 Appearance Check 2 外形尺寸 Dimension	S-4	1 %
1 电容量 Capacitance 2 损耗角正切 Dimension 3 耐电压 Voltage Withstand 4 绝缘电阻 Insulation Resistance	II	0.065 %
1 可焊性 Weld-ability	S-3	2.5 %

### 10. 储存条件 Storage Conditions

环境温度: -10 °C ~ +40 °C

相对湿度: 不大于 85 %

气 压: 40—106 KPA

Environmental Temperature: -10 °C ~ +40 °C

Relative Humidity: ≤85 % at 40 °C

Atmospheric Pressure: 40-106 KPA

应在无酸性碱性或其它腐蚀气体的库房内贮存, 且不允许阳光直射, 包装成箱的产品的贮存期为二年。产品拆封后应在不超过三个月内使用, 避免因暴露而致引脚氧化锈蚀。

Should be stored in a warehouse without acidic, alkaline or other corrosive gases, and direct sunlight is not allowed. The storage period of packaged products is two years. After the product is unpacked, it should be used for no more than three months to avoid pin oxidation and corrosion caused by exposure.

### 11. 包装 Packaging

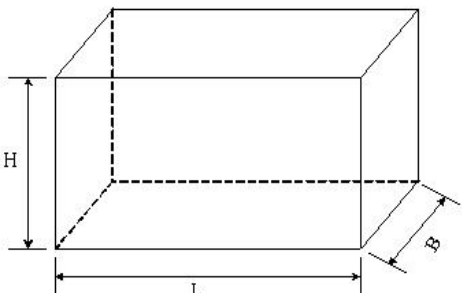
	类型 types of	L <sub>(cm)</sub>	B <sub>(cm)</sub>	H <sub>(cm)</sub>
	标准外箱 Standard outer box		44	26
		50	29	25
		52	35	27.5
标准内箱 Standard inner box		24.5	21	17.5
		27	23.5	23
		34.5	25.5	4.8

注: 部分情况下包装箱尺寸与上表尺寸略有差异

Note: Packaging may differ from the dimensions in the table above in some cases.