



AiP28180/28181/48180/48181 Zero-Drift, Bidirectional Current Detection Amplifier

Product Specification

Specification Revision History:

Version	Date	Description
2025-08-A0	2025-08	New
2025-09-A1	2025-09	Modify parameters
2025-11-A2	2025-11	Delete DFN10, DFN8 package form; delete AiPx8180B
2025-12-A3	2025-12	Update marking code



Contents

1、 General Description.....	1
2、 Block Diagram And Pin Description	4
2.1、 Block Diagram	4
2.2、 Pin Configurations (AiP28181, AiP48181).....	5
2.3、 Pin Description (AiP28181, AiP48181).....	5
2.4、 Pin Configurations (AiP28180, AiP48180).....	6
2.5、 Pin Description (AiP28180, AiP48180).....	6
3、 Electrical Parameter	7
3.1、 Absolute Maximum Ratings.....	7
3.2、 ESD	7
3.3、 Recommended Operating Conditions.....	7
3.4、 Electrical Characteristics	7
4、 Characteristic Curve	9
5、 Typical Application Circuit And Application Note.....	10
6、 Package Information	11
6.1、 MSOP8.....	11
6.2、 MSOP10.....	12
6.3、 TSSOP14.....	13
6.4、 TSSOP20.....	14
7、 Statements And Notes	15
7.1、 The name and content of Hazardous substances or Elements in the product.....	15
7.2、 Notes	15



1、General Description

AiPx8181 and AiPx8180 are multi-channel, wide-bandwidth, zero-drift current detection amplifiers, mainly used in battery monitoring, power management, over-current detection and other applications. This current can sense the voltage drop across the shunt resistor at a common-mode voltage ranging from -0.2V to 30V. The AiPx8181 and AiPx8180 integrate a matched resistor gain network, with four fixed gain options: 20V/V, 50V/V, 100V/V and 200 V/V.

AiPx8181 and AiPx8180 are powered by a single power supply with a voltage range of 2.7V to 5.5V. The dual-channel AiP28181 and AiP28180 have a maximum supply current consumption of 500uA, while the four-channel AiP48181 and AiP48180 have a maximum supply current consumption of 900uA. AiPx8181 is available in dual-channel MSOP10 and four-channel TSSOP20 packages; AiPx8180 is available in dual-channel MSOP8 and four-channel TSSOP14 packages.

Features:

- Rail-to-rail output
- Offset voltage:
 - ◆ $\pm 150\mu\text{V}$ (Max.), $V_{\text{CM}}=0\text{V}$
 - ◆ $\pm 500\mu\text{V}$ (Max.), $V_{\text{CM}}=12\text{V}$
- Precision and zero-drift characteristics
 - ◆ Gain error: $\pm 1\%$ (Max.)
 - ◆ Offset drift: $1\mu\text{V}/^{\circ}\text{C}$ (Max.)
 - ◆ Gain drift: $20\text{ppm}/^{\circ}\text{C}$ (Max.)
- Output voltage gain:
 - ◆ 20V/V (AiPx8181 A1, AiPx8180 A1)
 - ◆ 50V/V (AiPx8181 A2, AiPx8180 A2)
 - ◆ 100V/V (AiPx8181 A3, AiPx8180 A3)
 - ◆ 200V/V (AiPx8181 A4, AiPx8180 A4)
- High bandwidth: 350kHz (AiPx8181 A1, AiPx8180 A1)
- Package form:
 - ◆ AiP28180: MSOP8
 - ◆ AiP28181: MSOP10
 - ◆ AiP48180: TSSOP14
 - ◆ AiP48181: TSSOP20



Ordering Information:

Reel packing specifications:

Part number	Packaging form	Marking code	Reel quantity	Boxed reel quantity	Notes
AiP28180A1MA8.TR	MSOP8	28180A1	5000 PCS/reel	10000 PCS/box	Dimensions of plastic enclosure: 3.0mm×3.0mm Pin spacing: 0.65mm
AiP28180A2MA8.TR	MSOP8	28180A2	5000 PCS/reel	10000 PCS/box	Dimensions of plastic enclosure: 3.0mm×3.0mm Pin spacing: 0.65mm
AiP28180A3MA8.TR	MSOP8	28180A3	5000 PCS/reel	10000 PCS/box	Dimensions of plastic enclosure: 3.0mm×3.0mm Pin spacing: 0.65mm
AiP28180A4MA8.TR	MSOP8	28180A4	5000 PCS/reel	10000 PCS/box	Dimensions of plastic enclosure: 3.0mm×3.0mm Pin spacing: 0.65mm
AiP28181A1MA10.TR	MSOP10	28181A1	5000 PCS/reel	10000 PCS/box	Dimensions of plastic enclosure: 3.0mm×3.0mm Pin spacing: 0.50mm
AiP28181A2MA10.TR	MSOP10	28181A2	5000 PCS/reel	10000 PCS/box	Dimensions of plastic enclosure: 3.0mm×3.0mm Pin spacing: 0.50mm
AiP28181A3MA10.TR	MSOP10	28181A3	5000 PCS/reel	10000 PCS/box	Dimensions of plastic enclosure: 3.0mm×3.0mm Pin spacing: 0.50mm
AiP28181A4MA10.TR	MSOP10	28181A4	5000 PCS/reel	10000 PCS/box	Dimensions of plastic enclosure: 3.0mm×3.0mm Pin spacing: 0.50mm
AiP48180A1TA14.TR	TSSOP14	48180A1	5000 PCS/reel	10000 PCS/box	Dimensions of plastic enclosure: 5.0mm×4.4mm Pin spacing: 0.65mm
AiP48180A2TA14.TR	TSSOP14	48180A2	5000 PCS/reel	10000 PCS/box	Dimensions of plastic enclosure: 5.0mm×4.4mm Pin spacing:



					0.65mm
AiP48180A3TA14.TR	TSSOP14	48180A3	5000 PCS/reel	10000 PCS/box	Dimensions of plastic enclosure: 5.0mm×4.4mm Pin spacing: 0.65mm
AiP48180A4TA14.TR	TSSOP14	48180A4	5000 PCS/reel	10000 PCS/box	Dimensions of plastic enclosure: 5.0mm×4.4mm Pin spacing: 0.65mm
AiP48181A1TA20.TR	TSSOP20	AiP48181A1	4000 PCS/ reel	8000 PCS/box	Dimensions of plastic enclosure: 6.5mm×4.4mm Pin spacing: 0.65mm
AiP48181A2TA20.TR	TSSOP20	AiP48181A2	4000 PCS/ reel	8000 PCS/box	Dimensions of plastic enclosure: 6.5mm×4.4mm Pin spacing: 0.65mm
AiP48181A3TA20.TR	TSSOP20	AiP48181A3	4000 PCS/ reel	8000 PCS/box	Dimensions of plastic enclosure: 6.5mm×4.4mm Pin spacing: 0.65mm
AiP48181A4TA20.TR	TSSOP20	AiP48181A4	4000 PCS/ reel	8000 PCS/box	Dimensions of plastic enclosure: 6.5mm×4.4mm Pin spacing: 0.65mm

Note: If the physical information is inconsistent with the ordering information, please refer to the actual product.



2、Block Diagram And Pin Description

2.1、Block Diagram

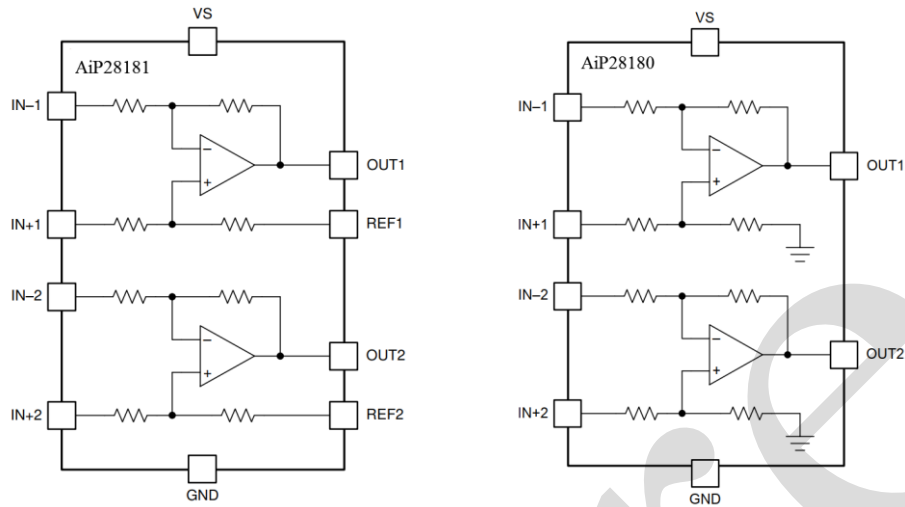

Figure 1. Function diagram of AiP28181 and AiP28180

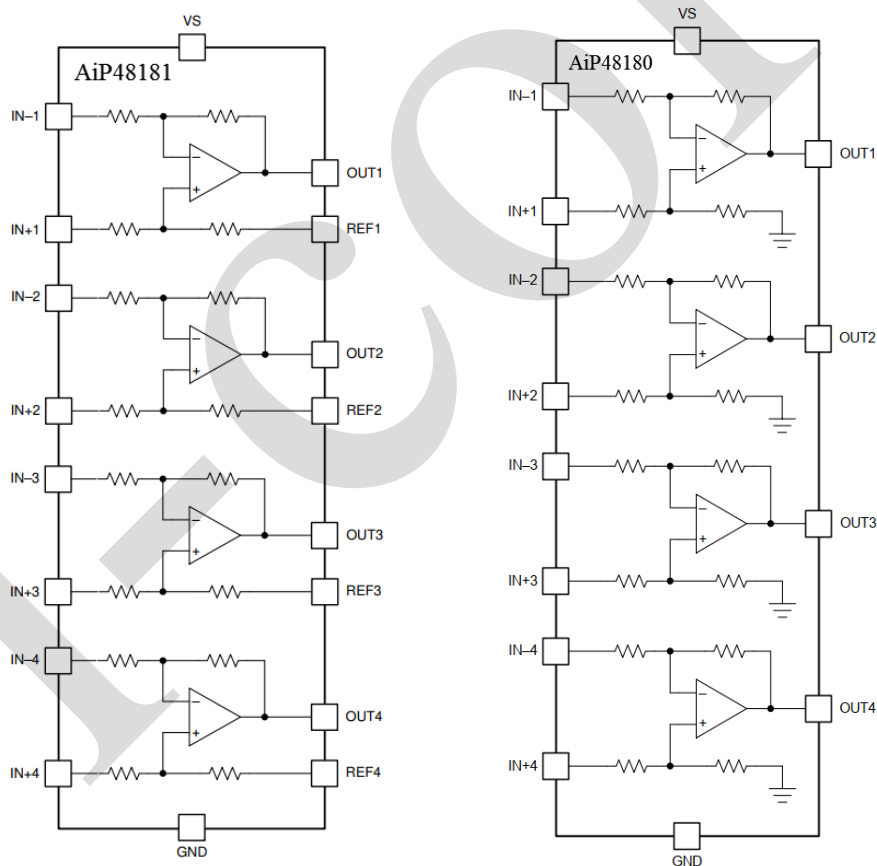

Figure 2. Function diagram of AiP48181 and AiP48180



2.2、Pin Configurations (AiP28181, AiP48181)

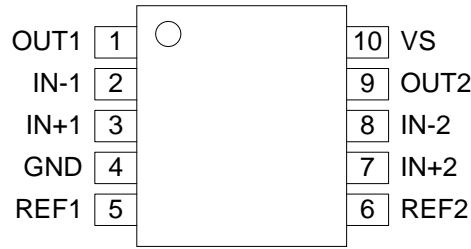

Figure 3. MSOP10 (AiP28181)

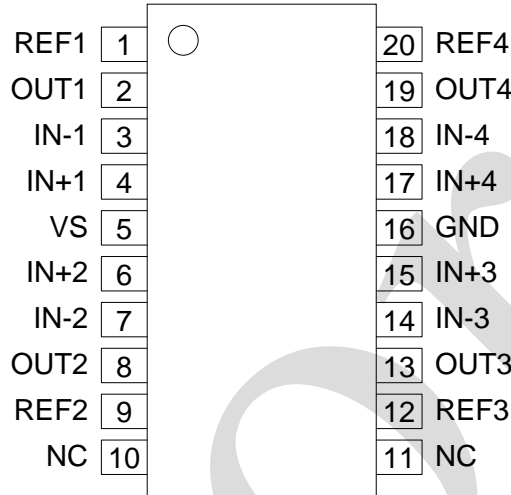

Figure 4. TSSOP20 (AiP48181)

2.3、Pin Description (AiP28181, AiP48181)

Pin Name	AiP28181	AiP48181	IO	Description
GND	4	16	Ground	Ground
IN-1	2	3	I	Channel 1 inverting input
IN+1	3	4	I	Channel 1 non-inverting input
IN-2	8	7	I	Channel 2 inverting input
IN+2	7	6	I	Channel 2 non-inverting input
IN-3	-	14	I	Channel 3 inverting input
IN+3	-	15	I	Channel 3 non-inverting input
IN-4	-	18	I	Channel 4 inverting input
IN+4	-	17	I	Channel 4 non-inverting input
NC	-	10, 11	-	floating
OUT1	1	2	O	Channel 1 output voltage
OUT2	9	8	O	Channel 2 output voltage
OUT3	-	13	O	Channel 3 output voltage
OUT4	-	19	O	Channel 4 output voltage
REF1	5	1	I	Channel 1 reference voltage
REF2	6	9	I	Channel 2 reference voltage
REF3	5	12	I	Channel 3 reference voltage
REF4	5	20	I	Channel 4 reference voltage
VS	10	5	Power	Supply voltage



2.4、Pin Configurations (AiP28180, AiP48180)

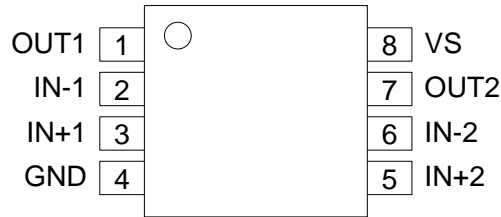

Figure 5. MSOP8 (AiP28180)

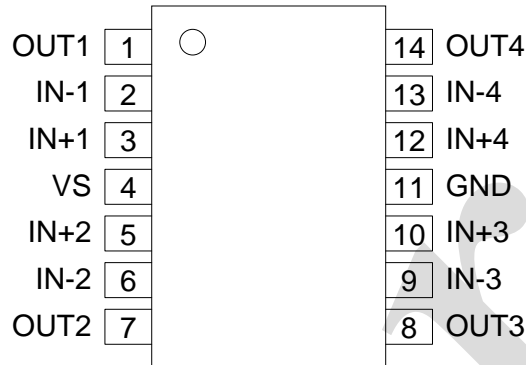

Figure 6. TSSOP14 (AiP48180)

2.5、Pin Description (AiP28180, AiP48180)

Pin Name	AiP28180	AiP48180	IO	Description
GND	4	11	Ground	Ground
IN-1	2	2	I	Channel 1 inverting input
IN+1	3	3	I	Channel 1 non-inverting input
IN-2	6	6	I	Channel 2 inverting input
IN+2	5	5	I	Channel 2 non-inverting input
IN-3	-	9	I	Channel 3 inverting input
IN+3	-	10	I	Channel 3 non-inverting input
IN-4	-	13	I	Channel 4 inverting input
IN+4	-	12	I	Channel 4 non-inverting input
OUT1	1	1	O	Channel 1 output voltage
OUT2	7	7	O	Channel 2 output voltage
OUT3	-	8	O	Channel 3 output voltage
OUT4	-	14	O	Channel 4 output voltage
VS	8	4	Power	Supply voltage



3、Electrical Parameter

3.1、Absolute Maximum Ratings

($T_{amb}=25^{\circ}\text{C}$, unless otherwise specified)

Characteristic	Symbol	Min.	Max.	Unit
Supply voltage	VS	-	6	V
Input voltage IN+, IN-	Differential (IN+)-(IN-)	-30	30	V
	Common-mode (VCM)	GND-0.2	35	V
Output current	I _{OUT}	-	8	mA
Junction temperature	T _J	-	150	°C
Storage temperature	T _{stg}	-65	150	°C
Soldering temperature (10s)	T _L	260		°C

3.2、ESD

Parameter	Symbol	Conditions	Value	Unit
ESD	HBM	ANSI/ESDA/JEDEC JS-001	±3	kV

3.3、Recommended Operating Conditions

Parameter	Symbol	Min.	Typ.	Max.	Unit
Common-mode input voltage	VCM	-0.2	12	30	V
Supply voltage	VS	2.7	5	5.5	V
Operating temperature	T _{amb}	-40	25	125	°C

3.4、Electrical Characteristics

($T_{amb}=25^{\circ}\text{C}$, $V_{SENSE}=(V_{IN+})-(V_{IN-})$, $V_S=5\text{V}$, $V_{IN+}=12\text{V}$, $V_{REF}=V_S/2$, unless otherwise specified)

Parameter	Symbol	Conditions	Min.	Typ.	Max.	Unit
Input						
input offset voltage	VOS	VSENSE=0mV	-	±100	±500	μV
		VSENSE=0mV, VIN+ =0V	-	±25	±150	μV
input offset voltage temperature drift	VOS TC	VSENSE=0mV, -40°C to 125°C	-	0.2	1	μV/°C
Common-mode input voltage	VCM	-40°C to 125°C	-0.2	-	30	V
Common-mode rejection ratio	CMRR	VIN+=0 to 30V, VSENSE=0mV, -40°C to 125°C	84	100	-	dB
Input bias current	IB	VSENSE=0mV, VIN+ = 0 V	-	-6	-	μA
		VSENSE=0mV	-	65	-	μA
Input offset current	IOS	VSENSE=0mV	-	±0.05	-	μA
Power supply rejection ratio	PSRR	V _S =+2.7V to 18V, VIN+=18V, VSENSE=0mV	-	±8	±40	μV/V
NOISE RTI (referred to input)						
Input voltage noise density	en	f = 1 kHz	-	40	-	nV/√Hz
Output						



Gain	G	AiPx8181A1/ AiPx8180A1	-	20	-	V/V
		AiPx8181A2/ AiPx8180A2	-	50	-	V/V
		AiPx8181A3/ AiPx8180A3	-	100	-	V/V
		AiPx8181A4/ AiPx8180A4	-	200	-	V/V
Gain error	EG	VOUT=0.5V to VS-0.5V, -40°C to 125°C	-	±0.1%	±1%	—
Gain error temperature drift	EG TC	-40°C to 125°C	-	1.5	20	ppm
Non-linear error	-	VOUT=0.5V to VS-0.5V	-	±0.01%	-	—
Maximum load capacitance	CLOAD	No sustained oscillation	-	1	-	nF
Output swing from the power supply rail	VOH	RLOAD=10kΩ to GND, -40°C to 125°C	-	VS-0.03	VS-0.02	V
Output swing from the ground rail	VOL	RLOAD=10kΩ to GND, -40°C to 125°C	-	VGND+0.0005	VGND+0.005	V
Frequency response						
Bandwidth	BW	CLOAD=10pF, AiPx8181A1, AiPx8180A1	-	350	-	kHz
		CLOAD=10pF, AiPx8181A2, AiPx8180A2	-	210	-	kHz
		CLOAD=10pF, AiPx8181A3, AiPx8180A3	-	150	-	kHz
		CLOAD=10pF, AiPx8181A4, AiPx8180A4	-	105	-	kHz
Slew rate	SR	AiPx8181A1, AiPx8180A1	-	2.5	-	V/μs
		AiPx8181A2, AiPx8180A2	-	4	-	V/μs
		AiPx8181A3, AiPx8180A3	-	6	-	V/μs
		AiPx8181A4, AiPx8180A4	-	8	-	V/μs
Power supply						
Supply voltage	VS	-	2.5	-	6	V
Quiescent current	IQ	AiP28181, AiP28180, VSENSE=0 mV	-	330	500	μA
		AiP28181, AiP28180, VSENSE=0 mV, -40°C to 125°C	-	-	600	μA
		AiP48181, AiP48180 VSENSE=0 mV	-	690	900	μA
		AiP48181, AiP48180, VSENSE=0 mV, -40°C to 125°C	-	-	1200	μA



4、Characteristic Curve

(The following is the characteristic curve of AiP28181A1.)

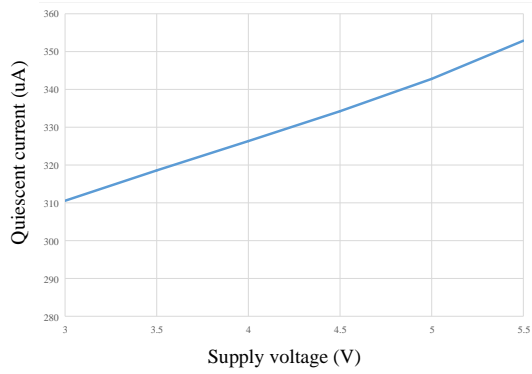

Figure 7. Supply voltage vs. Quiescent current

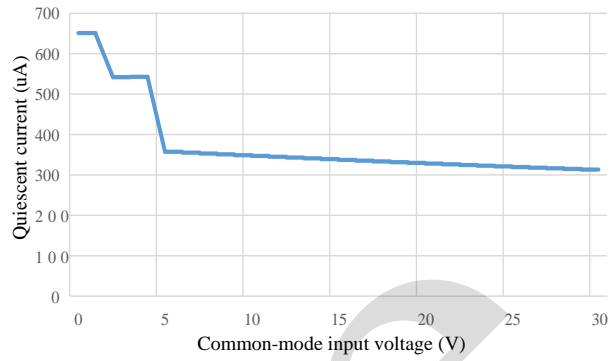

Figure 8. Common-mode input voltage vs. Quiescent current

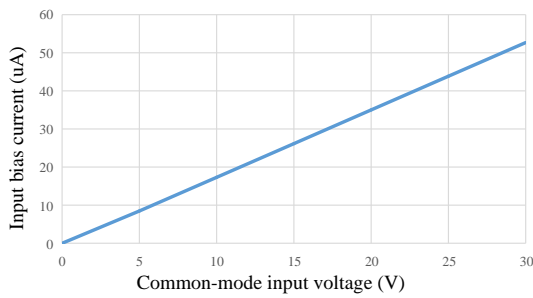

Figure 9. Common-mode input voltage vs. Input bias current
(VS=0V, VREF=0V)

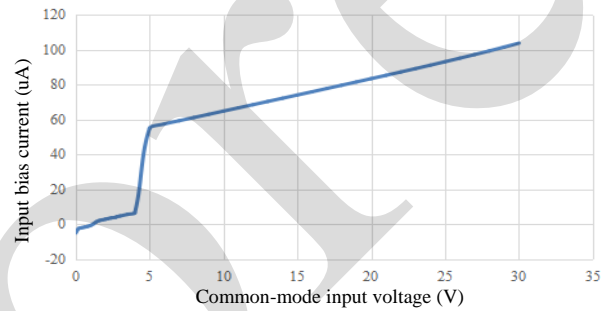

Figure 10. Common-mode input voltage vs. Input bias current
(VS=5V, VREF=2.5V)

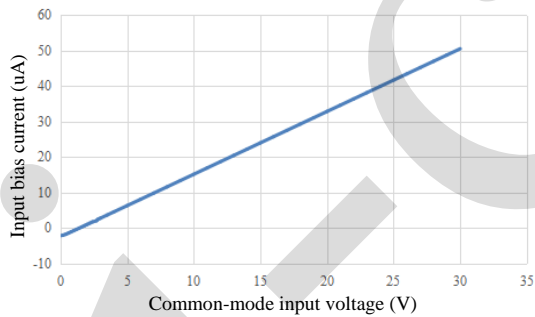

Figure 11. Common-mode input voltage vs. Input bias current
(VS=0V, VREF=2.5V)

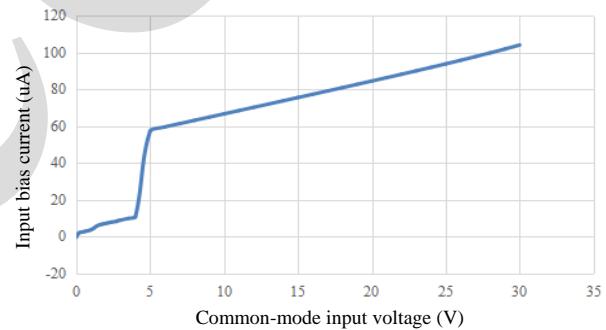

Figure 12. Common-mode input voltage vs. Input bias current
(VS=5V, VREF=0V)



5、Typical Application Circuit And Application Note

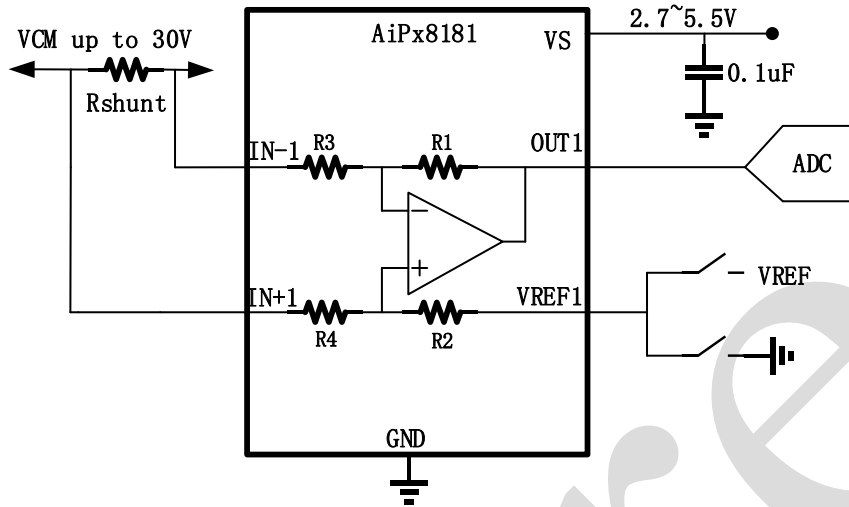

Figure 13. Typical application circuit of AiPx8181

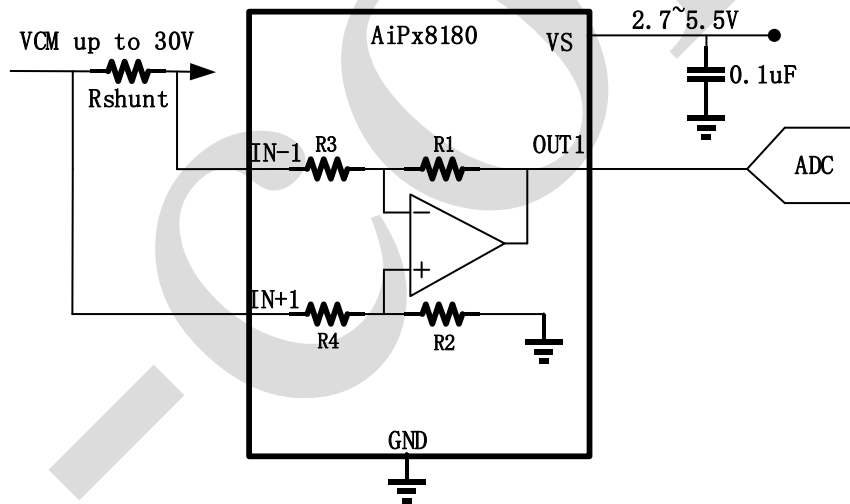
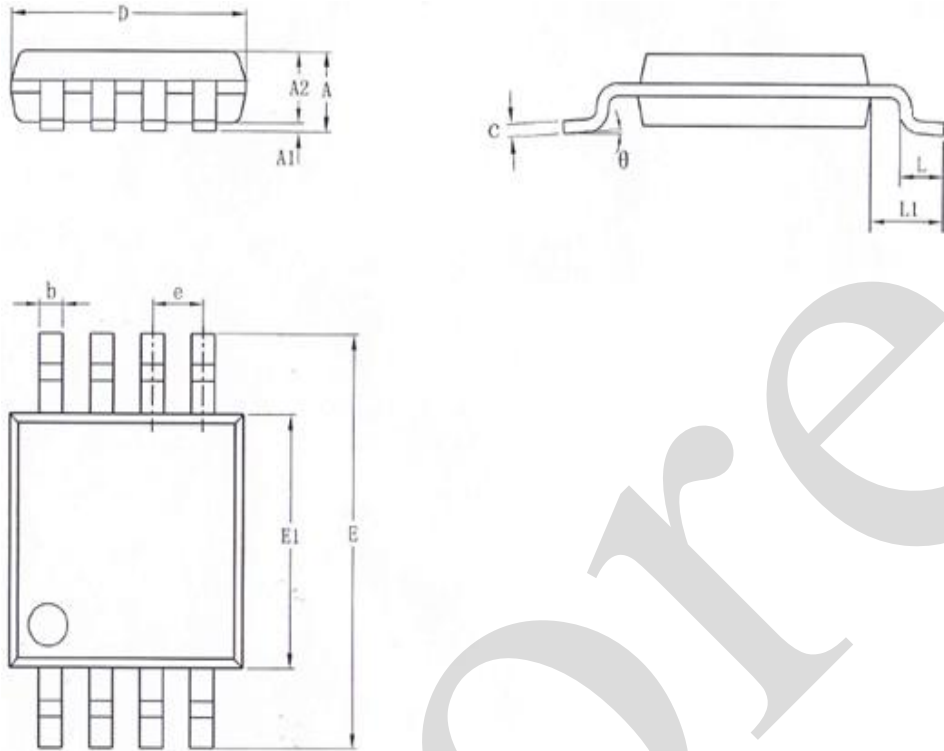

Figure 14. Typical application circuit of AiPx8180

The figures above show the basic application connection for AiPx8181/AiPx8180. The input pins IN+ and IN- should be connected directly to the sense resistor as close as possible to minimize any resistance in series with the sense resistor. To ensure stability, a power supply bypass capacitor should be placed close to the device pins.

**6、Package Information****6.1、MSOP8**

2023/12/A Symbol	Dimensions In Millimeters	
	Min	Max
A	—	1.10
A1	0.05	0.15
A2	0.75	0.95
b	0.22	0.38
c	0.08	0.23
D	2.90	3.10
E	4.70	5.10
E1	2.90	3.10
e	0.65	
L	0.40	0.80
L1	0.95	
θ	0°	8°



6.2、MSOP10

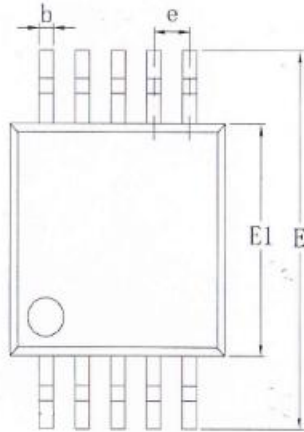
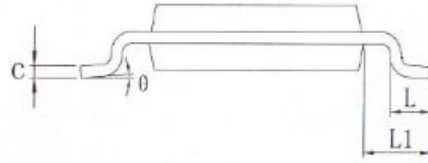
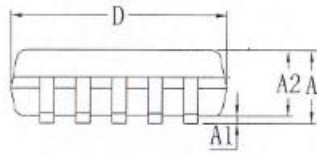

2023/12/A	Dimensions In Millimeters	
Symbol	Min	Max
A	—	1.10
A1	0.05	0.15
A2	0.75	0.95
b	0.17	0.27
c	0.08	0.23
D	2.90	3.10
E	4.70	5.10
E1	2.90	3.10
e	0.50	
L	0.40	0.80
L1	0.95	
θ	0°	8°



6.3、TSSOP14

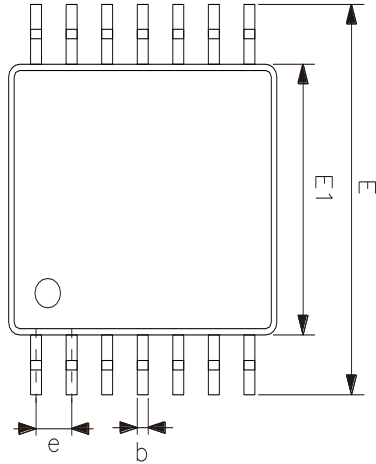
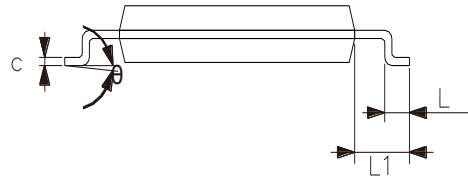
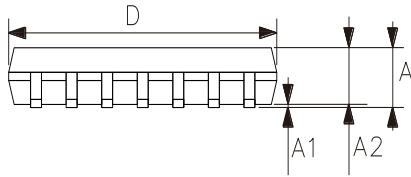

2023/12/A	Dimensions In Millimeters	
Symbol	Min	Max
A	—	1.20
A1	0.05	0.15
A2	0.80	1.05
b	0.19	0.30
c	0.09	0.20
D	4.90	5.10
E1	4.30	4.50
E	6.20	6.60
e	0.65	
L	0.45	0.75
L1	1.00	
θ	0°	8°



6.4. TSSOP20

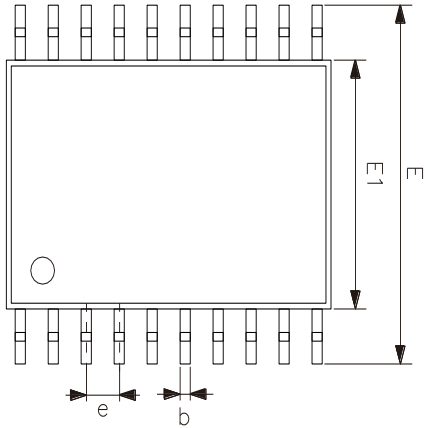
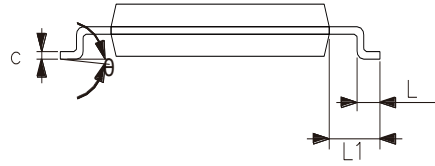
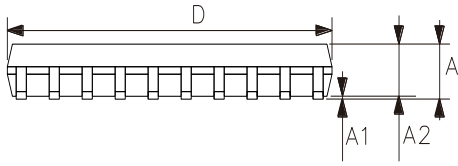

2023/12/A	Dimensions In Millimeters	
Symbol	Min	Max
A	—	1.20
A1	0.05	0.15
A2	0.80	1.05
b	0.19	0.30
c	0.09	0.20
D	6.40	6.60
E1	4.30	4.50
E	6.20	6.60
e	0.65	
L	0.45	0.75
L1	1.00	
θ	0°	8°



7、Statements And Notes

7.1、The name and content of Hazardous substances or Elements in the product

Part name	Hazardous substances or Elements									
	Lead and lead compounds	Mercury and mercury compounds	Cadmium and cadmium compounds	Hexavalent chromium compounds	Polybrominated biphenyls	Polybrominated biphenyl ethers	Dibutyl phthalate	Butylbenzyl phthalate	Di-2-ethylhexyl phthalate	Diisobutyl phthalate
Lead frame	○	○	○	○	○	○	○	○	○	○
Plastic resin	○	○	○	○	○	○	○	○	○	○
Chip	○	○	○	○	○	○	○	○	○	○
The lead	○	○	○	○	○	○	○	○	○	○
Plastic sheet installed	○	○	○	○	○	○	○	○	○	○
explanation	○: Indicates that the content of hazardous substances or elements in the detection limit of the following the SJ/T11363-2006 standard. ×: Indicates that the content of hazardous substances or elements exceeding the SJ/T11363-2006 Standard limit requirements.									

7.2、Notes

We recommend you to read this chapter carefully before using this product.

The information in this chapter is provided for reference only and i-Core disclaims any express or implied warranties, including but not limited to applicability, special application or non-infringement of third party rights.

This product is not suitable for critical equipment such as life-saving, life-sustaining or safety equipment. It is also not suitable for applications that may result in personal injury, death, or serious property or environmental damage due to product malfunction or failure. I-Core will not be liable for any damages incurred by the customers at their own risk for such applications.

The customer is responsible for conducting all necessary tests i-Core's application to avoid failure in the application or the application of the customer's third party users. I-Core does not accept any liability.

The Company reserves the right to change or improve the information published in this chapter at any time. The information in this chapter are subject to change without notice. We recommend the customer to consult our sales staff before purchasing.

Please obtain related materials form i-Core's regular channels and we are not responsible for its content if it is provided by sources other than our company.

In case of any conflict between the Chinese and English version, the version is subject to the Chinese one.