



钜地半导体  
Tudi Semiconductor

## Product Specification

TUDI-TS4890

1W Audio Power Amplifier with Shutdown Mode

网址 [www.sztdbdt.com](http://www.sztdbdt.com) Q

用芯智造 · 卓越品质

**semiconductor device  
manufacturer**

- Design
- research and development
- production
- and sales



## Features

- Operating from  $V_{CC} = 2.2\text{ V}$  to  $5.5\text{ V}$
- $1\text{ W}$  rail-to-rail output power @  $V_{CC} = 5\text{ V}$ ,  $\text{THD} = 1\%$ ,  $f = 1\text{ kHz}$ , with  $8\ \Omega$  load
- Ultra low consumption in standby mode
- Pop and click reduction circuitry
- Ultra low distortion ( $0.1\%$ )
- Unity gain stable
- Available in SO8 DIP8 and MiniSO8

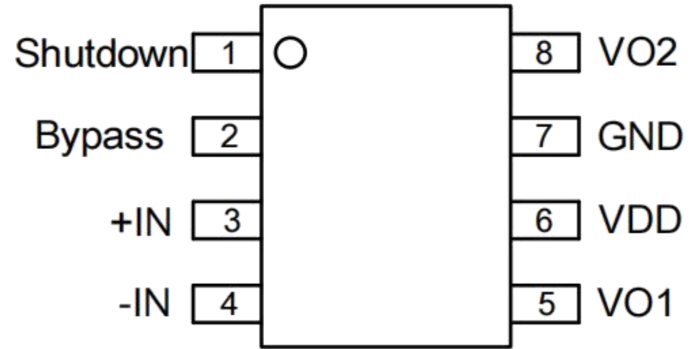

TS4890 Pin Diagram

## Description

The TS4890 is an Audio Power Amplifier capable of delivering  $1\text{ W}$  of continuous RMS Output Power into  $8\ \Omega$  load @  $5\text{ V}$ .

This Audio Amplifier is exhibiting  $0.1\%$  distortion level (THD) from a  $5\text{ V}$  supply for a  $P_{out} = 1\text{ W}$  RMS. An external standby mode control reduces the supply current to less than  $10\text{ nA}$ . An internal thermal shutdown protection is also provided.

The TS4890 has been designed for high quality audio applications such as mobile phones and to minimize the number of external components.

The unity-gain stable amplifier can be configured by external gain setting resistors.

## Applications

- Mobile Phones (Cellular / Cordless)
- Laptop / Notebook Computers
- PDAs
- Portable Audio Devices



## Pin description

PIN NO	PIN NAME	DESCRIPTION
1	Shutdown	Shutdown control pin (high level turns off the power amplifier)
2	Bypass	Internal common-mode voltage pin, requires an external 1 $\mu$ F bypass capacitor
3	+IN	Audio input terminal, positive phase
4	-IN	Audio input terminal, negative phase
5	VO1	Audio output terminal, negative phase
6	VDD	Power output terminal 1
7	GND	Power supply ground
8	VO2	Audio output terminal 2

## Typical Application

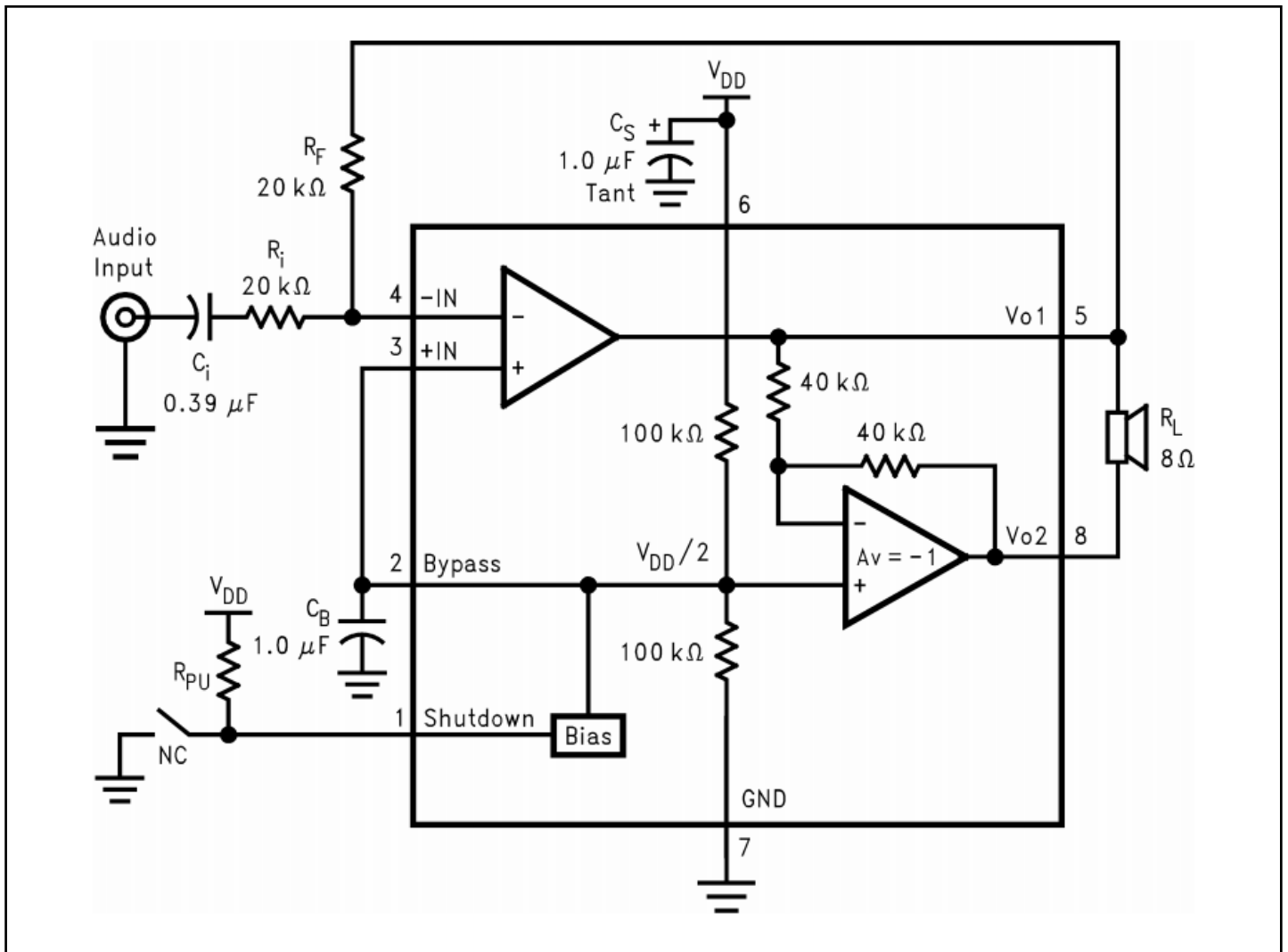



## Absolute Maximum Ratings<sup>(1)(2)</sup>

Supply Voltage		6.0V	
Supply Temperature		-65°C to +150°C	
Input Voltage		-0.3V to VDD to +0.3V	
Power Dissipation(3)		Internally Limited	
ESD Susceptibility(4)		5000V	
ESD Susceptibility <sup>5)</sup>		250V	
Junction Temperature		150°C	
Soldering Information	Small Outline Package	Vapor Phase(60 sec.)	215°C
		Infrared(15 sec.)	220°C

(1) Absolute Maximum Ratings indicate limits beyond which damage to the device may occur. Operating Ratings indicate conditions for which the device is functional, but do not ensure specific performance limits. Electrical Characteristics state DC and AC electrical specifications under particular test conditions which ensure specific performance limits. This assumes that the device is within the Operating Ratings. Specifications are not ensured for parameters where no limit is given, however, the typical value is a good indication of device performance.

(2) If Military/Aerospace specified devices are required, please contact the Texas Instruments Sales Office/Distributors for availability and specifications.

(3) The maximum power dissipation must be derated at elevated temperatures and is dictated by  $T_{JMAX}$ ,  $J_A$ , and the ambient temperature  $T_A$ . The maximum allowable power dissipation is  $P_{DMAX} = (T_{JMAX} - T_A) / J_A$  or the number given in Absolute Maximum Ratings, whichever is lower. For the TS4890,  $T_{JMAX} = 150^\circ\text{C}$ . For the  $J_A$ 's for different packages, please see the Application Information section or the absolute maximum ratings section.

(4) Human body model, 100pF discharged through a 1.5kΩ resistor.

(5) Machine Model, 220pF–240pF discharged through all pins.

## Operating Ratings

Temperature Range $T_{MIN} \leq T_A \leq T_{MAX}$	$-40^\circ\text{C} \leq T_A \leq 85^\circ\text{C}$
Supply Voltage	$2.0\text{V} \leq V_{DD} \leq 5.5\text{V}$

## Electrical Characteristics<sup>(1)(2)</sup>

The following specifications apply for  $V_{DD} = 5\text{V}$  and  $R_L = 8\Omega$  unless otherwise specified. Limits apply for  $T_A = 25^\circ\text{C}$ .

Symbol	Parameter	Conditions	TS4890			Units
			Min(3)	Typical	Limit(3)	
VDD	Supply Voltage		2.0		5.5	V
DD	Quiescent Power Supply Current	$V_{In} = 0\text{V}, I_o = 0\text{A}$		6.5	10.0	mA
IsD	Shutdown Current	$V_{PIN1} = V_{DD}$		0.6	2	μA
Vos	Output Offset Voltage	$V_{In} = 0\text{V}$		5.0	50	mV

(1) Absolute Maximum Ratings indicate limits beyond which damage to the device may occur. Operating Ratings indicate conditions for which the device is functional, but do not ensure specific performance limits. Electrical Characteristics state DC and AC electrical specifications under particular test conditions which ensure specific performance limits. This assumes that the device is within the Operating Ratings. Specifications are not ensured for parameters where no limit is given, however, the typical value is a good indication of device performance.

(2) All voltages are measured with respect to the ground pin, unless otherwise specified.

(3) Typicals are specified at 25°C and represent the parametric norm.



## Electrical Characteristics<sup>(1)(2)</sup> (continued)

The following specifications apply for  $V_{DD} = 5V$  and  $R_L = 8\Omega$  unless otherwise specified. Limits apply for  $T_A = 25^\circ C$ .

Symbol	Parameter	Conditions	TS4890			Units
			Min(3)	Typical(4)	Limit(3)	
P <sub>o</sub>	Output Power	THD=1%, f=1kHz RL=8Ω(5)		2.38 2 1.2		W
		THD+N=10%, f=1kHz RL=8Ω(5)		3 2.5 1.5		W
THD+N	Total Harmonic Distortion+Noise	20Hz ≤ f ≤ 20kHz, Av=2 RL=8Ω, Po=1W		0.13 0.25		%
PSRR	Power Supply Rejection Ratio	VDD=4.9V to 5.1V		60		dB

## External Components Description

Components		Functional Description
1.	R <sub>i</sub>	Inverting input resistance that sets the closed-loop gain in conjunction with R <sub>f</sub> . This resistor also forms a high pass filter with C <sub>i</sub> at $f_c = 1/(2\pi R_i C_i)$ .
2.	C <sub>i</sub>	Input coupling capacitor that blocks the DC voltage at the amplifiers input terminals. Also creates a highpass filter with R <sub>i</sub> at $f_c = 1/(2\pi R_i C_i)$ . Refer to the section, <a href="#">Proper Selection of External Components</a> , for an explanation of how to determine the value of C <sub>i</sub> .
3.	R <sub>f</sub>	Feedback resistance that sets the closed-loop gain in conjunction with R <sub>i</sub> .
4.	C <sub>S</sub>	Supply bypass capacitor that provides power supply filtering. Refer to the <a href="#">Power Supply Bypassing</a> section for information concerning proper placement and selection of the supply bypass capacitor.
5.	C <sub>B</sub>	Bypass pin capacitor that provides half-supply filtering. Refer to the section, <a href="#">Proper Selection of External Components</a> , for information concerning proper placement and selection of C <sub>B</sub> .

## Chip Power Consumption

Power consumption is one of the key metrics for amplifiers. The maximum self-power consumption of a differential output amplifier is:  $P_{D_{MAX}} = 4 \times (V_{DD})^2 / (2 \times \pi^2 \times R_L)$ .

It must be noted that self-power consumption is a function of output power.

During circuit design, the internal chip temperature must not exceed T<sub>JMAX</sub> (150°C). The design should be based on the chip's thermal resistance  $\theta_{JA}$ , and heat dissipation performance can be enhanced by incorporating dedicated copper or platinum cooling fins.

If the chip still fails to meet the requirements, solutions include increasing the load resistance, reducing the power supply voltage, or lowering the ambient temperature.



## Power Supply Bypass

In amplifier applications, the bypass design of the power supply is critical, particularly for noise performance and voltage rejection characteristics of the application. The design requires that the bypass capacitor be positioned as close as possible to the chip and power pins. A typical configuration consists of a 10  $\mu\text{F}$  electrolytic capacitor connected in parallel with a 0.1  $\mu\text{F}$  ceramic capacitor.

In the TS4890 application circuit, another capacitor CB (connected to the BYP pin) is also critical, as it influences PSRR and switching noise performance. Ceramic capacitors with capacitance values ranging from 0.1  $\mu\text{F}$  to 1  $\mu\text{F}$  are typically selected.

## Shut Down Footwork Mode Selection

To conserve power, the amplifier can be turned off when not in use. The TS4890 features a shutdown control pin that determines whether the amplifier operates. The voltage level on this control pin must match the required interface control signal; otherwise, the chip may enter an unstable state. By applying one of three distinct voltage levels to the Shutdown pin, the chip switches between three different operating modes:

**Low level:** The chip is in normal operating mode. Therefore, during use, ensure this pin remains at a low level.

**High level:** The chip enters power-off operation mode, with the amplifier disabled and no output signal. Selecting this state effectively reduces energy consumption, achieving power-saving objectives.

**Floating state:** The chip remains in an unstable condition. It cannot enter power-saving mode, its selfpower consumption does not decrease, and the energy-saving objective is unattainable; moreover, this state adversely affects the chip. Therefore, during prolonged operation, the chip must never be left in a floating state.

## Selection of Peripheral Components

Proper selection of peripheral components is essential to ensure chip performance. Although the TS4890 offers substantial performance margin, correct component selection remains critical for optimal overall performance.

The TS4890 features stable unit gain, making it widely applicable. Unit-gain amplification is typically employed to reduce THD + N and maximize the signal-to-noise ratio. However, this requires the highest possible input voltage; standard CODECs can only provide an output voltage of 1 V<sub>rms</sub>.

Additionally, the closed-loop bandwidth must be ensured, as the input coupling capacitance  $C_i$  (forming a first-order high-pass filter) determines the low-frequency response.



## Select Input Coupling Capacitor

An excessively large input capacitor increases both cost and footprint, which is highly disadvantageous for applications with limited budget and space constraints. Clearly, determining the appropriate capacitance value for coupling is crucial. In practice, speakers often fail to reproduce low-frequency sounds below 100 – 150 Hz; thus, using a large capacitor does not improve system performance. Beyond system performance considerations, the suppression of switching noise depends on the capacitor size: a larger coupling capacitor results in greater delay in the feedback network, leading to pop noise. Therefore, a smaller coupling capacitor can reduce this noise. Additionally, the capacitance value of the CB capacitor must be considered. Selecting  $C_B = 1 \mu\text{F}$  with  $C_i$  ranging from  $0.1 \mu\text{F}$  to  $0.39 \mu\text{F}$  will meet the system performance requirements

## Design Reference Example

Power Output	1Wrms
Load Impedance	$8\Omega$
Input Level	1 Vrms
Input Impedance	20 k $\Omega$
Bandwidth	100 Hz-20 kHz $\pm$ 0.25 dB

## First, Determine the Minimum Operating Voltage.

Based on the relationship between the output power of the TS4890 and the supply voltage, a supply voltage of 5.0 V should be selected. The voltage margin ensures that the output power can exceed 1 W without distortion. After selecting the voltage, consider the power consumption issue.

## Determine Voltage Gain

The requirement is that AVD be greater than  $\text{SQRT}(P_O \times R_L)/V_{IN}$ , i.e.,  $V_{orms}/V_{inrms}$ , with  $R_f/R_i = \text{AVD}/2$ . In this design, the minimum AVD calculated is 2.83; selecting AVD = 3 yields  $R_i = 20 \text{ K}$  and  $R_f = 30 \text{ K}$ .

## Other Precautions

The TS4890 offers stable unit gain; however, when the gain exceeds 10-fold (20 dB), an additional feedback capacitor  $C_f$  must be connected in parallel with resistor  $R_f$  to prevent high-frequency oscillation. The combined frequency of the poles formed by  $C_f$  and  $R_f$  must exceed  $f_H$  (300 kHz in this example). Using  $C_f = 25 \text{ pF}$  yields a cutoff frequency of 320 kHz, which meets the requirement.



## Finally, Determine the Input Capacitance Based on the Bandwidth Requirements.

The input low-frequency-3 dB bandwidth is 100 Hz, with the 1/5 low-frequency point approximately 0.17 dB below-3 dB and the 5-fold high-frequency point within the specification requirements. Let  $f_L = 20$  Hz and  $f_H = 100$  kHz; thus,  $C_i$  is approximately 0.39  $\mu$ F.

The high-frequency band  $f_H$  is determined by the amplifier's GBW, with a minimum requirement of  $GBW > AVD \times f_H = 300$  kHz – significantly lower than the TS4890F's 2.5 MHz.

## Order information

Order Number	Package	Package Quantity	Marking On The park	Temperature
TS4890IDT-TUDI	SOP8	Tape,Reel,2500	4890	-40°C to 85°C
TS4890IST-TUDI	MSOP8	Tape,Reel,2500	4890I	
TS4890IN-TUDI	DIP8	Tube,50,A box of 2000	TS4890IN	



## Package SOP8

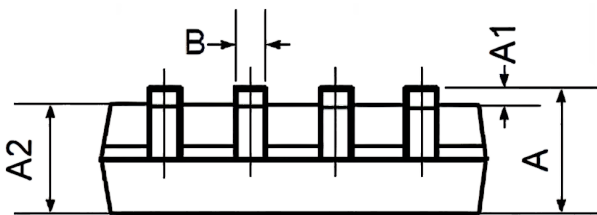
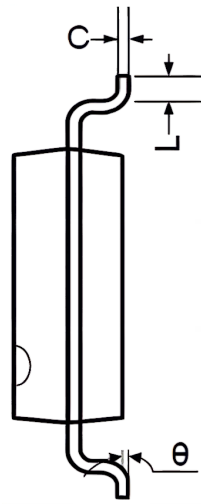
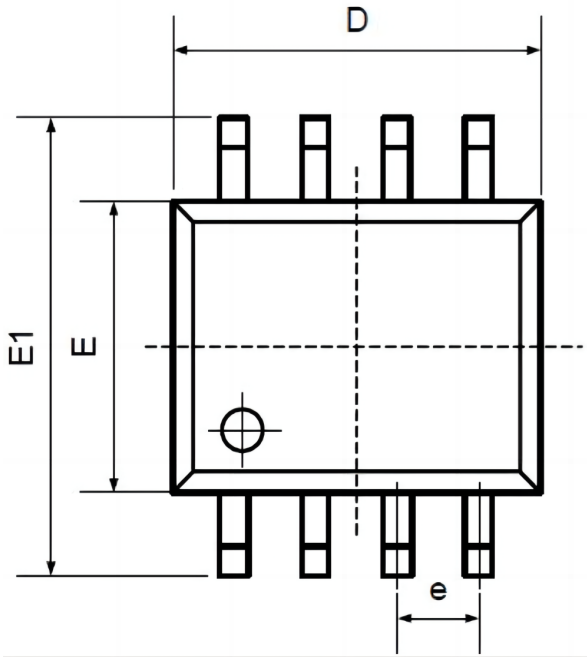

Symbol	Dimensions In Millimeters		Dimensions In Inches	
	Min	Max	Min	Max
A	1.350	1.750	0.053	0.069
A1	0.100	0.250	0.004	0.010
A2	1.350	1.550	0.053	0.061
B	0.330	0.510	0.013	0.020
C	0.190	0.250	0.007	0.010
D	4.780	5.000	0.188	0.197
E	3.800	4.000	0.150	0.157
E1	5.800	6.300	0.228	0.248
e	1.270TYP		0.050TYP	
L	0.400	1.270	0.016	0.050
$\theta$	0°	8°	0°	8°



## Package MSOP8

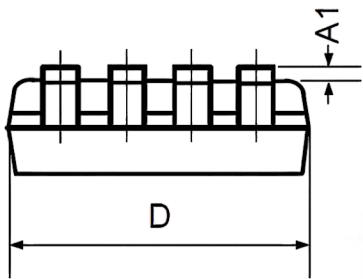
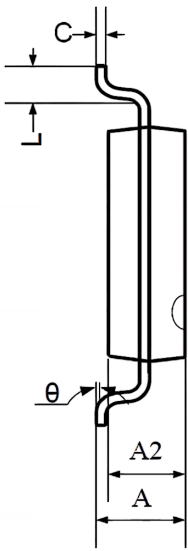
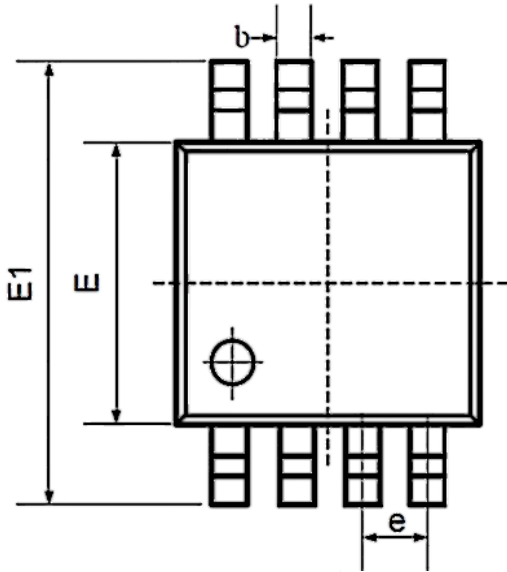

Symbol	Dimensions In Millimeters		Dimensions In Inches	
	Min	Max	Min	Max
A	0.800	1.200	0.031	0.047
A1	0.000	0.200	0.000	0.008
A2	0.760	0.970	0.030	0.038
b	0.30 TYP		0.012 TYP	
C	0.15 TYP		0.006 TYP	
D	2.900	3.100	0.114	0.122
e	0.65 TYP		0.026 TYP	
E	2.900	3.100	0.114	0.122
E1	4.700	5.100	0.185	0.201
L	0.410	0.650	0.016	0.026
θ	0°	6°	0°	6°



## Package DIP8

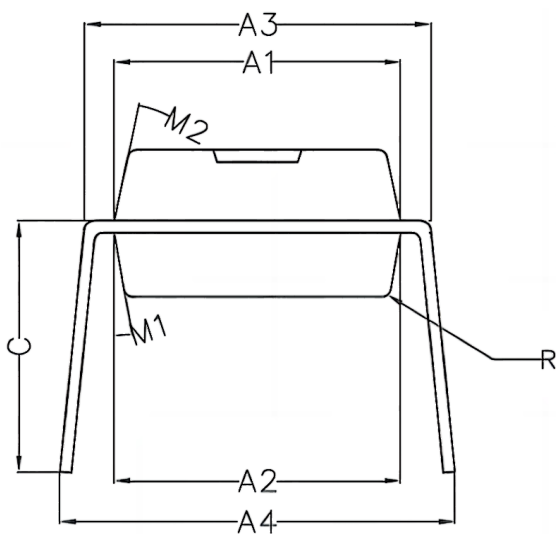
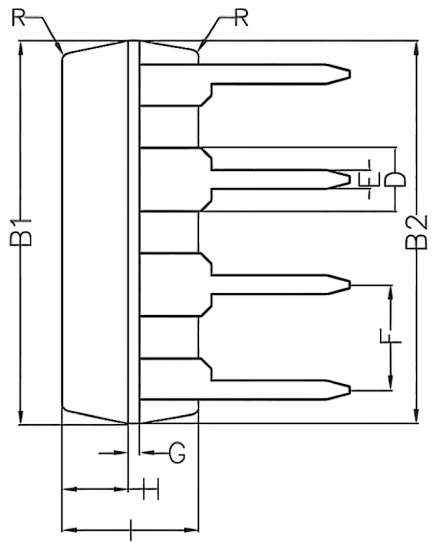
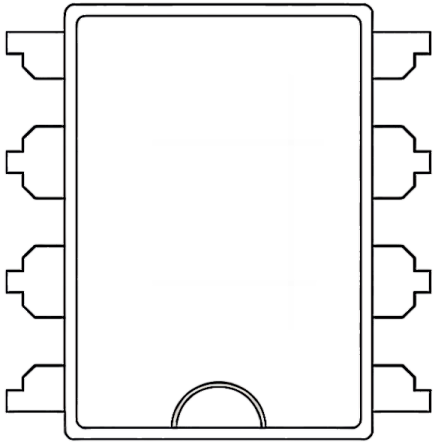

Symbol	Min	Non	Max
A1	6.28	6.33	6.38
A2	6.33	6.38	6.43
A3	7.52	7.62	7.72
A4	7.80	8.40	9.00
B1	9.15	9.20	9.25
B2	9.20	9.25	9.30
C		5.57	
D		1.52	
E	0.43	0.45	0.47
F		2.54	
G		0.25	
H	1.54	1.59	1.64
I	3.22	3.27	3.32
R		0.20	
M1	9°	10°	11°
M2	11°	12°	13°



## Important statement:

- TUDI Semiconductor reserves the right to modify the product manual without prior notice! Before placing an order, customers need to confirm whether the obtained information is the latest version and verify the completeness of the relevant information.
- Any semi-guide product is subject to failure or malfunction under specified conditions. It is the buyer's responsibility to comply with safety standards when using TUDI Semiconductor products for system design and whole machine manufacturing. And take the appropriate safety measures to avoid the potential in the risk of loss of personal injury or loss of property situation!
- TUDI Semiconductor products have not been licensed for life support, military, and aerospace applications, and therefore TUDI Semiconductor is not responsible for any consequences arising from the use of this product in these areas.
- If any or all TUDI Semiconductor products (including technical data, services) described or contained in this document are subject to any applicable local export control laws and regulations, they may not be exported without an export license from the relevant authorities in accordance with such laws.
- The specifications of any and all TUDI Semiconductor products described or contained in this document specify the performance, characteristics, and functionality of said products in their standalone state, but do not guarantee the performance, characteristics, and functionality of said products installed in Customer's products or equipment. In order to verify symptoms and conditions that cannot be evaluated in a standalone device, the Customer should ultimately evaluate and test the device installed in the Customer's product device.
- TUDI Semiconductor documentation is only allowed to be copied without any alteration of the content and with the relevant authorization. TUDI Semiconductor assumes no responsibility or liability for altered documents.
- TUDI Semiconductor is committed to becoming the preferred semiconductor brand for customers, and TUDI Semiconductor will strive to provide customers with better performance and better quality products.