

REACH & RoHS
COMPLIANT

REV.	ECN / DESCRIPTION	BY	DATE

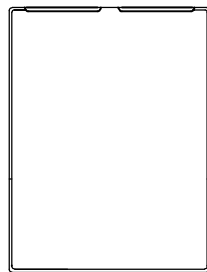

TOP VIEW

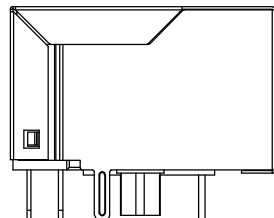

LEFT SIDE VIEW

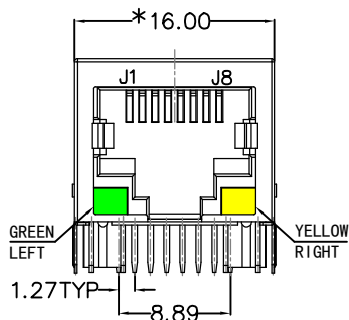

FRONT VIEW

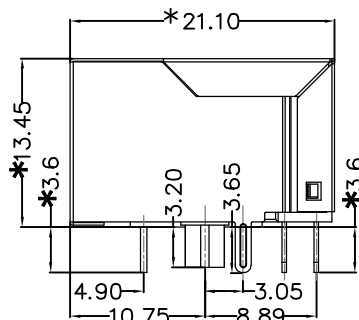

RIGHT SIDE VIEW

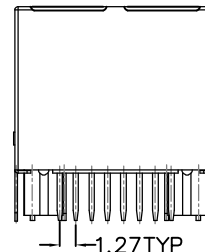

BACK VIEW

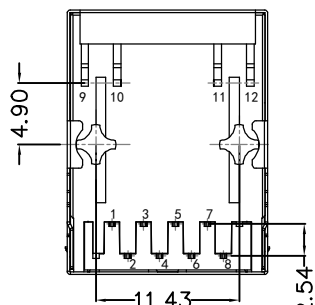

BOTTOM VIEW

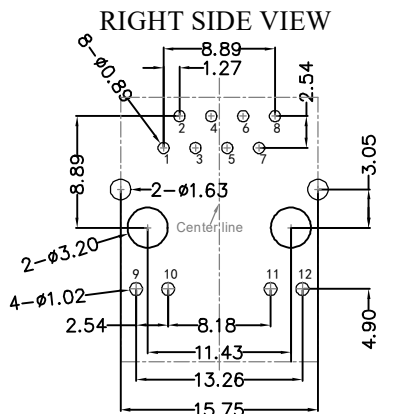

RECOMMENDED PCB LAYOUT
VIEWED FROM COMPONENT SIDE

MATERIAL:

HOUSING : PBT,UL94V-0,BLACK.
 TERMINALS BRACKET: PBT,UL94V-0,BLACK.
 SHIELD: C2680,T=0.20MM,NICKEL PLATING ON ALL AREA.
 TERMINAL: PHOSPHOR BRONZE C5210,T=0.35MM,
 6U" GOLD PLATING ON CONTACT AREA.

MECHANICAL:

DURABILITY : 750 CYCLES MIN.
 MATING FORCE : 23N MAX.
 OPERATING TEMPERATURE: -40°C~+85°C.
 STORAGE TEMPERATURE: -40°C~+85°C.
 ALL CRITICAL DIMENSIONS WITH "*"

深圳市富港科技有限公司

TITLE: TAB-DOWN 1X1 100BASE	SIZE A4	UNITS MM[INCH]	GENERAL TOLERANCES UNLESS SPECIFIED		APPROVED BY:
PART NO.: RJ-111B002BA2A1D	SACLE 1:1	REV A0	x±0.35	x°±3.0°	CHECKED BY:
REMARK:	SHEET 1/4		.x±0.30	.x°±2.0°	DESIGND BY:
			.xx±0.25	.xx°±1.5°	
			.xxx±0.10	.xxx°±1.0°	

REACH & RoHS
COMPLIANT

REV.	ECN / DESCRIPTION	BY	DATE

RECOMMENDED PANEL CUTOUT (REFERENCE ONLY):

KEEP-OUT AREA (COMPONENT SIDE VIEW):

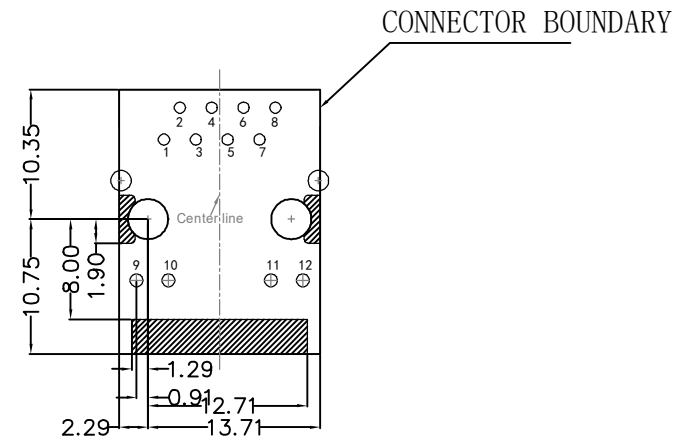
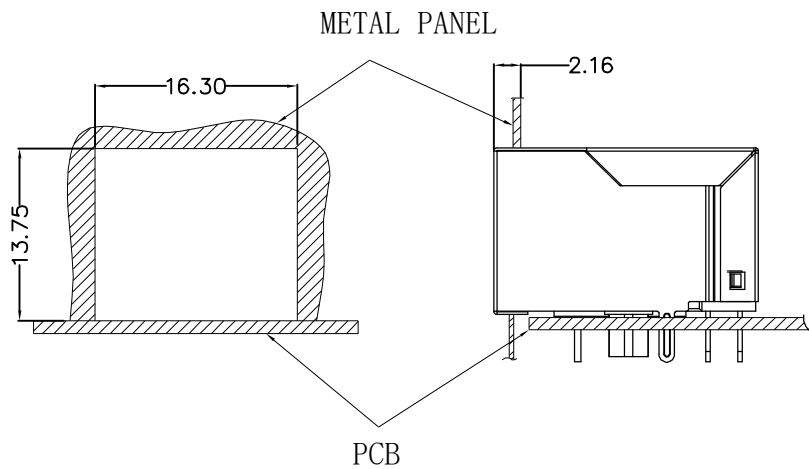

UNIT: MM / INCH
TOLERANCES: ± 0.10 / 0.004
REFERENCE ONLY

UNIT: MM / INCH
TOLERANCES: ± 0.10 / 0.004

深圳市富港科技有限公司

TITLE: TAB-DOWN 1X1 100BASE	SIZE A4	UNITS MM[INCH]	GENERAL TOLERANCES UNLESS SPECIFIED		APPROVED BY:
PART NO.: RJ-111B002BA2A1D	SACLE 1:1	REV A0	$x \pm 0.35$	$x^\circ \pm 3.0^\circ$	CHECKED BY:
REMARK:	SHEET 2/4		$.xx \pm 0.25$	$.xx^\circ \pm 1.5^\circ$	DESIGN BY:
			$.xxx \pm 0.10$	$.xxx^\circ \pm 1.0^\circ$	

REACH & RoHS
COMPLIANT

REV.	ECN / DESCRIPTION	BY	DATE

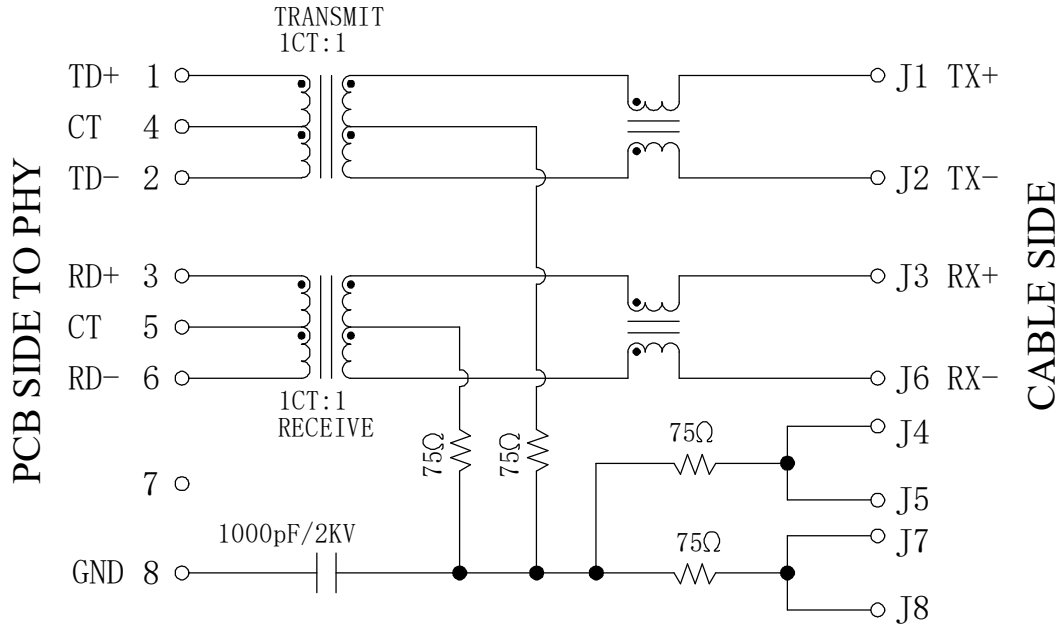

Electrical:

- Turn ratio: 1~2: J1~J2=1CT:1CT(±2%).
3~6: J3~J6=1CT:1CT(±2%).
- OCL: 350uH Min. at 100KHz 100mV 8mA DC.
- Insertion Loss: -1.0 dB Max 1~100MHz.
- Return loss: -20dB Min 1~10MHz;
-16dB Min 10~30MHz.
-12dB Min 30~60MHz.
-10dB Min 60~80MHz.
- Cross talk: -40dB Min 1~30MHz;
-35dB Min 30~60MHz;
-30dB Min 60~100MHz;
- CMR: -30dB Min 1~100MHz;
- Hi-Pot: 1500V AC & 2250V DC
6S 1mA PRI TO SEC

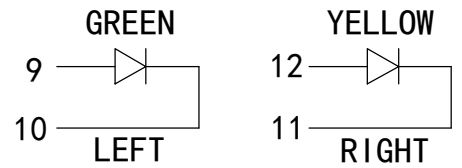

LED Specification

Standard LED Color	LED Wavelength	Foward(A)	Foward(V)
Green	568nm	20mA	1.85-2.45V
Yellow	585nm	20mA	1.7-2.2V

<p>深圳市富港科技有限公司</p>	TITLE: TAB-DOWN 1X1 100BASE	SIZE A4	UNITS MM[INCH]	GENERAL TOLERANCES UNLESS SPECIFIED		APPROVED BY:
	PART NO.: RJ-111B002BA2A1D	SACLE 1:1	REV A0	x±0.35	x°±3.0°	CHECKED BY:
	REMARK:	SHEET 3/4		.xx±0.25	.xx°±1.5°	DESIGND BY:
				.xxx±0.10	.xxx°±1.0°	

REACH & RoHS
COMPLIANT

PROFILE OF WAVE SOLDER

REV.	ECN / DESCRIPTION	BY	DATE

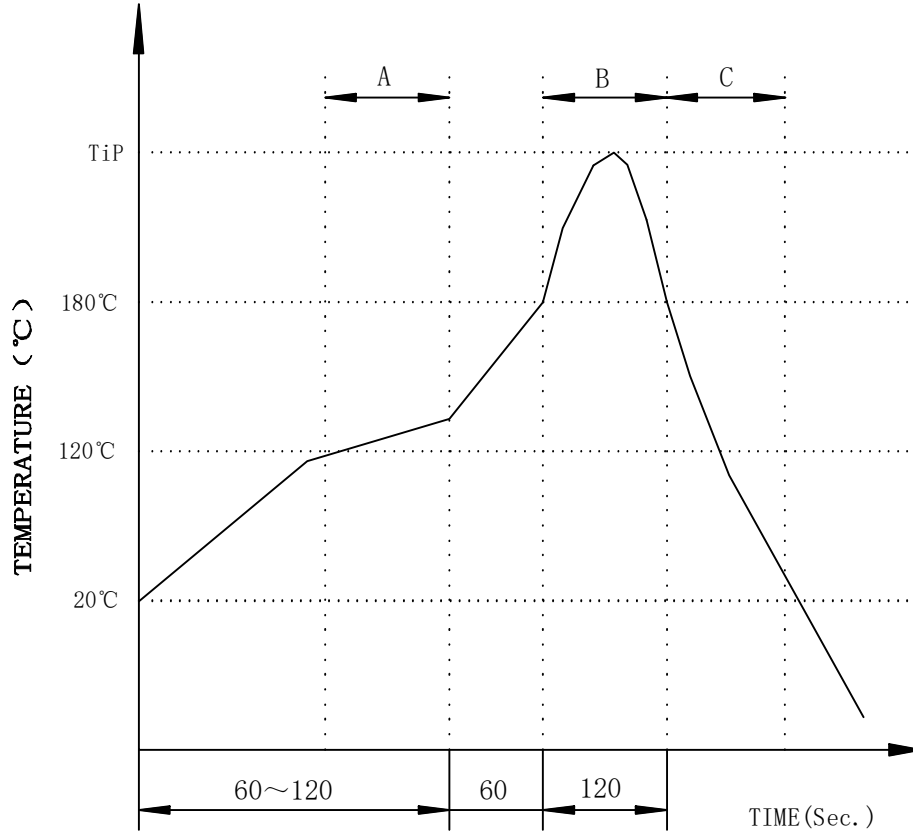

A.Preheating B.Soldering C.Gradual Cooling
 Tip temperature:260±5°C.
 Tip temperature time:5Sec Max.
 Tip melting point of Sn96.5/Ag3/Cu0.5:217°C.

Remarks: after wave soldering, the plastic
 positioning columns of the product which under the
 PCB will be slightly melted, but it won't affect its
 function.

深圳市富港科技有限公司

TITLE: TAB-DOWN 1X1 100BASE	SIZE A4	UNITS MM[INCH]	GENERAL TOLERANCES UNLESS SPECIFIED		APPROVED BY:
PART NO.: RJ-111B002BA2A1D	SACLE 1:1	REV A0	x±0.35 .x±0.30	x°±3.0° .x°±2.0°	CHECKED BY:
REMARK:	SHEET 4/4		.xx±0.25 .xxx±0.10	.xx°±1.5° .xxx°±1.0°	DESIGND BY: