

## Features

- Adjustable output voltage range: 2.5V~36V
- Low Dynamic Output Resistance: 0.15 $\Omega$ (typ)
- Low Temperature Deviation: 5mV(typ)
- Low Output Noise
- High Stability under Capacitive Load
- Current capacity range 1-100 mA

## Applications

- Adjustable voltage and current reference
- Zener diode replacement products
- Voltage monitoring
- A comparator with an integrated benchmark
- Secondary side voltage regulation in flyback switch mode power supply (SMPS)

## General Description

### Precision adjustable reference source

The is a three terminal adjustable parallel regulator that can Set the output voltage through two external resistors Between Vref (approximately 2.5V) and 36V Any value. These devices have an output of 0.15  $\Omega$  (typ) Output impedance. Active output circuits can provide very sharp The conductivity characteristics of these devices enable them to be used in many applications Becoming an excellent substitute for Zener diodes in use, this Some applications include onboard voltage regulation, adjustable power supply, and power on/off Power off.

## Ordering Information

ORDER NUMBER	ACCURACY	PACKAGE DESCRIPTION	PACKAGE OPTION
TL431 $\pm 0.1\%$	$\pm 0.1\%$	SOT23	Tape and Reel,3000
TL431 $\pm 0.2\%$	$\pm 0.2\%$	SOT23	Tape and Reel,3000
TL431 $\pm 0.3\%$	$\pm 0.3\%$	SOT23	Tape and Reel,3000

## Circuit diagram and pin information

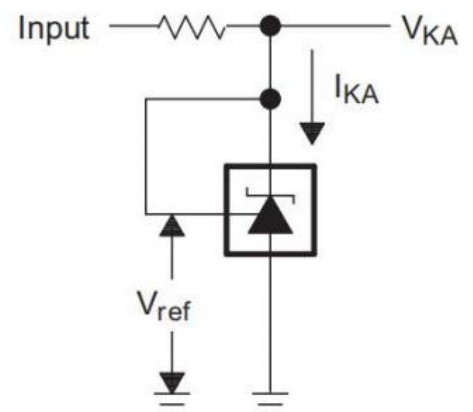
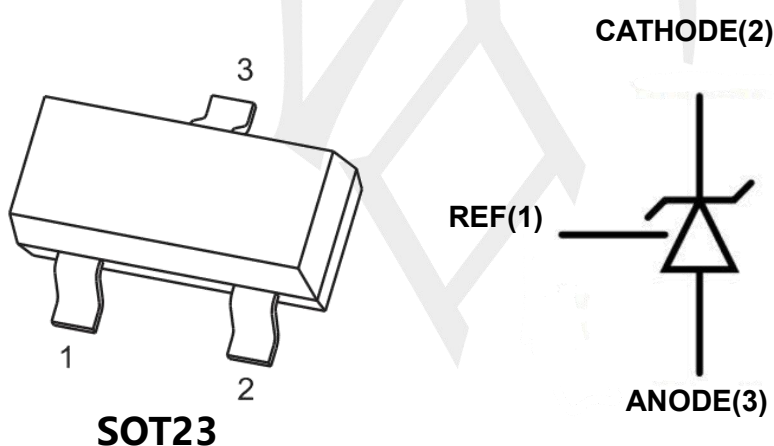

## Absolute Maximum Ratings

Within the range of  $T_A=25\text{ }^\circ\text{C}$  (unless otherwise specified)

Parameter		Value	UNIT
PM	Power Rating	0.25	W
VKA	Cathode voltage	36	V
IKA	Continuous cathode current range	-100 ~ +150	mA
I <sub>I(ref)</sub>	Reference input current range	10	mA
TOA	Operating Ambient Temperature Range	-40 ~ +125	°C
T <sub>J</sub>	Operating virtual junction temperature	+150	°C
T <sub>stg</sub>	Storage temperature range	-55 ~ +150	°C
ESD	Human Body Model	6	KV
ESD	Machine Model	0.4	KV

(1) Exceeding the absolute maximum rated pressure listed may result in permanent damage to the equipment. These are only rated stresses and do not imply any of them or any of them

The functional operation of the equipment under his conditions (beyond the conditions indicated under the 'recommended working conditions'). Long term exposure to absolute maximum rated conditions can It can affect the reliability of the equipment.

(2) Unless otherwise specified, all voltage values are related to the anode.

## BLOCK DIAGRAM

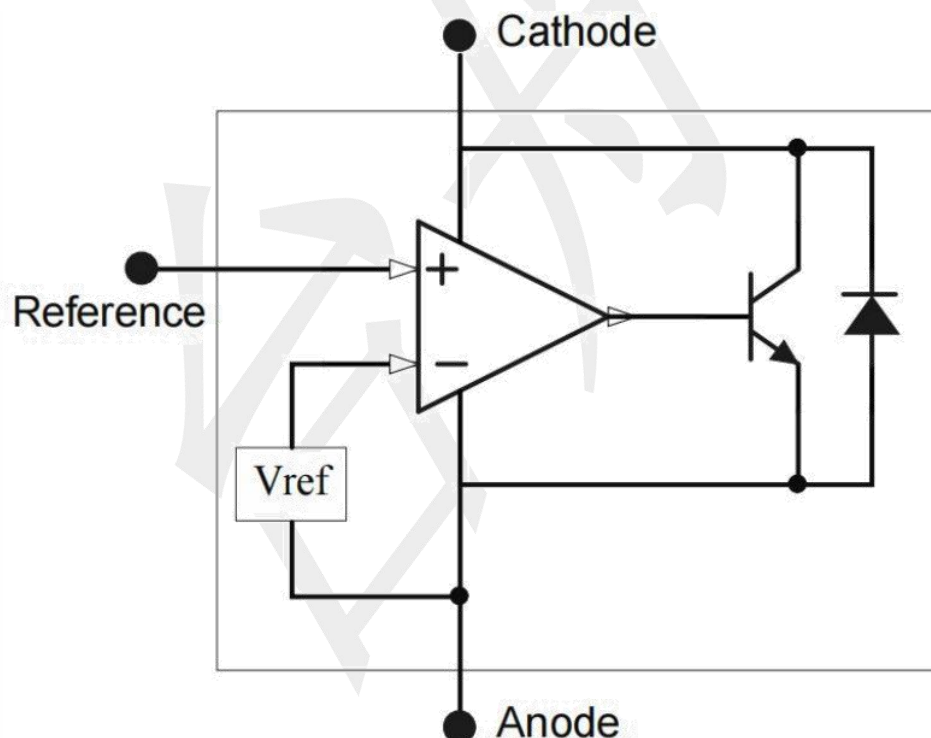

## Electrical Characteristics

Under recommended working conditions, TA=25 °C (unless otherwise specified)

PARAMETER	SYMBOL	TEST Conditions	MIN	TYP	MAX	UNIT	
Reference voltage (Fig.1)	V <sub>REF</sub>	V <sub>KA</sub> =V <sub>REF</sub> , I <sub>K</sub> =10mA	0.1%	2.4975	2.5000	2.5025	V
			0.2%	2.4950	2.5000	2.5050	
			0.3%	2.4925	2.5000	2.5075	
Continuous cathode current range	I <sub>KA</sub>	Operating Conditions	1.0	--	100	mA	
Deviation of reference input voltage over full temperature (1)(Fig.1)	V <sub>REF</sub> (DEV)	V <sub>KA</sub> =V <sub>REF</sub> , I <sub>K</sub> =10mA, T <sub>A</sub> =-20°C~110°C	--	5.0	10	mV	
Ratio of change in reference input voltage to the change in cathode voltage (Fig.2)	ΔV <sub>REF</sub> /ΔV <sub>KA</sub>	I <sub>K</sub> =10mA, ΔV <sub>KA</sub> =10V~V <sub>REF</sub>	--	0.4	--	mV/V	
		I <sub>K</sub> =10mA, ΔV <sub>KA</sub> =36V~10V	--	-0.4	--	mV/V	
Reference input current (Fig.2)	I <sub>REF</sub>	I <sub>K</sub> =10mA, R <sub>1</sub> =10KΩ, R <sub>2</sub> =∞	--	0.7	4.0	uA	
Deviation Of reference input current over full temperature range (Fig.2)	ΔI <sub>REF</sub>	I <sub>K</sub> =10mA, R <sub>1</sub> =10KΩ, R <sub>2</sub> =∞, T <sub>A</sub> =-10°C~125°C	--	0.4	1.2	uA	
Minimum cathode current for regulation (Fig.1)	I <sub>KMIN</sub>	V <sub>KA</sub> =V <sub>REF</sub>	--	0.35	1.0	mA	
Off-state cathode current (Fig.3)	I <sub>OFF</sub>	V <sub>KA</sub> =12V, V <sub>REF</sub> =0	--	0.05	1.0	uA	
Dynamic impedance	Z <sub>KA</sub>	V <sub>KA</sub> =V <sub>REF</sub> , I <sub>K</sub> =1mA~100 mA, f ≤1KHz	--	0.15	0.5	Ω	
Thermal Resistance	θ <sub>JC</sub>		--	115	--	°C/W	

Figure 1. Test Circuit for V<sub>KA</sub> = V<sub>ref</sub>

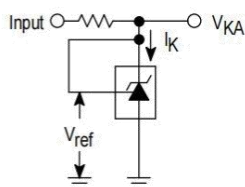

Figure 2. Test Circuit for V<sub>KA</sub> > V<sub>ref</sub>

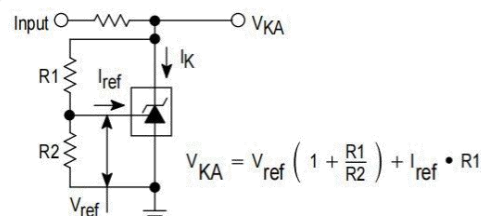
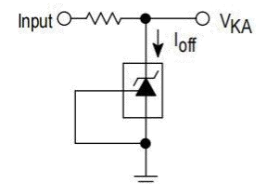
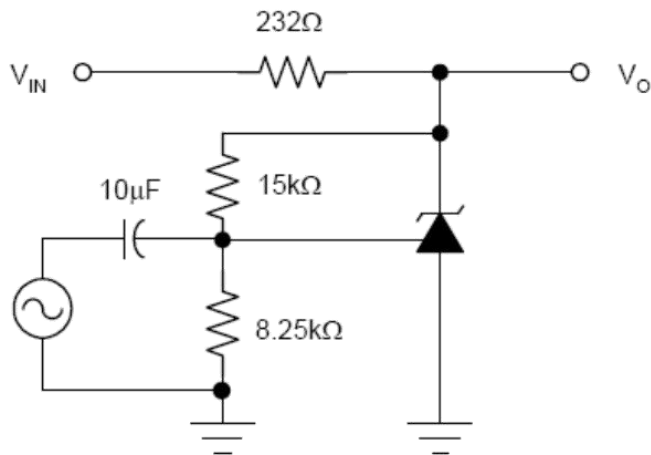

Figure 3. Test Circuit for I<sub>off</sub>



## Typical Application Circuits



Voltage Amplification  
Test Circuit

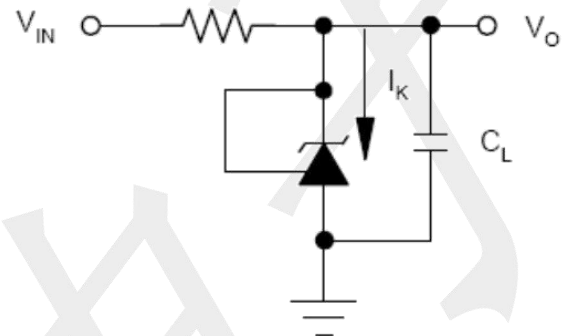

Stability Test Circuit for  $V_{KA} = V_{REF}$

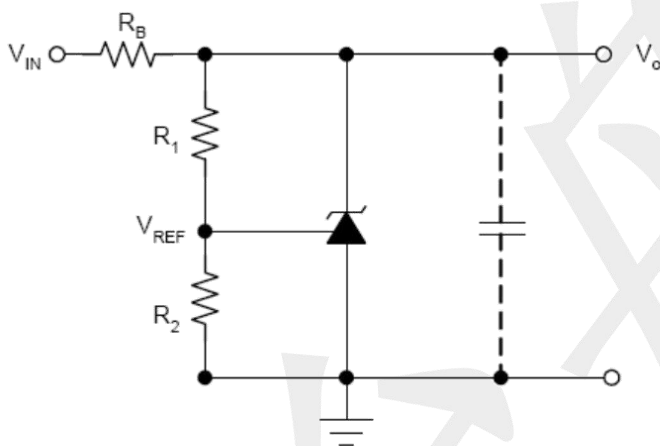

Precision Voltage Reference

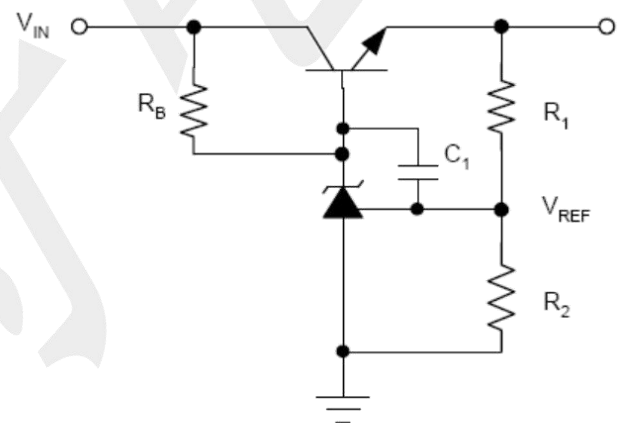

Precision High-Current Series Regulator

### Notes for Typical Application Circuits:

1. For the series regulator applications, add a compensation capacitor  $C_1$  between CATHODE and REF is strongly recommended to improve the stability of output voltage.
2. Set  $V_o$  according to the following equation:  $V_o = V_{REF}(1 + R_1/R_2) + I_{REF} \times R_1$ .
3. Choose the Value for  $R_B$  as below:
  - (1). The maximum limit for  $R_B$  should be such that the cathode current ( $I_K$ ) is greater than the minimum operating current (1mA) at  $V_{IN}(\text{MIN})$ .
  - (2). The minimum limit for  $R_B$  should be such that the cathode current ( $I_K$ ) does not exceed 100mA under all load conditions, and the instantaneous turn-on value for  $I_K$  does not exceed 120mA.

**Package Outline Dimensions (unit: mm)**

**SOT23**

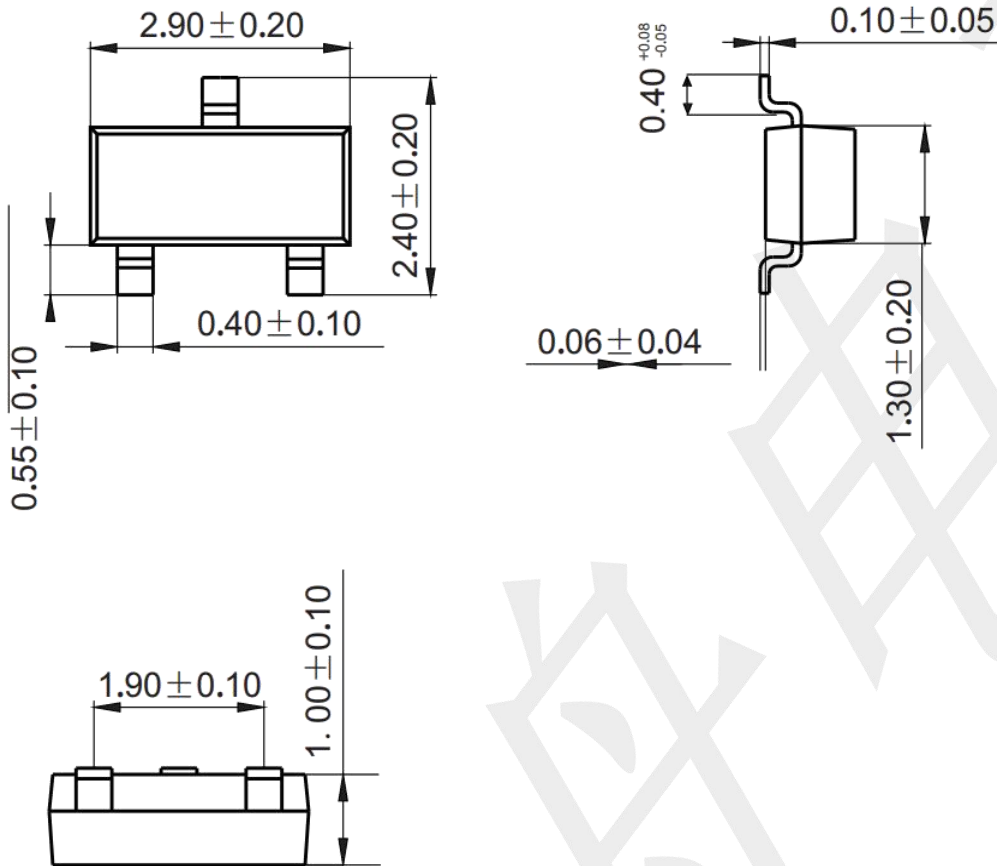

**Mounting Pad Layout (unit: mm)**

