

SKY13270-92LF-HX 20 MHz-2.7 GHz GaAs SPDT Switch

Description

The SKY13270-92LF-HX is a pHEMT GaAs FET Single Pole Double Throw (SPDT) high linearity switch. This wideband switch is designed for use in systems operating from 20 MHz to 2.7 GHz for which extremely high linearity, low control voltage, high isolation, low insertion loss, and ultra-miniature package size are required.

The device is controlled with positive, negative, or a combination of both voltages. The RF signal paths within the device are fully bilateral.

The SKY13270-92LF-HX is manufactured in a compact, low-cost 2.00 x 1.25 mm, 6-pin SC-70 package. A functional block diagram is shown in Figure 1. The pin configuration and package are shown in Figure 2. Signal pin assignments and functional pin descriptions are provided in Table 1.

Applications

- ★ Transmit/receive and diversity switching over 3 W
- ★ Analog and digital wireless communication systems including cellular, GSM, and UMTS

Features

- ★ Broadband frequency range: 20 MHz to 2.7 GHz
- ★ Very low insertion loss, 0.4 dB typical @ 1.0 GHz
- ★ High isolation: 24 dB typical @ 1.0 GHz
- ★ IP0.1dB = +37 dBm typical @ 3 V
- ★ Low current consumption: <100 μ A @ 3 V
- ★ Ultra-miniature, SC-70 (6-pin, 2.00 x 1.25 mm) package (MSL1, 260 °C per JEDEC J-STD-020)

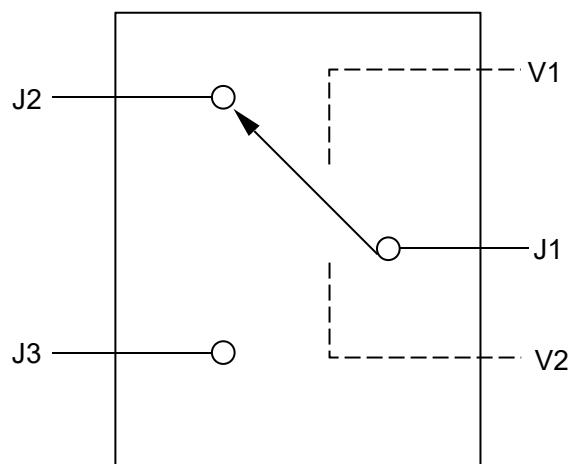

Figure 1. SKY13270-92LF-HX Block Diagram

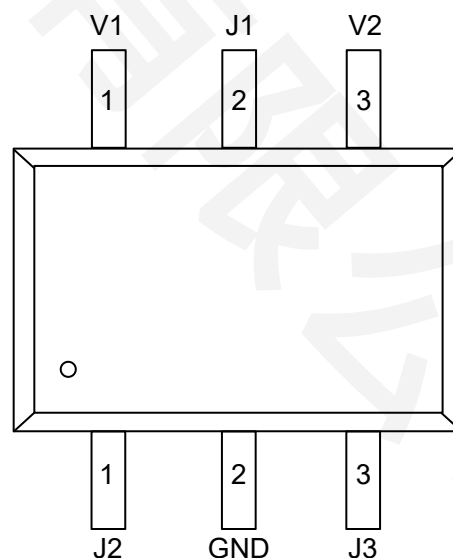

Figure 2. SKY13270-92LF-HX Pinout –6-Pin SC-70 (Top View)

Table 1. SKY13270-92LF-HX Signal Descriptions

Pin#	Name	Description	Pin#	Name	Description
1	J2	RF input/output. According to the logic voltage levels applied to the V1 and V2 pins, this port is either connected to J1 using a low insertion loss path or isolated from J1 (Note 1).	4	V2	DC control voltage input#2. The logic voltage applied to this pin, along with the voltage level applied to the V1 pin, determines the states of the RF paths between J1/J2 and J1/J3.
2	GND	Ground. Equipotential port, internal circuit common, which must connected to the PCB ground or common using the lowest possible impedance.	5	J1	RF input/output. According to the logic voltage levels applied to the V1 and V2 pins, this port is either connected to J2 or to J3 using a low insertion loss path and isolated from the other RF port (Note 1).
3	J3	RF input/output. According to the logic voltage levels applied to the V1 and V2 pins, this port is either connected to J1 using a low insertion loss path or isolated from J1 (Note 1).	6	V1	DC control voltage input#1. The logic voltage applied to this pin, along with the voltage level applied to the V2 pin, determines the states of the RF paths between J1/J2 and J1/J3.

Note 1:

A 100 pF blocking capacitor is required for >500 MHz operation. Use larger value capacitors for lower frequency operation.

Table 2. SKY13270-92LF-HX Absolute Maximum Ratings

Parameter	Symbol	Minimum	Maximum	Units
Control voltage	V _{CTL}	-0.2	+8.0	V
RF input power (V _{CTL} = 0-5V @ 0.9 GHz)	P _N		+37.8	dBm
Operating temperature	T _{OP}	-40	+85	°C
Storage temperature	T _{STG}	-65	+150	°C

Note: Exposure to maximum rating conditions for extended periods may reduce device reliability. There is no damage to device with only one parameter set at the limit and all other parameters set at or below their nominal value.

CAUTION:

Although this device is designed to be as robust as possible, Electrostatic Discharge (ESD) can damage this device. This device must be protected at all times from ESD. Static charges may easily produce potentials of several kilovolts on the human body or equipment, which can discharge without detection. Industry-standard ESD precautions should be used at all times.

Technical Description

The SKY13270-92LF-HX is controlled using two voltage inputs, V1 and V2 (pins 6 and 4, respectively). Depending on the voltage level applied to these pins, the common RF port (J1) is connected to one of two RF ports (J2 or J3) using a low insertion loss path, while the path between J1 and the other RF port is in its isolation state. When the control voltages are toggled, the states between J1 and J2, as well as J1 and J3, are also toggled.

Electrical and Mechanical Specifications

The absolute maximum ratings of the SKY13270-92LF-HX are provided in Table 2. Electrical specifications are provided in Table 3 and the operating characteristics are specified in Table 4.

Typical performance characteristics of the SKYA13270-92LF are illustrated in Figures 3 through 6. The state of the SKY13270-92LF-HX is determined by the logic provided in Table 5.

Table 3. SKY13270-92LF-HX Electrical Specifications (Note 1)

($V_{CTL} = 0-3\text{ V}$, $T_{OP} = +25\text{ }^{\circ}\text{C}$, $P_{IN} = 0\text{ dBm}$, Characteristic Impedance = $50\text{ }\Omega$, Unless Otherwise Noted)

Parameter	Symbol	Test Condition	Min	Typical	Max	Units
Insertion loss	IL	0.02 to 0.5 GHz		0.40	0.50	dB
		0.5 to 1.0 GHz		0.45	0.50	dB
		1.0 to 2.0 GHz		0.50	0.60	dB
		2.0 to 2.7 GHz		0.60	0.70	dB
Isolation	Iso	0.02 to 0.5 GHz	28	30		dB
		0.5 to 1.0 GHz	22	24		dB
		1.0 to 2.0 GHz	17	22		dB
		2.0 to 2.7 GHz	15	19		dB
Return loss (insertion loss state)	S11	0.02 to 2.7 GHz		18		dB
Switching characteristics:		0/90% or 90/10% RF		60		ns
Rise/fall		50% control to 90/10% RF		100		ns
On/off		$T_{RSE} = 1\text{ ns}$, bandwidth = 500 MHz		50		mV
0.1 dB Input Compression Point	IP0.1dB	@ 48 MHz		+33.9		dBm
		@ 900 MHz		+37.0		dBm
2 nd and 3 rd harmonics	2fo, 3fo	$P_{IN} = +34.5\text{ dBm}$ @ 900 MHz		-65		dBc
Thermal resistance				25		$^{\circ}\text{C/W}$
Control voltage:			0		2.5	V
Low (@ 20 μA max)	V_{CTL_L}				5.0	V
High (@ 100 μA max)	V_{CTL_H}					V
High (@ 200 μA max)	V_{CTL_H}					V

Note 1: Performance is guaranteed only under the conditions listed in this Table.

Typical Performance Characteristics

($V_{CTL} = 0-3\text{ V}$, $T_{OP} = +25\text{ }^{\circ}\text{C}$, $P_{IN} = 0\text{ dBm}$, Characteristic Impedance [Z_0] = $50\text{ }\Omega$, $C_{BL} = 100\text{ pF}$, Unless Otherwise Noted)

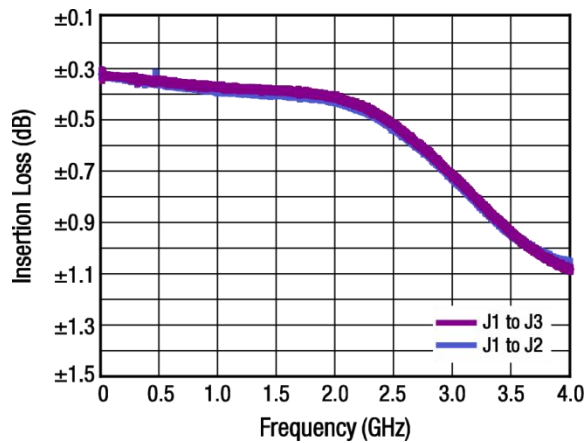

Figure 3. Insertion Loss vs Frequency

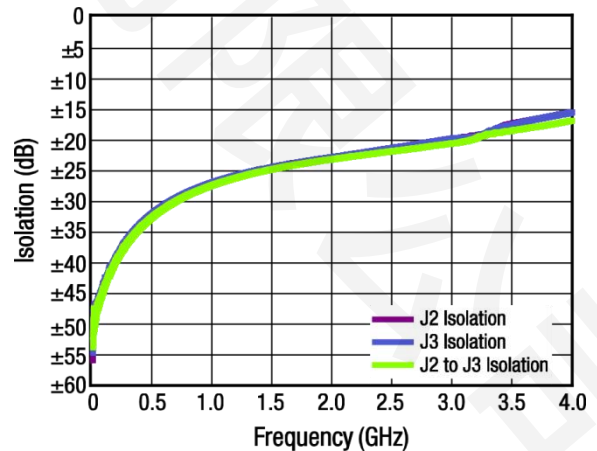

Figure 4. Isolation vs Frequency

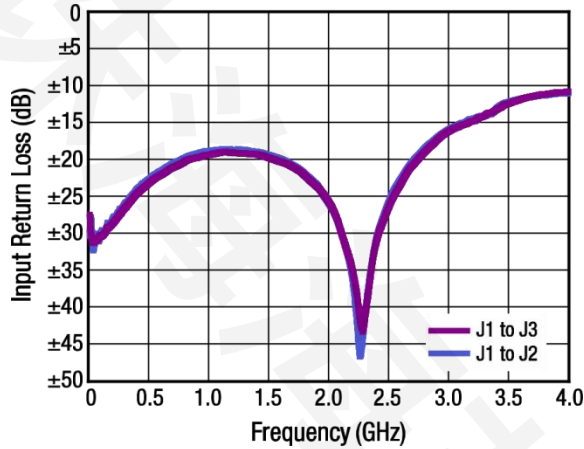

Figure 5. Input Return Loss (Insertion Loss State) vs Frequency

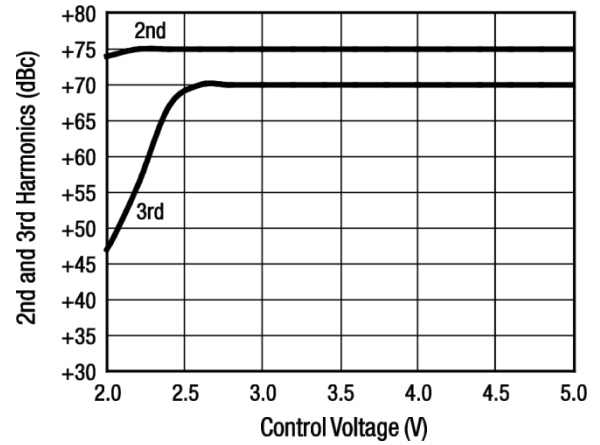

Figure 6. Second and Third Harmonics vs Control Voltage (Pin = +34.5 @ 900 MHz, GSM Signal)

Table 4. Truth Table (V_{HIGH} = 2 to 5 V)

V1	V2	J1~J2	J1~J3
V _{LOW}	V _{HIGH}	Isolation	Insertion loss
V _{HIGH}	V _{LOW}	Insertion loss	Isolation

Note: V_{LOW} = 0 to 0.2 V, V_{HIGH} = 2.5 to 5.0 V. Any state other than described in this Table places the device in an undefined state. An undefined state does not damage the device.

Evaluation Board Description

The SKY13270-92LF-HX Evaluation Board is used to test the performance of the SKY13270-92LF-HX SPDT switch. An Evaluation Board schematic diagram is provided in Figure 7. An assembly drawing for the Evaluation Board is shown in Figure 8.

Package Dimensions

Typical case markings are shown in Figure 9. Package dimensions for the 6-pin SC-70 are shown in Figure 10, and tape and reel dimensions are provided in Figure 11.

Package and Handling Information

Instructions on the shipping container label regarding exposure to moisture after the container seal is broken must be followed. Otherwise, problems related to moisture absorption may occur when the part is subjected to high temperature during solder assembly.

The SKY13270-92LF-HX is rated to Moisture Sensitivity Level 1 (MSL1) at 260 °C. It can be used for lead or lead-free soldering. Care must be taken when attaching this product, whether it is done manually or in a production solder reflow environment.

Production quantities of this product are shipped in a standard tape and reel format.

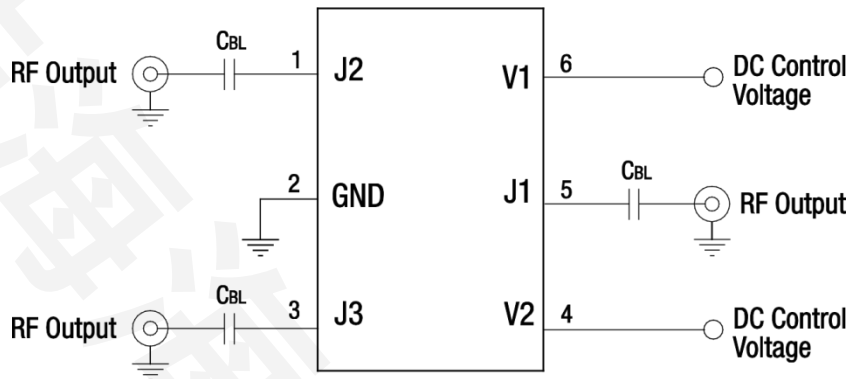

*Note: Use 100 pF blocking capacitors (CBL) for >500 MHz operation. Higher values recommended for lower frequency operation. Exposed paddle must be grounded.
Use 10 nF blocking capacitors (CBL) for <50 MHz operation.*

Figure 7. SKY13270-92LF-HX Evaluation Board Schematic

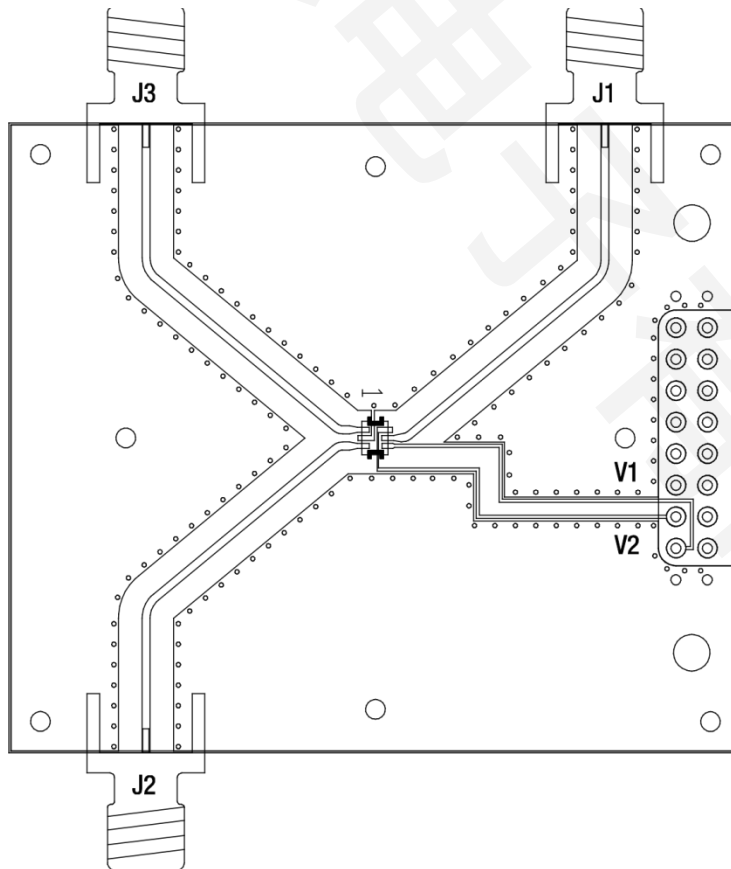
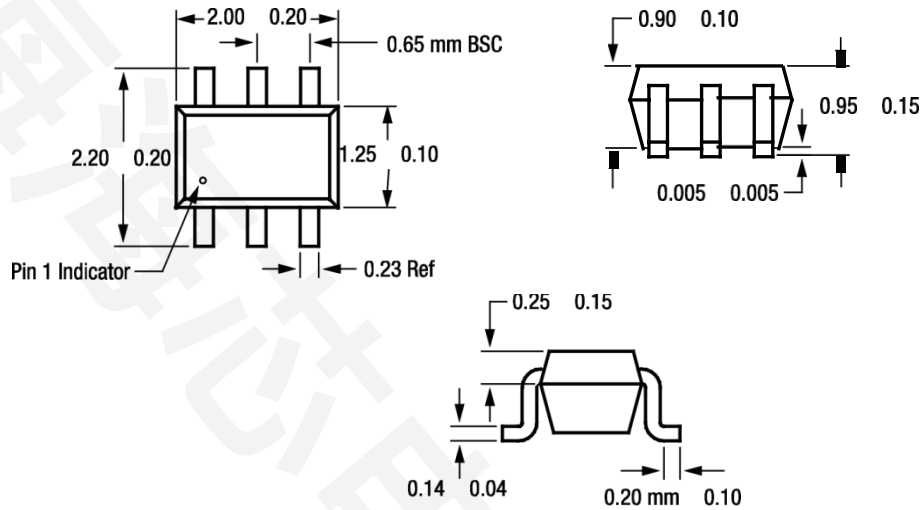

Figure 8. SKY13270-92LF-HX Evaluation Board Assembly Diagram

DIMENSIONAL DRAWINGS

SC-70



All measurements are in millimeters

Dimensioning and tolerancing according to ASME Y14.5M-1994

Figure 9. SKY13270-92LF-HX 6-Pin SC-70 Package Dimensions