

Typical Performance

- Ultra wide range input (2:1), output 10W
- Isolation voltage 1500Vdc
- Standby Power Loss: 0.3W(Typ)
- Ultra fast startup: 100ms(Typ)
- Working temperature: -40°C~+85°C
- Output short circuit, overcurrent protection
- Metal case, output low ripple
- Conversion efficiency 86%(Typ)
- International standard pin, PCB board in-line mounting

10W, Ultra Wide Voltage ,
Isolated Voltage Regulator Single/Dual Channel, DIP Package,
DC-DC Power Module



RoHS

VR(A)B_LD-10WR3 series products output power of 10W, 2:1 wide voltage input range, efficiency up to 86%, 1500VDC conventional isolation voltage, allowable operating temperature -40°C to +85°C, with output overcurrent, short circuit protection function, widely used in medical, industrial control, electric power, instrumentation, communication, railway and other fields

Product Coding Rules

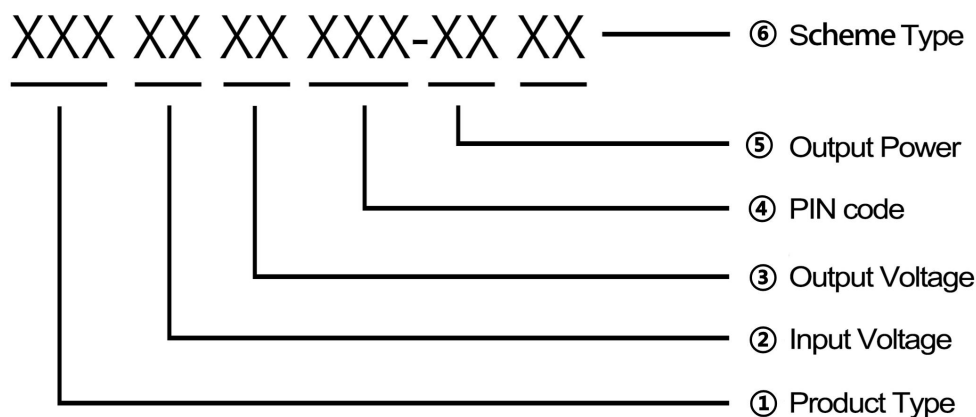

Product Selection Table

Certification	Model ^①	Input voltage range (Vdc)		Output voltage/current		Ripple and noise	Maximum capacitive load	Efficiency @ full load
		Nominal value ^② (range value)	Maximum	Output voltage (Vdc)	Output current (mA) (Max./Min.) Max./Min.	Full load (mVp-p) (TPY/Max.)	μF Max.	% (Min/TPY)
	VRB1203LD-10WR3	12	25	3.3	2000/0	50/80	4700	75/77
	VRB1205LD-10WR3	(9~18)		5	2000/0	50/80	2200	76/78

VRB1212LD-10WR3			12	833/0	50/80	1500	80/82
VRB1215LD-10WR3			15	666/0	50/80	1000	81/83
VRB1224LD-10WR3			24	416/0	50/80	470	82/84
VRA1205LD-10WR3			±5	±1000/0	30/50	1000	76/78
VRA1212LD-10WR3			±12	±416/0	50/80	800	80/82
VRA1215LD-10WR3			±15	±333/0	50/80	470	81/83
VRA1224LD-10WR3			±24	±208/0	50/80	220	82/84
VRB2403LD-10WR3			24 (18~36)	40	3.3	2000/0	50/80
VRB2405LD-10WR3	5	2000/0			50/80	2200	76/78
VRB2412LD-10WR3	12	833/0			50/80	1500	81/83
VRB2415LD-10WR3	15	666/0			50/80	1000	83/85
VRB2424LD-10WR3	24	416/0			50/80	470	84/86
VRA2405LD-10WR3			±5	±1000/0	50/80	1000	76/78
VRA2412LD-10WR3			±12	±416/0	50/80	800	81/83
VRA2415LD-10WR3			±15	±333/0	50/80	470	83/85
VRA2424LD-10WR3			±24	±208/0	50/80	220	84/86
VRB4803LD-10WR3	48 (36-72)	80	3.3	2000/0	50/80	4700	75/77
VRB4805LD-10WR3			5	2000/0	50/80	2200	76/78
VRB4812LD-10WR3			12	833/0	50/80	1500	81/83
VRB4815LD-10WR3			15	666/0	50/80	1000	83/85
VRB4824LD-10WR3			24	416/0	50/80	470	84/86
VRA4805LD-10WR3			±5	±1000/0	50/80	1000	76/78
VRA4812LD-10WR3			±12	±416/0	50/80	800	81/83
VRA4815LD-10WR3			±15	±333/0	50/80	470	83/85
VRA4824LD-10WR3	±24	±208/0	50/80	220	84/86		
VRB1D03LD-10WR3	110 (72-144)	180	3.3	2000/0	50/80	4700	75/77
VRB1D05LD-10WR3			5	2000/0	50/80	2200	76/78
VRB1D12LD-10WR3			12	833/0	50/80	1500	81/83
VRB1D15LD-10WR3			15	666/0	50/80	1000	83/85
VRB1D24LD-10WR3			24	416/0	50/80	470	84/86
VRA1D05LD-10WR3			±5	±1000/0	50/80	1000	76/78
VRA1D12LD-10WR3			±12	±416/0	50/80	800	81/83
VRA1D15LD-10WR3			±15	±333/0	50/80	470	83/85
VRA1D24LD-10WR3			±24	±208/0	50/80	220	84/86

Test conditions: Unless otherwise specified, all parameters are measured at nominal input voltage, pure resistive rated load and 25°C room temperature.

Input Features

Project	Working conditions	Min.	Typ.	Max.	Unit	
Input current (full load/no load)	12VDC nominal input series	3.3V Output	--	714/25	733/42	mA
		5.0V Output	--	1067/2	1096/42	
		12.0V	--	845/25	867/42	

		15.0V	--	1003/25	10	
		24.0V	--	911/25	10	
	24VDC nominal input series	3.3V Output	--	357/13	36	
		5.0V Output	--	533/13	54	
		12.0V	--	423/13	43	
		15.0V	--	502/13	51	
		24.0V	--	455/13	50	
		48VDC nominal input series	3.3V Output	--	179/7	18
	5.0V Output		--	267/7	27	
	12.0V		--	212/7	21	
	15.0V		--	251/7	25	
	24.0V		--	228/7	14	
110VDC nominal input series	3.3V Output		--	78/3	80/	
	5.0V Output	--	116/3	11		
	12.0V	--	109/3	111		
	15.0V	--	209/3	21		
	24.0V	--	105/3	10		
Reflected ripple current	12VDC nominal input series		--	60	--	mA
	24VDC nominal input series		--	40	--	
	48VDC nominal input series		--	30	--	
	110VDC nominal input series		--	20	--	
Impulse voltage (Isec.max)	12VDC nominal input series		-0.7	--	30	VDC
	24VDC nominal input series		-0.7	--	50	
	48VDC nominal input series		-0.7	--	10	
	110VDC nominal input series		-0.7	--	20	
Start voltage	12VDC nominal input series		--	--	9	VDC
	24VDC nominal input series		--	--	18	
	48VDC nominal input series		--	--	36	
	110VDC nominal input series		--	--	72	
Input under-voltage protection	12VDC nominal input series		--	--	--	VDC
	24VDC nominal input series		--	--	--	
	48VDC nominal input series		--	--	--	
	110VDC nominal input series		--	--	--	
Start time	Nominal input voltage and constant resistance load		-	100	-	mS
Input filter type			PI Type			
Hot plug			Not support			
CNT (Ctrl) *	Module turned on		Ctrl dangling or TTL high level (3.5-12VDC)			
	Module turned off		Ctrl Connect to GND or low level (0-1.2VDC)			
	Input current at shutdown		-	0	1	mA

Note: * The voltage of the Ctrl control pin is relative to the input pin GND, this series of products does not have this function.

Output Features

Project	Working and testing conditions	+Vo1			-Vo2		
		Min.	Typ.	Max.	Min.	Typ.	Max.
Output load	Load percentage	0%	-	100%	0%	-	100%
Output voltage accuracy		-	±1.0%	±2.0%	-	±2.0%	±3.0%
Linear adjustment rate	Input voltage range	-	±0.2%	±0.5%	-	±1.5%	±2%
Load regulation	20%~100% rated load, Balance the load	-	±0.5%	±1%	-	±4.0%	±5.0%
Ripple & Noise	Pure resistive load, 20MHz bandwidth, peak-to-peak	-	50 mVp-p	80 mVp-p	-	50 mVp-p	80 mVp-p
Turn on delay time		-	100ms	-	-	100ms	-
Output current voltage	Input voltage range	-	No adjustment end	-	-	No adjustment end	-
Dynamic response step deviation	25% nominal load step	-	±3.0%	±5.0%	-	±3.0%	±5.0%
Dynamic response recovery time		-	300μs	500μs	-	300μs	500μs
Output over voltage protection	Full voltage range input	-	-	-			
Output over-current protection	Full voltage range input	110%Io	150%Io	200%Io			
Output short circuit protection	Full voltage range input	Sustainable, self-healing					

Note: ① For product models with output voltage of ±5VDC and ±9VDC, the maximum accuracy of output voltage is ±5% under the condition of 0% to 5% load;

② According to 0%-100% load working conditions test, load adjustment rate index is ±5%;

③ 0%-5% load ripple & noise is less than or equal to 5%Vo. Test methods for ripple and noise The twisted pair test method can add capacitive load at the output end to reduce light load ripple

General Characteristics

Project	Working conditions	Min	Typ.	Max.	Unit
Insulation voltage	Input-output, test time:1m, leakage current < 1mA	150	--	--	VDC
Insulation resistance	Input-output, isolation voltage: 500VDC	100	--	--	MΩ
Isolation capacitance	Input-output, 100KHz/0.1V	--	1000	--	pF
Working temperature	Use the reference temperature derating curve diagram	-40	--	+85	°C
Storage temperature		-40	--	+125	

Shell temperature rise		--	--	+100	
Storage humidity	No condensation	5	--	95	%RH
Pin soldering	The solder joint is 1.5mm away from the shell, 10s	--	--	+300	°C
Switching frequency	PWM mode	--	250	--	KHz
Vibration		10-55Hz,10G,30Min.alongX,YandZ			
Shell material		Aluminum alloy shell			
Minimum time between failures	MIL-HDBK-217F@25°C	--	2X10 ⁵	--	Hrs

Product Characteristics Curve

Temperature Derating Curve

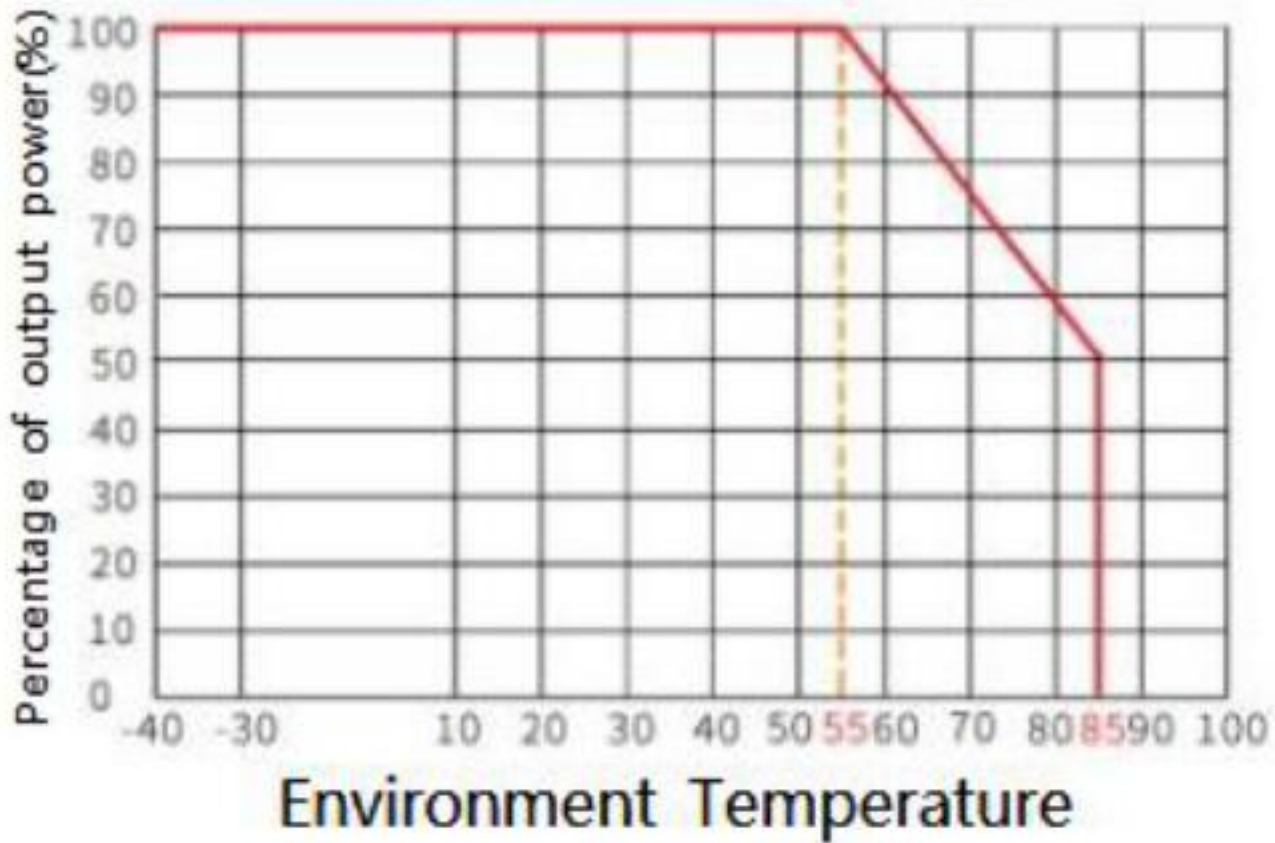

Reference Design

1、 Recommended test circuit

Generally recommended capacitors: C1: 47-100 μ F; C2、 C3: 10-22 μ F。

All DC/DC converters of this series are tested in accordance with the recommended test circuit (FIG. 1) before they are shipped.

If the input and output ripple is required to be further reduced, the input and output external capacitors C1, C2 and C3 can be increased or the capacitors with small series equivalent impedance value can be selected, but the capacitance value cannot be greater than the maximum capacitive load of the product.

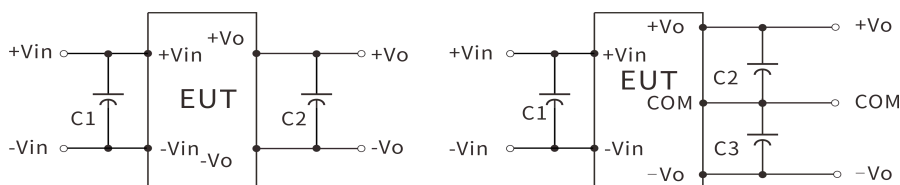
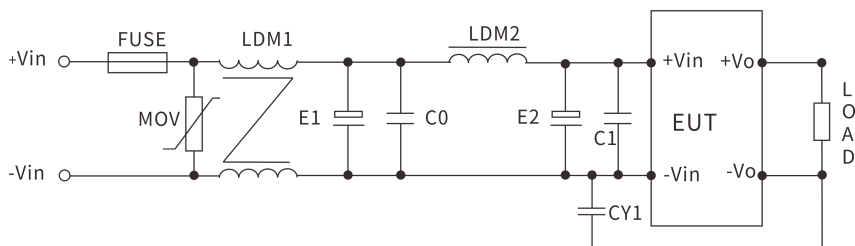

Figure 1

2、 EMC solutions -- Recommended circuits



Parameter Recommendation :

Device code	12V input product	24V input product	48V input product	110V input product
FMSE fuse	Connect the corresponding fuse according to customer's requirement			
MOV varistor	14D330K	14D560K	14D101K	14D201K
LDM1 common mode inductor	2mH	10mH	15mH	30mH
E1、 E2 electrolytic capacitors	470 μ F/50V	220 μ F/50V	100 μ F/100V	63 μ F/200V
C0, C1 ceramic capacitors	1 μ F/50V	1 μ F/50V	1 μ F/100V	0.47 μ F/250V
LDM2 differential mode inductance	4.7 μ H	10 μ H	15 μ H	68 μ H
CY1 safety gauge Y2 capacitance		1nF/250Vac		

3、 Output filtering peripheral recommended circuit

When the requirements of ripple and noise are general, it is recommended to use C2 and C5 only. When the requirements of ripple and noise are strict; The circuit above is recommended.

Positive and negative dual output products

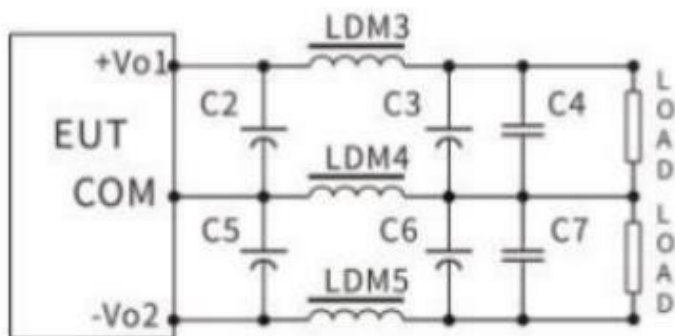

Single output product

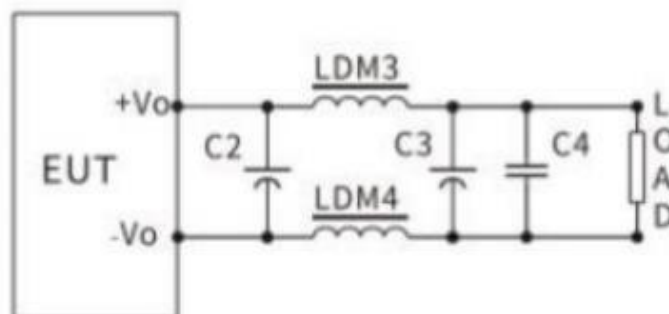

Note: 1. C2, C3, C5 and C6 use high frequency and low resistance electrolytic capacitors, and the total capacity shall not exceed the maximum capacitive load marked in the manual; otherwise, the module will fail to start normally.

2. When the capacitive load is applied, the minimum load of 3% must be ensured; otherwise, the module output will be abnormal.

3. LDM5 is only used for double output products

Parameter Recommendation :

Device code	3.3 V output	±5V or 5V output	±9V/12V or 9V/12V output	±15V or 15V output	±24V or 24V output
LDM3 inductance	0.47μH	1μH	2.2μH	2.2μH	4.7μH
LDM4 inductance	0.47μH	1μH	2.2μH	2.2μH	4.7μH
LDM5 inductance	-	1μH	2.2μH	2.2μH	4.7μH
C2、C3 electrolytic capacitor	220μF	220μF	100μF	100μF	68μF
C5、C6 electrolytic capacitor	220μF	220μF	100μF	100μF	68μF
C4、C7 electrolytic capacitor	1μF/50V				

3、Ripple & noise test :(twisted pair method 20MHZ bandwidth)

Test method:

1. Ripple noise is connected by 12# twisted pair wire, oscilloscope bandwidth is set as 20MHz, 100M bandwidth probe, and 0.1uF polypropylene capacitor and 47uF high frequency and low resistance electrolytic capacitor are connected in parallel on the probe end.

Sample sampling mode is used for oscilloscope sampling.

2. Schematic diagram of output ripple noise test:

The power input is connected to the input power supply and the power output is connected to the electronic load via the jig board. The test is directly sampled from the power output port with a 30cm±2cm sampling line alone. Power line according to the size of the output current to select the corresponding wire diameter of the insulated leather wire.

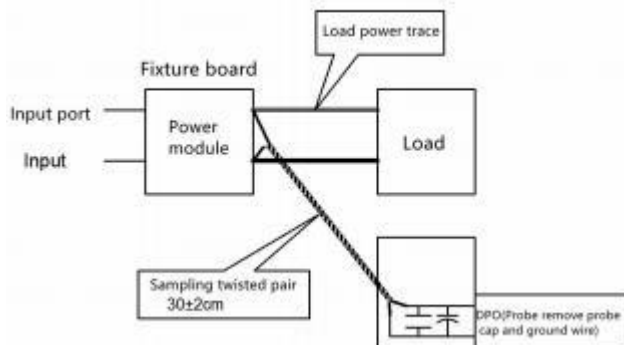

Package Size and Pin Function Diagram

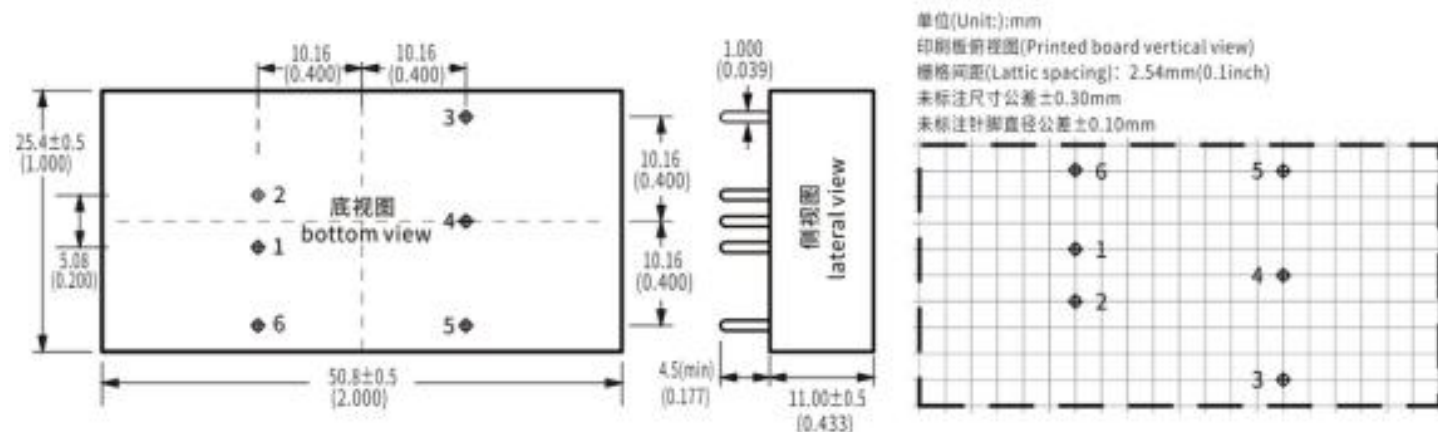

Single(S)	1	2	3	4	5	6
	-Vin	+Vin	+Vo	Trim	GND	NC
Dual(D)	Input negative	Input positive	Output positive	Voltage regulator end	Output ground	No contact
	-Vin	+Vin	+Vo1	COM	-Vo2	NC
	Input negative	Input positive	Output positive1	Commons	Output negative 2	No contact

* Note: If the pin definition of the power module is not consistent with the selection manual, the label on the object shall prevail.

Package Description

Package code	LxWxH	
B1	50.8X25.4X11.0mm	2.000X1.000X0.433inch

Contact

Shenzhen Hi-Link Electronic Co.,Ltd

Add: 17th Floor, Building E, Xinghe WORLD, Minle Community, Minzhi Street, Longhua District, Shenzhen, Guangdong, China 518131

Website: www.hlktech.com

E-mail: sales@hlktech.com

Tel: 0755-23152658