

# **SX1268SXXXN0S1 Wireless Module Hardware Specifications**

**V1.1**

## Content

1. Overview .....	1
2. Electrical Characteristics .....	3
3. Pin Diagram .....	4
4. Pin Description .....	5
5. Hardware design guide .....	6
5.1. Application circuit .....	6
5.2. Power supply design .....	6
5.3. Antenna design and selection .....	7
6. Programming development .....	10
7. Reflow Profile .....	11
8. ESD Notice .....	11
9. Packaging information .....	12
Mechanical Dimensions (unit:mm) .....	12
10. Revision History .....	13
11. Ordering Information .....	13
12. Statement .....	13
13. Contact us .....	14

## 1. Overview

SX1268SXXXN0S1 series wireless module, based on SEMTECH's SX1268 high-performance wireless transceiver chip design, is a compact, low-power, long-distance two-way wireless transceiver module.

SX1268 sub -GHz wireless transceiver is ideal for long-range wireless applications. 4.2mA of effective receive current, designed for battery powered applications. Built-in high efficiency power amplifier up to +22 dBm. The modules can support LoRa® modulation for LPWAN use cases and (G)FSK modulation for traditional use cases, and are highly configurable with parameters to meet different application requirements in industrial and consumer markets. The LoRa® modulation method is compatible with the technical specifications published by the LoRaWAN Alliance. Applicable to systems that comply with radio regulations, including but not limited to Chinese regulatory requirements and ETSI EN 300 220 (434 MHz) , its continuous frequency coverage from 410MHz to 810MHz supports low-power short-range devices in the 490MHz band and 780MHz band suitable for China.

The module integrates all RF-related functions and devices. Users can use this module to easily develop wireless solutions and wireless IoT devices with stable performance and high reliability without in-depth understanding of RF circuit design.

### Features:

- Supports LoRa and (G) FSK modems
- High link budget: 162 dB maximum link budget
- High output power: up to +22 dBm output power
- Low power consumption: low receive current less than 5 mA
- Two power modes, DC-DC and LDO
- LORA mode is programmable from 0.091 kbps to 62.5 kbps
- High sensitivity: as low as -140 dBm

## **Applications:**

- Smart meter reading
- Supply Chain and Logistics
- Building automation
- Agricultural sensor
- Smart City
- Retail store sensor
- Asset tracking
- Street light
- Parking sensor
- Environmental sensor
- Medical insurance
- Safety and Security Sensors
- Remote control application

## 2. Electrical Characteristics

Parameter	Description	Remark
Power Supply	1.8 ~ 3.7V	Typically 3.3V
Frequency Bands	433MHz / 490MHz	Frequency band is determined by the specific module model
Output Power	- 3dBm to + 22dBm	Programmable with steps
Data Rate	0.6kbps ~ 300Kbps@FSK 0.091kbps ~ 62.5kbps@LoRa	Programmable
Crystal Frequency	32MHz	±10ppm Crystal
RF Modulation	LORA, (G) FSK	Recommend LORA
Receive Sensitivity	-137dBm	LORA modulation , BW =125kHz, SF =12
Receive Bandwidth	4.8kHz ~ 467kHz/FSK 62.5kHz , 125kHz , 250kHz , 500kHz / LoRa	Programmable
TX Current	107 mA	TX Power = + 22dBm
RX Current	4.2mA	DC-DC mode
Sleep Current	<1uA	
driver interface	SPI	Standard 4-wire SPI, SPI clock: <=10MHz CPOL = 0, CPHA = 0
Antenna Impedance	50 ohms	
Antenna connection	stamp hole	
Storage Temperature	-55°C ~ + 125°C	
Operating Temperature	-40°C ~ + 85°C	Industrial grade
Size	11.5x11.5mm	

### 3. Pin Diagram

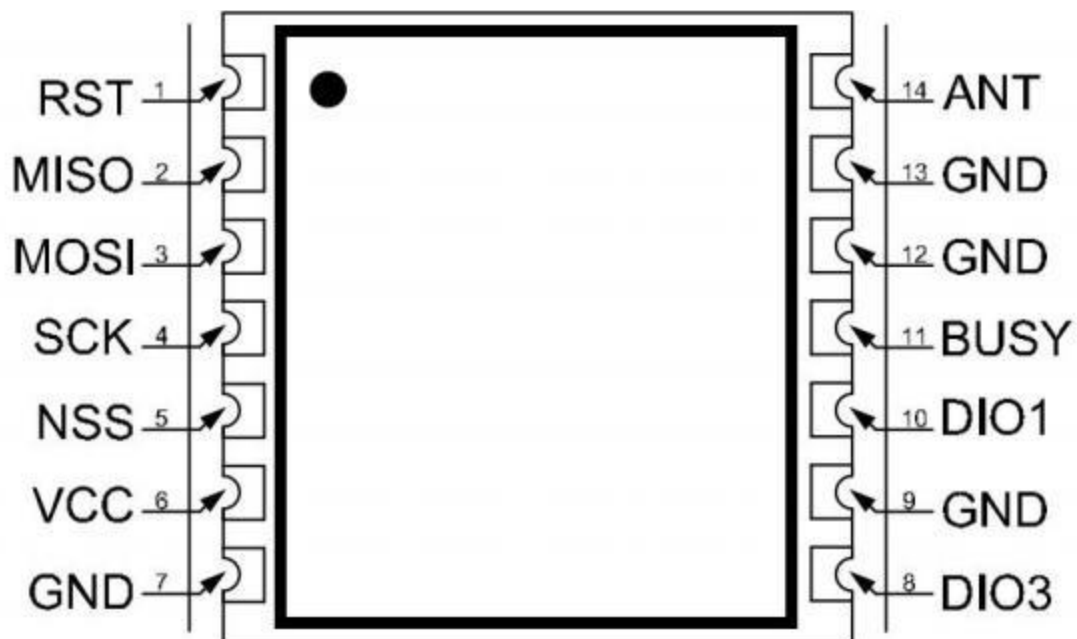

Figure 1-1 Top view

## 4. Pin Description

Number	Name	Type	Description
1	RST	I	Reset signal, active low
2	MISO	O	SPI interface MISO data output
3	MOSI	I	SPI interface MOSI data input
4	SCK	I	SPI interface SCLK clock input
5	NSS	I	SPI interface SPI chip select
6	VCC	power supply	Positive power supply
7	GND	power supply	Ground
8	DIO3	I/O	Directly connected to the chip DIO3 digital I/O pin, software configurable function
9	GND	power supply	Ground
10	DIO1	I/O	Directly connected to the chip DIO1 digital I/O pin, software configurable function
11	BUSY	O	Chip working status indication, busy status
12	GND	power supply	Ground
13	GND	power supply	Ground
14	ANT	I/O	RF signal input/output, connect to 50Ω antenna
...	DIO2	I/O	Directly connect the internal antenna switch of the module, call SetDio2AsRfSwitchCtrl(...) to set

## 5. Hardware design guide

### 5.1. Application circuit

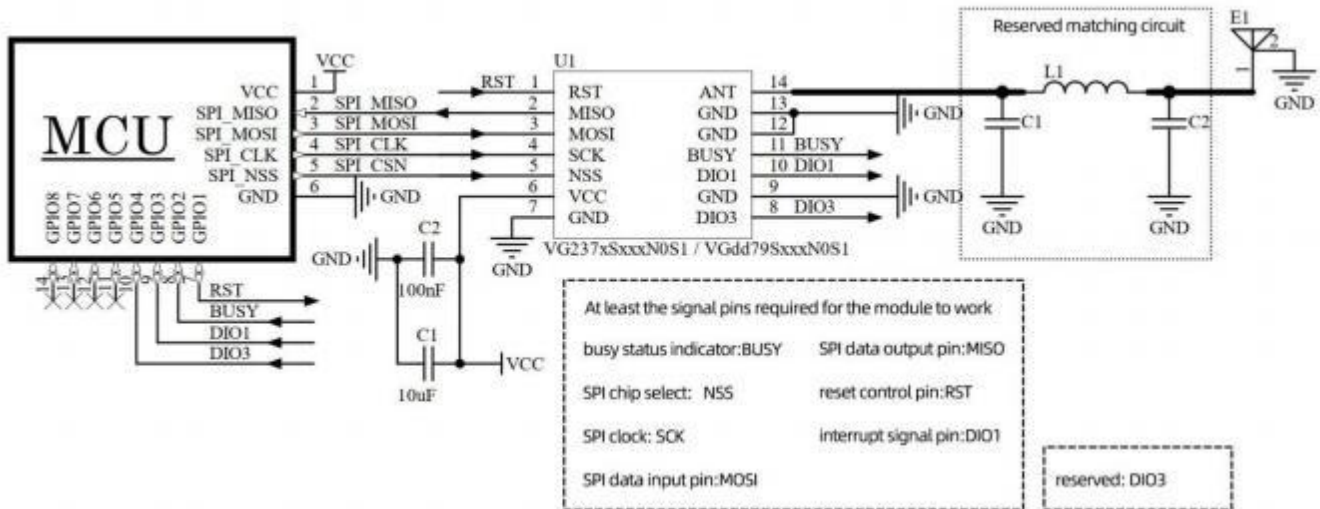

Figure 5-1 Programming development hardware connection

### 5.2. Power supply design

1. Please pay attention to the correct connection of the positive and negative poles of the power supply, and ensure that the power supply voltage is within the recommended power supply voltage range. If it exceeds the maximum allowable power supply range of the module, the module will be permanently damaged; the Coupling Capacitor of the module power supply pin should be as close as possible to the module power supply pin.

2. In the power supply system of the module, the excessive ripple may be coupled to the line that is easily interfered by the wire or the ground plane, such as the sensitive signal line such as the antenna, feeder, clock line, etc., which may easily cause the radio frequency performance of the module to deteriorate, LDO as the power supply for the wireless module is recommended.

3. When selecting the LDO voltage regulator chip, it is necessary to pay attention to the heat dissipation of the power supply and the driving capability of the LDO stable output current; considering the long-term stable operation of the whole machine, it is recommended to reserve more than 50% of the current output margin.

4. It is best to use a single LDO for the module to supply power; if a DC-DC power supply chip is used, an LDO must be added behind as the isolation of the module power supply to prevent the noise of the switching power supply chip from interfering with the working performance of the radio frequency.

5. If the communication line between the MCU and the module uses a 5V level, a 1K-5.1K resistor must be

connected in series ( not recommended, there is still a risk of damage ) .



6. The RF module should be kept away from high-voltage devices as far as possible, because the electromagnetic waves of high-voltage devices will also have a certain impact on the RF signal.

7. High-frequency digital wiring, high-frequency analog wiring, and high-current power supply wiring should be avoided under the module as much as possible. If it is necessary to pass under the module, the wiring should be placed on another layer of the PCB bottom plate where the module is placed, and ensure that it is under the module. The copper is well grounded.

## 5.3. Antenna Design and Guidance

### 5.3.1 Guidelies for bends in RF lines and RF trace

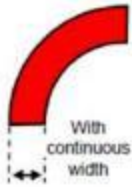
When the RF output interface of the module is selected in the form of a stamp hole, a 50ohm characteristic impedance trace is used to connect the antenna on the backplane PCB during design. Considering the attenuation of high-frequency signals, it should be noted that the length of the RF traces on the backplane PCB should be as short as possible. It is recommended that the longest trace length should not exceed 20 mm , and the trace width should be kept continuous; A bend is needed when there is a direction change for an RF line. Bends with RF lines can cause reflections and power loss. Some guidelines are detailed in this section to avoid issues with bends in high-frequency transmission lines.

Recommended	
Better	
Not good	

In order to ensure that the RF trace impedance of the backplane is 50 ohms, the following parameters can be adjusted according to different board thicknesses. The following simulation values are for reference only.

RF trace is 20mil	When board thickness is 1.0mm , the spacing between ground copper and traces is 5.3 mil
	When board thickness is 1.2mm , the spacing between ground copper and traces is 5.1 mil
	When board thickness is 1.6mm , the distance between ground copper and trace is 5mil
RF traces is 25mil	When thickness is 1.0mm , the distance between ground copper and trace is 6.3 mil
	When board thickness is 1.2mm , the distance between ground copper and trace is 6mil
	When board thickness is 1.6mm , the distance between ground copper and trace is 5.7 mil
RF traces is 30mil	When board thickness is 1.0mm , the distance between ground copper and trace is 7.6 mil
	When board thickness is 1.2mm , the distance between ground copper and trace is 7.1 mil
	When board thickness is 1.6mm , the distance between ground copper and trace is 6.6 mil

### 5.3.2 Internal Antenna

The built-in antenna refers to the antenna soldered on the PCB bottom plate and placed inside the product shell, including chip ceramic antenna, spring antenna, etc. When using the built-in antenna, the structure of the product and the installation position of the antenna have a great influence on the RF performance. Under the premise that the structure space of the product shell is sufficient, the spring antenna should be placed vertically upward as much as possible; Or the circuit board below the antenna can be hollowed out, because the metal has a very strong ability to absorb and shield RF signals, which will seriously affect the communication distance. In addition, the antenna should be placed on the edge of the bottom plate as much as possible.

### 5.3.3 External Antenna

External antenna refers to the antenna that the module is installed on the outside of the product casing through IPEX extension cable, SMA and other standard RF interfaces, including rod antenna, suction cup

antenna, fiberglass antenna, etc. The external antenna is basically a standard product. In order to better choose an antenna suitable for the module, in the process of antenna selection, the parameters of the antenna should be selected as follows:

1. The working frequency of the antenna should be consistent with the working frequency of the corresponding module.
2. The input characteristic impedance of the antenna should be 50ohm.
3. The interface size of the antenna should match the size of the antenna interface of the module.
4. The standing wave ratio (VSWR) of the antenna is recommended to be less than 2, and the antenna should have a suitable frequency bandwidth ( covering the frequency points used in the actual application of specific products ) .

### 5.3.4 Antenna matching

The antenna is critical to the transmission distance of the RF module. In practical applications, in order to facilitate the user's later antenna matching adjustment. It is recommended that users reserve a simple  $\pi$ -type matching circuit between the antenna and the ANT pin output of the module when designing the schematic diagram. If the antenna is already a standard  $50\Omega$ , the component L1 is attached with a 0R resistor, and the components C1 and C2 do not need to be soldered. Otherwise, you need to use a network analyzer to measure the actual impedance of the antenna and perform matching to determine the values of C1, L1, and C2. The trace from the ANT pin of the module to the antenna end should be as short as possible. It is recommended that the longest trace length should not exceed 20 mm .

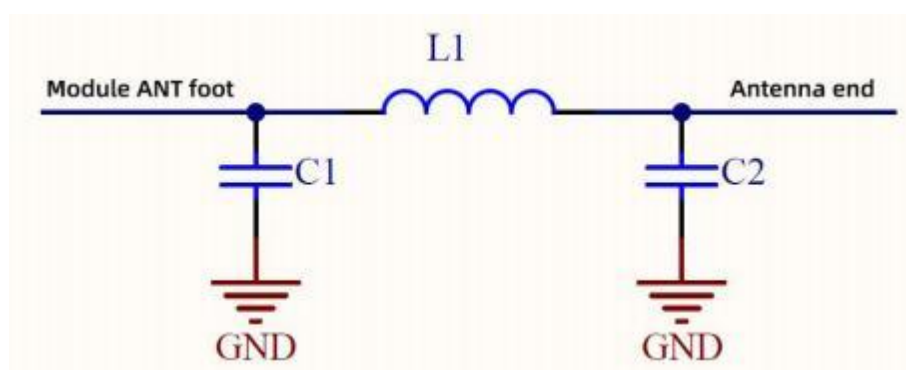

5-2  $\pi$ -type matching circuit

## 6. Programming development

The DIO2 pin of the RF chip has been used for the RF signal switch control driver inside the module. When programming the driver software, it is necessary to set the working state of DIO2, just call the function `SetDio2AsRfSwitchCtrl ( ... )`. During normal operation, the radio frequency chip will automatically switch the output signal of DIO2 according to the wireless working mode.

```

void SX126xInit( DioIrqHandler dioIrq )
{
    SX126xReset( );
    SX126xWakeup( );
    SX126xSetStandby( STDBY_RC );

#ifdef USE_TCXO
    CalibrationParams_t calibParam;

    SX126xSetDio3AsTcxoCtrl( TCXO_CTRL_1_7V, RADIO_TCXO_SETUP_TIME << 6 );
    calibParam.Value = 0x7F;
    SX126xCalibrate( calibParam );
#endif

    SX126xSetDio2AsRfSwitchCtrl( true );
    OperatingMode = MODE_STDBY_RC;
}
    
```

Generally, the receiving sensitivity of the RF chip is relatively poor at the integer multiple of its crystal oscillator operating frequency. It is recommended that users avoid the mirror frequency point of the module crystal oscillator when selecting the operating frequency, that is, the integer multiple of the crystal oscillator frequency. The crystal frequency of this module is 32MHz .

## 7. Reflow Profile

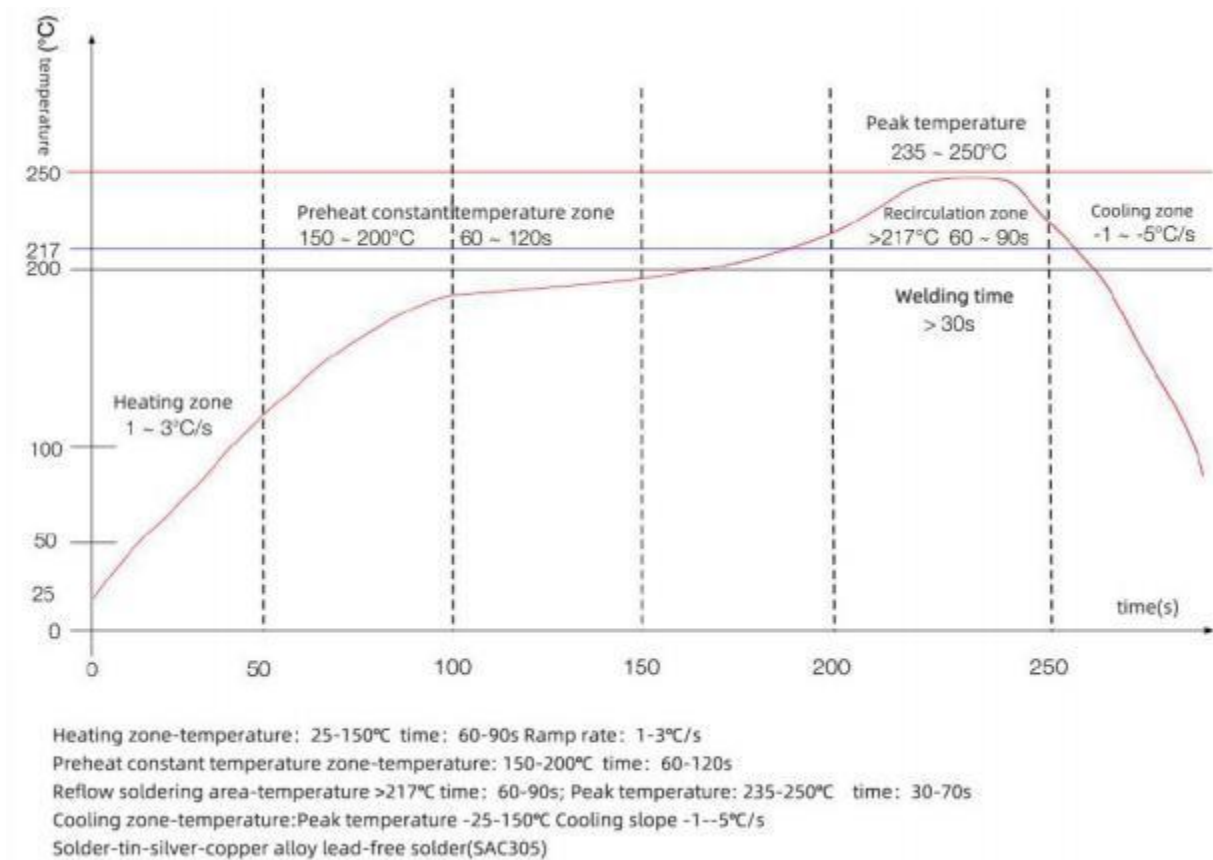

## 8. ESD Notice

The RF module is a high-voltage electrostatic sensitive device, in order to prevent damage to the module by static electricity

- 1、 Strictly follow anti-static measures, and do not touch the module with bare hands during production.
- 2、 Modules should be placed in a placement area that can prevent static electricity.
- 3、 The anti-static protection circuit at the high voltage input should be considered in product design.



## 9. Packaging information

### Mechanical Dimensions (unit:mm)

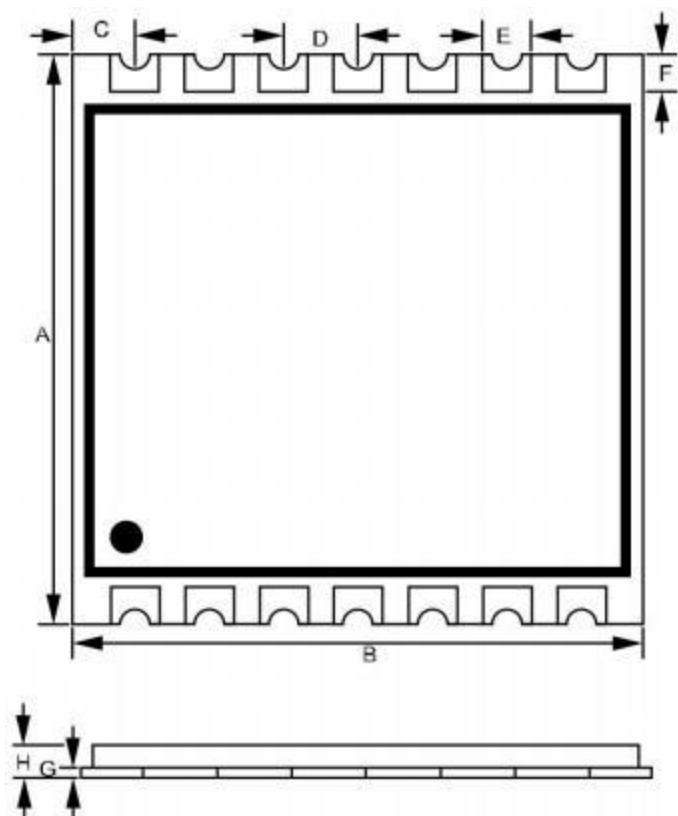

DIM	Dimensions (mm)	Tolerance (mm)
A	11.5	±0.5
B	11.5	±0.5
C	1.26	±0.1
D	1.5	±0.1
E	1.0	±0.1
F	0.65	±0.1
G	0.8	±0.1
H	2.2	±0.2

## 10. Revision History

Revision	Comment	Date
V1.0	First release	January 6, 2020
V1.1	Updated hardware design and related parameter descriptions	December 30, 2020

## 11. Ordering Information

Index	Part Number	Description
1	SX1268S433N0S1	433MHz frequency band,Tray \ Tape& Reel
2	SX1268S490N0S1	490MHz frequency band,Tray\ Tape& Reel

## 12. Statement

1. Due to product version upgrades or other reasons, the content of this document will be updated from time to time. Unless otherwise agreed, this document is only used as a guide, and the statements, information and recommendations in this document do not constitute any express or implied warranty.

2. The company reserves the right of final interpretation and modification of all the information provided, if any changes are made without prior notice.

## 13. Contact us

**Company:** Shenzhen Vollgo Technology Co., Ltd.

**Address:** Room 1411, Building A, Zhiyun Industrial Park, No. 13 Huaxing Road,  
Henglang Community, Dalang Street, Longhua District, Shenzhen, Guangdong

**Tel:** 0755-23040053

**Fax:** 0755-21031236

**Official website:** [www.vollgo.com](http://www.vollgo.com)

**Business cooperation:** [sales@vollgo.com](mailto:sales@vollgo.com)

