

Dwg. No. :H17-2846

承認字號

Issued Date: 2017/8/8

Customer : _____

(客戶)

Part No. : _____

(貴公司料號)

SPECIFICATION FOR APPROVAL

承認書

Description : Organic Conductive Polymer Aluminum Electrolytic Capacitors

(零件名稱)

Lelon Series : _____ OCV Series

(立隆系列)

Lelon Part No.: _____ OCV220M1VTR-0606

(立隆料號)

LELON ELECTRONICS CORP.

立隆電子工業股份有限公司

Headquarters

147, Sec. 1, Guoguang Rd., Dali District, Taichung, Taiwan
TEL: +886-4-24181856 FAX: +886-4-24181906

Manufacturing Sites



Lelon Electronics Corp.

147, Sec. 1, Guoguang Rd., Dali District, Taichung, Taiwan
TEL: +886-4-24181856 FAX: +886-4-24181906



Lelon Electronics (Huizhou) Co., Ltd.

Taiyang Industrial Zone, Baihua Town, Huidong County, Huizhou City,
Guangdong, China
TEL: +86-752-8768222 FAX: +86-752-8768199



Lelon Electronics (Suzhou) Co., Ltd.

1220, Zhongshan North Rd., Wujiang Economic and Technological Technological
Development Zone Suzhou City, Jiangsu, China
TEL: +86-512-63457588 FAX: +86-512-63457791

Approval Signatures

貴公司承認印

Approval 核准	Check 確認	Design 作成
		

Please Return One Copy with Your Approval

承認後請寄回本圖一份

Part Numbering System

Product Code Guide – SMD Type

OCV series	220 μ F	\pm 20%	6.3V	Carrier Tape		6.3 ϕ ×7L	Pb-free and PET coating case	
OCV	221	M	0J	TR	-	0607		
□□□	□□□	□	□□	□□	□	□□□□	□	
①	②	③	④	⑤	⑥	⑦	⑧	⑨
Series	Capacitance	Capacitance Tolerance	Rated Voltage	Package Type	Terminal Type	Case size	Lead Wire and Coating Type	Supplement Code

① Series:

Series is represented by a three-letter code. When the series name only has two letters, use a hyphen, "-", to fill the third blank. When the series name has 4 letters, use the following series codes.

OCVZ → OVZ; OCVU → OVU

② Capacitance:

Capacitance in μ F is represented by a three-digit code. The first two digits are significant and the third digit indicates the number of zeros following the significant figure. "R" represents the decimal point for capacitance under 10 μ F.

Example:

Capacitance	22	47	100	220	470	1,000	2,200	4,700
Part number	220	470	101	221	471	102	222	472

③ Tolerance:

K = -10% ~ +10%	M = -20% ~ +20%	V = -10% ~ +20%
-----------------	-----------------	-----------------

④ Rated voltage:

Rated voltage in volts (V) is represented by a two-digit code

Voltage (WV)	2.5	4	6.3	10	16	20	25	35	40	50	63
Code	0E	0G	0J	1A	1C	1D	1E	1V	1G	1H	1J

⑤ Package:

TR = Reel package

⑥ Terminal:

- = No dummy terminal

⑦ Case size:

The first two digits indicate case diameter and the last two digits indicate case length in mm.

ϕ D×L	5×5.7	6.3×4.4	6.3×5.9	6.3×7.0	6.3×7.7	8×6.7	8×12	10×7.7	10×9.9	10×12.6
Code	0506	0604	0606	0607	0608	0807	0812	1008	1010	1013

Note : When a case size is required and not shown in the table, please contact with us for further discussion.

⑧ Lead Wire and Coating Type:

None = Pb free wire + PET coating case (Standard design)

B = Sn-Bi Wire + Coating case

* When a supplement code following a blank digit code of lead wire and case coating type (standard design), use a hyphen, "-", to fill the blank digit.

* When the automotive control code is required, please contact with us for further discussion.

⑨ Supplement code (Optional):

For special control purpose

CUSTOMER :

CUSTOMER P/N:

PRODUCT DIMENSIONS

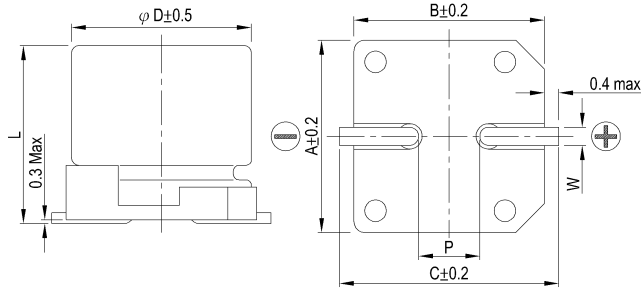

Unit: mm

ϕ D	6.3
L	5.9+0.1/-0.3
A	6.6
B	6.6
C	7.2
W	0.5-0.8
P	2.0 \pm 0.2

Items	Performance																		
Rated Voltage V_R	35 V																		
Capacitance C_R	22 μ F (120 Hz, 20°C)																		
Category Temperature Range	-55°C ~ +105°C																		
Capacitance Tolerance	-20 % ~ +20 % (120 Hz, 20°C)																		
Surge Voltage V_S	40.0 V_{DC}																		
Leakage Current (20°C)	$I_{LEAK} \leq 154 \mu$ A After 2 minutes																		
Tan δ	≤ 0.12 (120 Hz, 20°C)																		
ESR $_{max}$.	< 50 m Ω (100k ~300k Hz, 20°C)																		
Ripple Current ($I_{AC,R}$ / rms)	1300 mA (100k Hz, 105°C)																		
Ripple Current (mA) and Frequency Multipliers	<table border="1"> <thead> <tr> <th>Frequency (Hz)</th> <th>120 \leq f < 1k</th> <th>1k \leq f < 10k</th> <th>10k \leq f < 100k</th> <th>100k \leq f < 500k</th> </tr> </thead> <tbody> <tr> <td>Multiplier</td> <td>0.05</td> <td>0.3</td> <td>0.7</td> <td>1.0</td> </tr> </tbody> </table>	Frequency (Hz)	120 \leq f < 1k	1k \leq f < 10k	10k \leq f < 100k	100k \leq f < 500k	Multiplier	0.05	0.3	0.7	1.0								
Frequency (Hz)	120 \leq f < 1k	1k \leq f < 10k	10k \leq f < 100k	100k \leq f < 500k															
Multiplier	0.05	0.3	0.7	1.0															
Endurance and Moisture Resistance	<table border="1"> <thead> <tr> <th>Items</th> <th>Endurance</th> <th>Moisture Resistance</th> </tr> </thead> <tbody> <tr> <td>Test Time</td> <td>2,000 Hrs at 105°C; V_R</td> <td>1,000 Hrs at 60°C; 90 ~ 95% R. H.</td> </tr> <tr> <td>Cap. Change</td> <td>Within \pm20 % of initial value</td> <td>Within \pm20 % of initial value</td> </tr> <tr> <td>Tan δ</td> <td>Less than 150% of specified value</td> <td>Less than 150% of specified value</td> </tr> <tr> <td>ESR</td> <td>Less than 150% of specified value</td> <td>Less than 150% of specified value</td> </tr> <tr> <td>Leakage Current*</td> <td>Within specified value</td> <td>Within specified value</td> </tr> </tbody> </table>	Items	Endurance	Moisture Resistance	Test Time	2,000 Hrs at 105°C; V_R	1,000 Hrs at 60°C; 90 ~ 95% R. H.	Cap. Change	Within \pm 20 % of initial value	Within \pm 20 % of initial value	Tan δ	Less than 150% of specified value	Less than 150% of specified value	ESR	Less than 150% of specified value	Less than 150% of specified value	Leakage Current*	Within specified value	Within specified value
Items	Endurance	Moisture Resistance																	
Test Time	2,000 Hrs at 105°C; V_R	1,000 Hrs at 60°C; 90 ~ 95% R. H.																	
Cap. Change	Within \pm 20 % of initial value	Within \pm 20 % of initial value																	
Tan δ	Less than 150% of specified value	Less than 150% of specified value																	
ESR	Less than 150% of specified value	Less than 150% of specified value																	
Leakage Current*	Within specified value	Within specified value																	
Standards	JIS C 5101-25, IEC 60384-4																		
Remarks	RoHS Compliance, Halogen-free																		

* For any doubt about measured values, measure the leakage current again after the following voltage treatment.
Voltage treatment: Applying DC rated voltage to the capacitors for 2 hours at 105°C.

Marking: Each capacitor shall be marked with the following information.

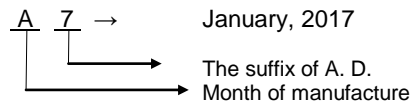
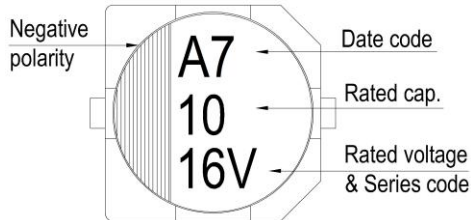

Month	1	2	3	4	5	6
Code	A	B	C	D	E	F
Month	7	8	9	10	11	12
Code	G	H	I	J	K	L

Marking color: Blue

* Please refer to "Precautions and Guidelines for Aluminum Electrolytic Capacitors" section in Lelon's catalog for further details.

Publication Date	August 8, 2017	Approval Signatures:	Approved	Checked	Designed
Revision Date					
Version No.	1		Please return one copy with your approval		

Diagram of Dimensions:

Unit: mm

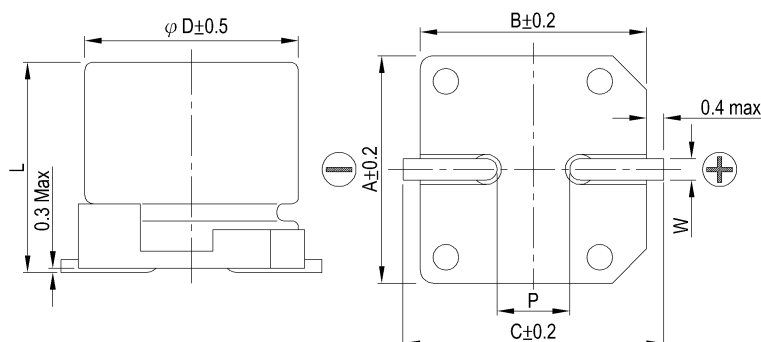

φD	L	A	B	C	W	P ± 0.2
5	5.7± 0.3	5.3	5.3	5.9	0.5 to 0.8	1.5
6.3	5.9+0.1/-0.3	6.6	6.6	7.2	0.5 to 0.8	2.0
6.3	7.0 ± 0.2	6.6	6.6	7.2	0.5 to 0.8	2.0
6.3	7.7 ± 0.3	6.6	6.6	7.2	0.5 to 0.8	2.0
8	6.7 ± 0.3	8.4	8.4	9.0	0.7 to 1.1	3.1
8	9.0 ± 0.5	8.4	8.4	9.0	0.7 to 1.1	3.1
8	12.0 ± 0.5	8.4	8.4	9.0	0.7 to 1.1	3.1
10	7.7 ± 0.3	10.4	10.4	11.0	0.7 to 1.3	4.7
10	9.9+0.1/-0.3	10.4	10.4	11.0	0.7 to 1.3	4.7
10	12.6 +0.1/-0.4	10.4	10.4	11.0	0.7 to 1.3	4.7

Marking:

Each capacitor shall be marked with the following information.

φD = 6.3 mm

φD = 8 ~ 10 mm

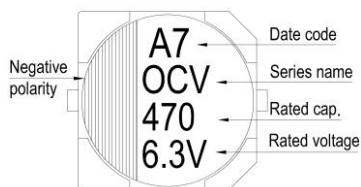
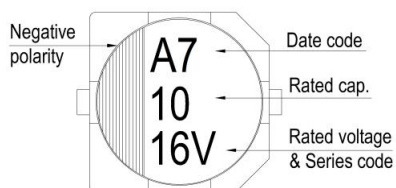

Description of Date Code:

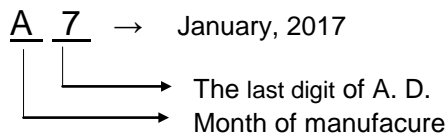

Month	1	2	3	4	5	6
Code	A	B	C	D	E	F
Month	7	8	9	10	11	12
Code	G	H	I	J	K	L

Origin Code:

Huizhou: A7 , B7 , ... , K7 , L7
Suzhou: 7A , 7B , ... , 7K , 7L

Marking Color: Blue

Taping Specification for SMD Type

1. Carrier Tape

Fig. 1-1

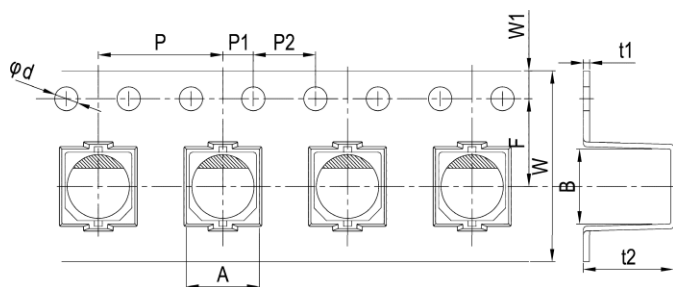

Fig. 1-2

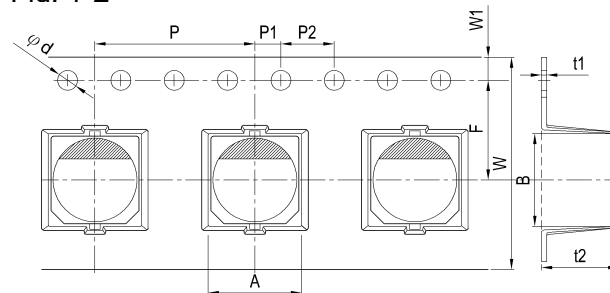
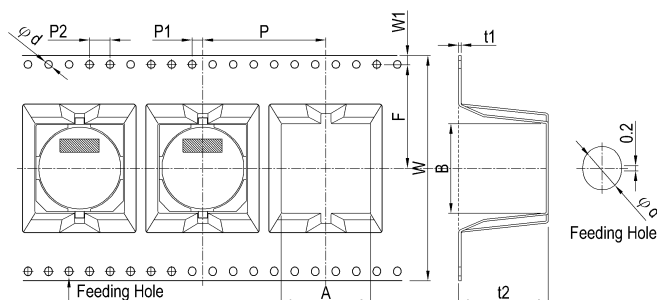

Fig. 1-3



Unit: mm

φD xL	A	B	φd	F	P	P1	P2	t1	t2	W	W1	Fig. No.
3~4 x4.5~5.3	4.7	4.7	1.5	5.5	8	2.0	4.0	0.4	5.8	12.0	1.75	1-1
4 x5.7	4.7	4.7		5.5	8				6.2			
5 x4.5~5.3	5.7	5.7		5.5	12				5.8			
5 x5.7 (5.9*)	5.7	5.7		5.5	12				6.2			
6.3 x4.5~5.3	7.0	7.0		7.5	12				5.8			
6.3 x5.7 / 5.8	7.0	7.0							6.2			
6.3 x5.9*	7.0	7.0							6.2			
6.3 x7.0*	7.0	7.0							6.8			
6.3 x7.7	7.0	7.0							8.3			
8 x6.5	8.7	8.7							6.8			
8 x6.7*	8.7	8.7	11.5	16	6.8							
8 x10	8.7	8.7			11.0							
8 x11.2 / 12*	8.7	8.7			13.0							
10 x7.7*	10.7	10.7			10.0							
10 x10 (9.9*)	10.7	10.7			11.0							
10 x12.6*	10.7	10.7			13.0							
12.5 x13.5	13.4	13.4	14.2	24	15.0							
12.5 x13.5(G)	13.7	13.7			15.0							
12.5 x16	13.4	13.4			17.5							
12.5 x16(G)	13.7	13.7			17.5							
16 x16.5	17.5	17.5			17.5							
16 x16.5(G)	17.5	17.5			17.5							
16 x21.5	17.5	17.5	20.2	28	22.5							
18 x16.5	19.5	19.5			17.5							
18 x21.5	19.5	19.5			22.5							
Tol.	±0.2	±0.2	+0.1/-0	±0.1	±0.1	±0.1	±0.1	±0.1	±0.2	±0.3	±0.15	

Note: Case size in mark of "*" are for OP-CAP ; case size in mark of "G" are for "Anti-vibration"

2. Reel Package

Fig. 2-1

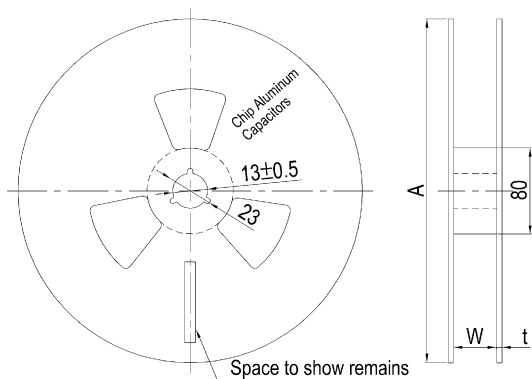
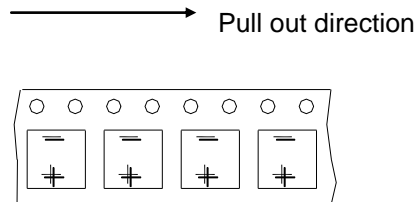

Fig. 2-2 Reel Polarity



Case size	3 ~ 4φ	5φ	6.3φ	8φ×6.5 ~ 7L	8φ×10 ~ 12L	10φ	12.5φ	16 ~ 18φ
W	14	14	18	18	26	26	34	46
A	380	380	380	380	380	380	380	380
t	3.0	3.0	3.0	3.0	3.0	3.0	3.0	3.0

3. Packing specification

Fig. 3-1 Carrier Tape

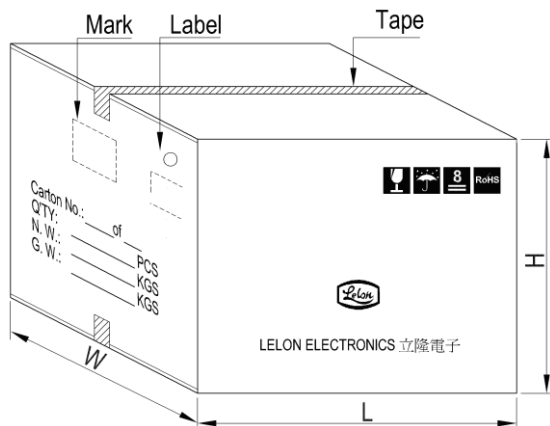

Unit: pcs

Case size	Q'ty / Reel	Q'ty / Box
3φ	2,000	20,000
4φ	2,000	20,000
5φ	1,000	10,000
6.3φ	1,000	10,000
8φ×6.5~7L	1,000	10,000
8φ×10L	500	5,000
8φ×12L*	400	4,000
10φ×8~10L	500	5,000
10φ×12.7L*	400	4,000
12.5φ×13.5L	200	1,600
12.5φ×16L	200	1,600
16φ×16.5L	200	1,600
16φ×21.5L	100	800
18φ×16.5L	150	1,200
18φ×21.5L	100	800

* Case size with "*" mark are for OP-CAP only.

Unit: mm

Case size	3 ~ 4φ	5φ	6.3φ	8φ× 6.5 ~ 7L	8φ× 10 ~ 12L	10φ	12.5φ	16 ~ 18φ
H	210	210	250	250	330	330	330	425
W, L	395	395	395	395	395	395	395	395

Fig. 3-2 Label

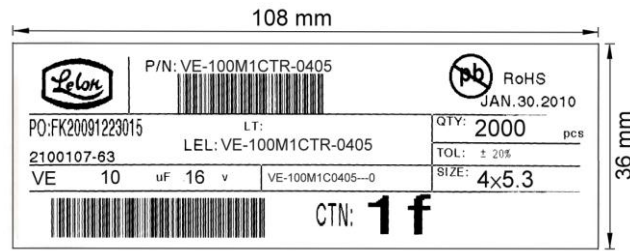

4. Chip Tray

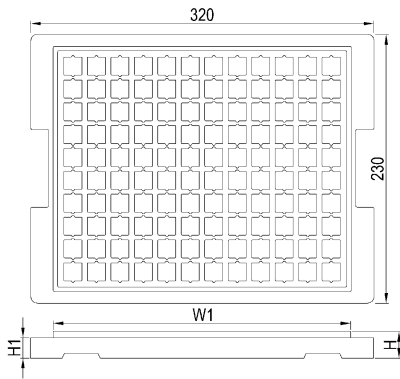

Dimension and package quantity Unit: mm

Case size	W1	H	H1	Q'ty / Tray	Q'ty / Box
12.5φ×13.5L	284	21	18.5	120	600
12.5φ×16L	284	21	18.5	120	600
16φ×16.5L	284	28	24.0	80	400
16φ×21.5L	284	28	24.0	80	400
18φ×16.5L	284	28	24.0	60	300
18φ×21.5L	284	28	24.0	60	300

5. Sealing Tape Reel Strength

- 5.1 Peel angle: 165 to 180°C referred to the surface on which the tape is glued.
- 5.2 Peel speed: 300mm per minutes
- 5.3 The peel strength must be 0.1 ~ 0.7N under these conditions.

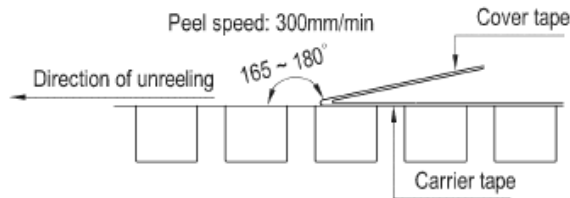

6. Packing Method

- 6.1 Polarity: Anode on the opposite side of the feed hole
- 6.2 The leader length of the tape shall not be less than 400mm including 10 or more embossed sections in which no parts are contained.
- 6.3 The winding core is provided with an over 40mm long empty section.

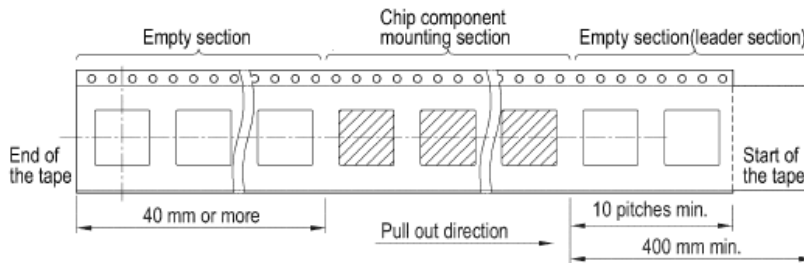

Endurance Characteristic:

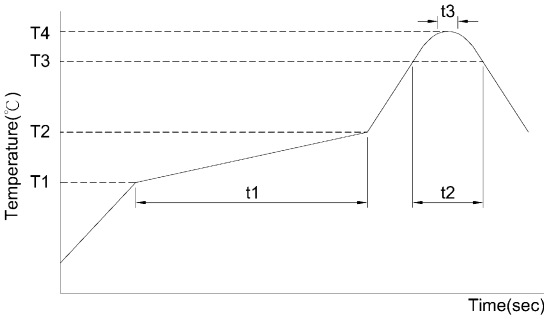
No.	Item	Conditions	Specification																										
1	Rotational Temperature Test	Capacitor is placed in an oven whose temperature follow specific regulation to change. The specific regulation is "+25°C (3 min.) → -55°C (30 min.) → +25°C (3min.) → +105°C (30 min.) → +25°C (3min.)", and it is called a cycle. The test totals 10 cycles. And then the capacitor shall be subjected to standard atmospheric conditions for 4 hours, after which measurements shall be made.	Capacitance change	Within ±10% of initial value.																									
			Tanδ	Within specified value																									
			Leakage Current	Within specified value																									
			Physical	No broken and undamaged																									
2	High Temperature Endurance Life Test	1. Capacitors shall be placed in oven with application of rated voltage for 2000 +72/-0 hrs at 105°C. 2. Then the capacitor shall be subjected to standard atmospheric conditions for 4 hours, after which measurements shall be made.	Capacitance change	Within ±20% of initial value																									
			Tanδ	Less than 150% of specified value																									
			Leakage Current	Within specified value																									
			ESR	Less than 150% of specified value																									
			Physical	No broken and undamaged																									
3	Moisture Resistance	Capacitors shall be exposed for 1000 +48/-0 hrs in an atmosphere of 90 ~ 95% R.H. at 60±3°C. And then the capacitor shall be subjected to standard atmospheric conditions for 4 hours, after which measurements shall be made.	Capacitance change	Within ±20% of initial value.																									
			Tanδ	Less than 150% of specified value																									
			Leakage Current	Within specified value																									
			ESR	Less than 150% of specified value																									
			Physical	No broken and undamaged																									
4	Vibration Test	1. Fix it at the point 4mm or less form body. For ones of 12.5mm or more in diameter or 25mm or more length, use separate fixture. 2. Direction and during of vibration: 3 orthogonal directions mutually each for 2 hrs (total of 6 hrs). 3. Frequency: 10 to 55 Hz reciprocation for 1min. 4. Total amplitude : 1.5mm	Capacitance change	Within ±10% of initial value																									
			Tanδ	Within specified value																									
			Leakage Current	Within specified value																									
			ESR	Within specified value																									
			Physical	No broken and undamaged																									
5	Resistance to Soldering Heat Test	IR Reflow  <table border="1" data-bbox="395 1568 909 1836"> <tr> <td rowspan="2">Preheat</td> <td>Temp.(T1~T2,°C)</td> <td colspan="2">150~200</td> </tr> <tr> <td>Time(t1)(Max,secs)</td> <td colspan="2">180</td> </tr> <tr> <td rowspan="2">Duration</td> <td>Temp. (T3,°C)</td> <td colspan="2">230</td> </tr> <tr> <td>Time(t2)(Max,secs)</td> <td colspan="2">60</td> </tr> <tr> <td rowspan="2">Peak</td> <td>Temp. (T4,°C)</td> <td>250</td> <td>260</td> </tr> <tr> <td>Time (t3,secs)</td> <td colspan="2">5</td> </tr> <tr> <td colspan="2">Reflow cycles</td> <td>2</td> <td>1</td> </tr> </table> <p>* Please contact our representative if your condition is higher. * Please ensure that the capacitor became coldenough to the room temperature (5°C ~ 35°C) before the second reflow. * Consult with us when performing reflow profile in IPC / JEDEC (J-STD-020)</p>	Preheat	Temp.(T1~T2,°C)	150~200		Time(t1)(Max,secs)	180		Duration	Temp. (T3,°C)	230		Time(t2)(Max,secs)	60		Peak	Temp. (T4,°C)	250	260	Time (t3,secs)	5		Reflow cycles		2	1	Capacitance change	Within ±10% of initial value.
				Preheat	Temp.(T1~T2,°C)	150~200																							
			Time(t1)(Max,secs)		180																								
			Duration	Temp. (T3,°C)	230																								
				Time(t2)(Max,secs)	60																								
			Peak	Temp. (T4,°C)	250	260																							
				Time (t3,secs)	5																								
			Reflow cycles		2	1																							
			Tanδ	Within specified value																									
			Leakage Current	Within specified value																									
ESR	Within specified value																												
Physical	No broken and undamaged																												

No.	Item	Conditions	Specification																																
6	Surge Voltage Test	The capacitor shall be subjected to 1000 cycles at 15~35°C. Protective series resistor a 1KΩ each consisting of a charge period of 30±5 seconds, followed by discharge period of approximately 5.5 minutes. Applying voltage: <table border="1" style="margin-left: 20px;"> <tr> <td>Rated Voltage(V)</td> <td>2.5</td> <td>4</td> <td>6.3</td> <td>10</td> <td>16</td> <td>20</td> <td>25</td> <td>35</td> <td>50</td> <td>63</td> </tr> <tr> <td>Surge Voltage(V)</td> <td>2.9</td> <td>4.6</td> <td>7.2</td> <td>12.0</td> <td>18.0</td> <td>23.0</td> <td>29.0</td> <td>40.0</td> <td>58.0</td> <td>73.0</td> </tr> </table>	Rated Voltage(V)	2.5	4	6.3	10	16	20	25	35	50	63	Surge Voltage(V)	2.9	4.6	7.2	12.0	18.0	23.0	29.0	40.0	58.0	73.0	<table border="1"> <tr> <td>Capacitance change</td> <td>Within ±20% of initial value.</td> </tr> <tr> <td>Tanδ</td> <td>Less than 150% of specified value</td> </tr> <tr> <td>Leakage Current</td> <td>Within specified value</td> </tr> <tr> <td>ESR</td> <td>Less than 150% of specified value</td> </tr> <tr> <td>Physical</td> <td>No broken and undamaged</td> </tr> </table>	Capacitance change	Within ±20% of initial value.	Tanδ	Less than 150% of specified value	Leakage Current	Within specified value	ESR	Less than 150% of specified value	Physical	No broken and undamaged
			Rated Voltage(V)	2.5	4	6.3	10	16	20	25	35	50	63																						
			Surge Voltage(V)	2.9	4.6	7.2	12.0	18.0	23.0	29.0	40.0	58.0	73.0																						
			Capacitance change	Within ±20% of initial value.																															
			Tanδ	Less than 150% of specified value																															
Leakage Current	Within specified value																																		
ESR	Less than 150% of specified value																																		
Physical	No broken and undamaged																																		
7	Thermal Shock Test	Capacitor is placed in an oven whose temperature follow specific regulation to change. The specific regulation is - 55 ± 3°C (30 min.) → +105 ± 3°C (30 min.), and it is called a cycle. The test totals 10 cycles.	<table border="1"> <tr> <td>Capacitance change</td> <td>Within ± 10% of initial value</td> </tr> <tr> <td>Tanδ</td> <td>Within specified value</td> </tr> <tr> <td>Leakage Current</td> <td>Within specified value</td> </tr> <tr> <td>ESR</td> <td>Within specified value</td> </tr> <tr> <td>Physical</td> <td>No broken and undamaged</td> </tr> </table>	Capacitance change	Within ± 10% of initial value	Tanδ	Within specified value	Leakage Current	Within specified value	ESR	Within specified value	Physical	No broken and undamaged																						
			Capacitance change	Within ± 10% of initial value																															
			Tanδ	Within specified value																															
			Leakage Current	Within specified value																															
			ESR	Within specified value																															
Physical	No broken and undamaged																																		
8	Mechanical Characteristics Test	Bending Test: Apply pressure in the direction of the arrow at a rate of about 0.5 mm / s until bent width reaches 2 mm and hold for 60s. The board shall be the test board "B" as specified in JIS C 0051: 2002. If the land area differs, it shall be specified clearly in the next item.	Without mechanical damage such as breaks. Electrical characteristics shall be satisfied. If there are electrodes on both surfaces, above requirements shall be satisfied on whichever surface it may be fixated on.																																
9	Solderability Test	After the lead wire fully immersed in the solder for 2±0.5 secs at a temperature of 245±5°C, the solder coating must be more than 95%.																																	
10	Failure Rate Level	Examination of resistance to solder heat. Test temperature : 105±3°C Applied voltage: Apply D.C. voltage equal to rated voltage. Confidence level: 60 %																																	
11	Coating Case	The color of coating case will turn light khaki from colorless with long duration in high temperature. Should there is any concern with the color changing of coating case, please consult with us.																																	
12	Land Pattern	Recommended pad pattern and size 	<table border="1"> <thead> <tr> <th rowspan="2">Case size</th> <th colspan="3">Land size</th> </tr> <tr> <th>a</th> <th>b</th> <th>c</th> </tr> </thead> <tbody> <tr> <td>4φ</td> <td>1.0</td> <td>2.6</td> <td>1.6</td> </tr> <tr> <td>5φ</td> <td>1.4</td> <td>3.0</td> <td>1.6</td> </tr> <tr> <td>6.3φ</td> <td>1.9</td> <td>3.5</td> <td>1.6</td> </tr> <tr> <td>8φ</td> <td>3.0</td> <td>3.5</td> <td>2.5</td> </tr> <tr> <td>10φ</td> <td>4.</td> <td>4.0</td> <td>2.5</td> </tr> </tbody> </table>	Case size	Land size			a	b	c	4φ	1.0	2.6	1.6	5φ	1.4	3.0	1.6	6.3φ	1.9	3.5	1.6	8φ	3.0	3.5	2.5	10φ	4.	4.0	2.5					
			Case size		Land size																														
a	b	c																																	
4φ	1.0	2.6	1.6																																
5φ	1.4	3.0	1.6																																
6.3φ	1.9	3.5	1.6																																
8φ	3.0	3.5	2.5																																
10φ	4.	4.0	2.5																																
13	Standards	Satisfies Characteristic JIS C 5101-25																																	
14	Remarks	OP-CAP is appropriate for the products of non-concussive environment, if it needs to be applied on concussive environment, we suggest that the capacitors should be fixed by glue and it cannot exceed the condition of concussive spec.																																	

Precautions and Guidelines for Organic Conductive Polymer Aluminum Capacitors

Organic conductive polymer capacitor (OP-CAP) is specially structured using with a solid electrolyte of conductive polymers, has several advantages over non-solid aluminum capacitors due to its compact size, wide operation temperature range, high resistance against ripple current, and especially, low ESR. The only disadvantage, however, is their low working voltage. Over past few years, Lelon has developed a number of series of OP-CAPs. Please refer to following guidelines for obtaining the highest performance and stable quality by using OP-CAP series products.

1. Guidelines for Circuit design

(1) Polarity

OP-CAPs are basically nothing but aluminum electrolytic capacitors with solid electrolyte. Therefore, they must be installed with the correct polarity. Usage in the reverse polarity results into a short-circuit condition that may damage or even explode the capacitor.

In addition, it may affect circuit functionality.

(2) Operating Voltage

Applied DC voltage must not exceed rated voltage of an OP-CAP. Applying higher voltage across a capacitor terminals than its rated voltage will cause overheating due to higher leakage currents, and dielectric/insulation deterioration that will ultimately affect a capacitor's performance. The OPCAP, however, is capable of working under short-time transient voltages such as DC transients and peak AC ripples. Note that the result of DC voltage overlapped with peak ripple voltage should not exceed rated voltage.

(3) Ripple Current

One of the key functions of any capacitor is removal of the ripple current i.e. the RMS value of AC flowing through a capacitor. But, a ripple current higher than rated ripple current will drop resultant capacitance, cause undue internal heating and thus reduces life span of the capacitor. In extreme cases, internal high temperature will cause the pressure relief vent to operate while destroying the device. Overall, it is important to note that an electrolytic capacitor must be used within a permissible range of ripple current.

(4) Operating Temperature

Capacitors should be used within a permissible range of operating temperatures. Use of a capacitor at a higher temperature than maximum rated temperature will considerably shorten its life. Usage of capacitors at an ambient room temperature assure their longer life.

(5) Leakage Current

Leakage current flows through a capacitor when DC voltage is applied across it. Leakage current varies with changes in ambient temperature and applied DC voltage level and its time of application. Overvoltage situation, presence of moisture, and thermal stresses, especially occurring during the soldering process can enhance leakage current. Initial leakage current is usually higher and does not decrease until voltage is applied for a certain period of time. It is recommended to keep initial leakage current within specified levels.

(6) Charge and Discharge

OP-CAPs are unsuitable for rapid charging/discharging circuits. Such usage may either cause reduction in overall capacitance or damage due to overheating. **Note that a protection circuit is required when inrush current in an OP-CAP exceeds 10 A.**

(7) Condition of Use

OP-CAP shall not be used / exposed to:

- Fluids including water, saltwater spray, oil, fumes, highly humidity or condensed climates, etc.
- Ambient conditions containing hazardous gases/fumes like hydrogen sulfide, sulfuric acid, nitrous acid, chlorine or bromine gas, ammonia, etc.
- Ozone, ultraviolet rays and radiation.
- Severe vibrations or physical shocks that exceeding the in specifications.

(8) Consideration to Circuit Design

- Please ensure whether application, operating and mounting

conditions satisfy the conditions specified in the catalog before installation of an OP-CAP. Please consult Lelon, if any of the conditions are beyond the conditions specified in the catalog.

- Heat-generating components or heat sinks should not be placed closer to OP-CAPs on the PCB to avoid premature failure. A cooling system is recommended to improve their reliable working.
- Electrical characteristics and performance of OP-CAPs are affected by variation of applied voltage, ripple current, ripple frequency and operating temperature. Therefore, these parameters shall not exceed specified values in the catalog.
- OP-CAPs may be connected in the parallel fashion for increasing total capacitance and/or for achieving higher ripple current capability. But, such design may cause unequal current flow through each of the capacitors due to differences in their impedances.
- When two or more capacitors are connected in series, voltage across each capacitor may differ and fall below the applied voltage. A resistor should be placed across each capacitor so as to match applied voltage with voltage across a capacitor.
- Please consult Lelon while selecting a capacitor for high-frequency switching circuit or a circuit that undergoes rapid charging/ discharging.
- Standard outer sleeve/ coating material of the capacitor is not a perfect electrical insulator therefore is unsuitable for the applications that requires perfect electrical insulation. Please consult Lelon, if your application requires perfect electrical insulation.
- Tilting or twisting capacitor body is not recommended once it is soldered to the PCB.

2. Caution for Assembling Capacitors

(1) Mounting

- OP-CAPs are not recommended to re-use in other circuits once they are mounted and powered in a circuit.
- OP-CAPs may hold static charge between its anode and cathode, which is recommended to be discharge through a 1k Ω resistor before use.
- A long storage of capacitors may result into its insulation deterioration. This can lead to a high leakage current when voltage is applied that may damage the capacitor. Capacitors following a long storage period must undergo voltage treatment/re-forming. Capacitors are charged by applying rated DC voltage through a resistor of 1k Ω in series at least for an hour. It is recommended to increase applied voltage gradually using a voltage regulator unit once capacitors are assembled on the board. The charging should be followed by discharging through a 1k Ω resistor.
- Please check capacitor rated voltage before mounting.
- Please check capacitor polarity before mounting.
- Please don't drop OP-CAPs on the floor/hard object.
- Please don't deform the capacitor during installation.
- Please confirm whether the lead spacing of the capacitors match with its pad spacing/footprint on PCB prior to installation.
- Please avoid excessive mechanical shocks to OP-CAPs during auto-insertion process, inspection or centering operations.

(2) Soldering

- (a) Please confirm that soldering conditions, especially temperature and contact time are within our specifications. Dip or flow soldering temperature should be limited at $260 \pm 5^\circ\text{C}$ for $10 \pm 1\text{sec}$. Please do not dip capacitor body into molten solder. An OP-CAP's life will be negatively affected if these conditions are violated.
- (b) Storage of capacitors in *high humidity* conditions is likely to affect the solderability of lead wires and terminals
- (c) **Reflow soldering should ONLY be used for SMD type conductive polymer capacitors.** Please check the reflow profile prior to using such type of capacitors. The temperature and duration shall not exceed the specified temperature and duration in the catalogue. If required temperature or duration is higher than the value specified, please consult Lelon before use.

- (d) Usually OP-CAPs are not designed to withstand multiple reflow processes. Please consult Lelon if repeated reflowing is unavoidable.
- (e) Incorrect mounting on PCB with improper external strength applied on its lead wires or capacitor body after soldering may damage an OP-CAP's internal structure, cause short circuit, or lead to high leakage current. Do not bend or twist the capacitor body after soldering. Referring to the drawings below only case (i) is recommended.
 - (i) Correct soldering
 - (ii) Hole-to-hole spacing on PCB differs from the lead spacing of lead wires.
 - (iii) Lead wires are bent after soldering.
 - (iv) Capacitor body doesn't stand vertical on PCB after soldering.

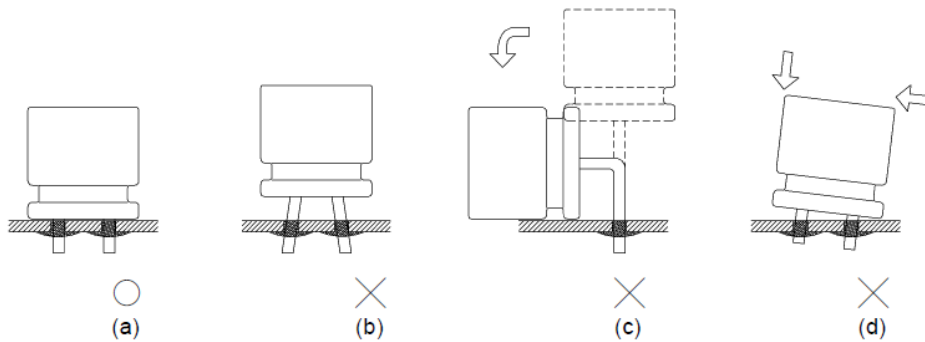

(3) Cleaning PCBs After Soldering

- (a) Following chemicals are not recommended for cleaning: Solvent containing halogen ions, Alkaline solvent, Xylene, Acetone, Terpene, petro-based solvent.
- (b) Recommended cleaning conditions: Fatty-alcohol - Pine Alpha ST-100S, Clean Through-750H and IPA (isopropyl alcohol) are examples of the most acceptable cleaning agents. Temperature of the cleaning agent must not exceed 60°C . Flux content in the cleaning agents should be limited to 2 Wt. %. Overall length of cleaning process (e.g., immersion, ultrasonic or other) shall be within 5 minutes (5 ~ 7mm height within 3 minutes).

3. Maintenance Inspection

Periodic inspection of OP-CAPs is absolutely necessary, especially when they are used with industrial equipment. The following items should be checked:

- (1) Appearance: bloated, vent operated, leaked, etc.
- (2) Electrical characteristic: Capacitance, $\tan \delta$, leakage current, and other specified items listed in specifications.

Lelon recommends replacement of the capacitors if any of the abovementioned items fail to meet the specifications.

4. Storage

- (1) The most suitable conditions for aluminum capacitor storage are $5^\circ\text{C} \sim 35^\circ\text{C}$ with indoor relative humidity less than 75%. High temperature and/or humidity storage is detrimental to the capacitors.
- (2) OP-CAPs shall not be stored in wet or damp atmospheres containing water, brine, fumes or oil.
- (3) Capacitors storage area shall neither be exposed to hazardous gases such as hydrogen sulfide, sulfurous acid, nitrous acid, chlorine, ammonium, etc. nor to acidic/ alkaline solutions.
- (4) OP-CAPs shall not be exposed to ozone, ultraviolet rays or radiation.
- (5) Storage bags shall be opened just before usage. Please restore unused capacitors as soon as possible. Sealed and secured capacitors are likely to provide better solderability in next usage. Shelf-life of OP-CAPs are as follows:

Series name	Before unseal	After unseal
OCV, OCVZ, OCVU, OVH, OVK, OVA, OVE, OVG, OVS, OVF, OVD	Within 1 year after delivery (Unopened condition)	Within 30 days from opening package
OCR, OCRZ, OCRK, OCRU, ORE, ORS, ORA, ORG, ORC, ORF, ORB, ORD	Within 1 year after delivery (Unopened condition)	Within 7 days from opening package

※ It is not applied to the regulation of JEDEC J-STD-020 (Rev. C).

5. Estimation of life time

$$L_r = L_0 \times 10^{\frac{T_0 - T_r}{20}}$$

L_r: Estimated lifetime (hrs)
 L₀: Base lifetime specified at maximum operating temperature with applied the DC voltage
 T₀: Rated maximum operating temperature (°C)
 T_r: Actual ambient temperature (°C)

OCV, OCVZ, OVH, OVK, OCVU, OCR, OCRZ, ORE, OCRK, OCRU	OVA, OVE, OVG, OVS, OVF, OVD, ORS, ORA, ORG, ORC, ORF, ORB, ORD & Aluminum Electrolytic Capacitors
105°C ≧ 2,000 Hours	105°C ≧ 2,000 Hours
95°C ≧ 6,324 Hours	95°C ≧ 4,000 Hours
85°C ≧ 20,000 Hours	85°C ≧ 8,000 Hours
75°C ≧ 63,245 Hours	75°C ≧ 16,000 Hours

Please note that
 (1) Maximum life is 15 years
 (2) Ripple current in application should be less than or equal to ripple current specified in catalogue

6. Disposal

Please consult with a local industrial waste disposal specialist when disposing of aluminum electrolytic capacitors.

7. Environmental Consideration

Lelon already have received ISO 14000 certificate. Cadmium (Cd), Lead (Pb), Mercury (Hg), Hexavalent Chromium (Cr⁶⁺), PBB, PBDE, DEHP, BBP, DBP and DIBP have never been using in capacitor. If you need "Halogen-free" products, please consult with us

8. AEC-Q200 Compliance

Automotive Electronics Counsel (AEC) has established various

electronic component qualification/reliability standards in order to serve automotive electronics industry. AEC-Q200 standard is dedicated for passive components like capacitors, inductors, etc. and is widely adopted domestically as well as internationally. Lelon offers compliant product designs and support services to satisfy customers' product requirements, including the ACE-Q200 required criteria of the reliability tests. Lelon's capacitors are professionally designed to outperform all requirements of ACE-Q200.

For further details, please refer to

IEC 60384-4- Fixed capacitors for use in electronic equipment – Part 4: Sectional specification – Aluminium electrolytic capacitors with solid (MnO₂) and non-solid electrolyte (Established in January 1995, Revised in March 2007), and

EIAJ RCR-2367B- Guideline of notabilia for fixed aluminium electrolytic capacitors for use in electronic equipment [Technical Standardization Committee on Passive Components (Established in March 1995, Revised in March 2002)].