

贴片型铝电解电容器

RZH系列

RZH

特长/用途

- . 4Φ~18Φ 105℃、2,000~5,000小时寿命保证
- . 大额定静电容量并具有极低阻抗之电容器 (RVE系列降低20%-30%)
- . 适用表面黏着之高密度 PCB 设计
- . 符合 RoHS指令

规格表

项 目	性 能									
工作温度范围	-55℃~+105℃									
额定静电容量容许误差值	±20% (120Hz, 20℃)									
额定电压范围	4 ~100V									
标称容量范围	0.1~6800F									
漏 电 流 (20℃)	I=0.01CV或3 (μ A/微安)中的任一个较大值以下(2分钟后) I=漏电流(μ A/微安)、C=额定静电容量(μ F/微法拉)、V=额定直流工作 电压(V/伏特)									
损失角正切值 (120Hz, 20℃)	额定电压	6.3	10	16	25	35	50	63	80	100
	损失角正切 (最大值)	0.30	0.26	0.22	0.16	0.12	0.10	0.08	0.08	0.07
	当额定静电容量大于1.000微法拉时, 每增加1.000微法拉需加0.02。									
温度特性 (120Hz)	阻抗比不可大于下表所列数值									
	额定电压	6.3	10	16	25	35	50	63	80	100
	阻抗比	Z(-25℃)/Z(+20℃)	4	3	2	2	2	2	2	2
耐 久 性	保证寿命时间	ΦD ≤6.3mm: ;2,000小时; ΦD ≥8mm:5,000小时								
	静电容量变化率	≤初始值的±30%								
	损失角正切值	≤初始规格值的300%								
	漏电流	≤初始规格值								
*于105℃环境中供给额定电压2,000/5,000小时后。待制品回复至20℃的环境中进行量测时, 需满足上列要求。										
高温无负荷特性	保证寿命时间	1,000小时								
	静电容量变化率	≤初始值的±30%								
	损失角正切值	≤初始规格值的300%								
	漏电流	≤初始规格值								
*于105℃环境中不供给额定电压1,000小时后。待制品回复至20℃的环境中进行量测时, 需满足上列要求。										
耐焊接热	在250℃的条件下, 电容器在热板上保持30秒, 然后从热板上取下电容器, 让其在室温下恢复, 电容器应满足以下要求									
	容量变化率	±10%初始值内								
	损耗角正切值	≤初始规定值								
纹波电流与频率修正系数	漏电流	≤初始规定值								
	频率 (Hz)	50, 60	120	1k	10ks					
	修正系数	0.60	0.70	0.85	1.0					

寸法图

制品各项寸法

单位: 毫米



ΦD	L	A	B	C	W	P±0.2	图号
4	5.4±0.5	4.3	4.3	5.1	0.5~0.8	1.0	1
5	5.4±0.5	5.3	5.3	5.9	0.5~0.8	1.5	1
6.3	5.4±0.5	6.6	6.6	7.2	0.5~0.8	2.0	1
6.3	7.7±0.5	6.6	6.6	7.2	0.5~0.8	2.0	1
8	6.5±0.5	8.3	8.3	9.0	0.5~0.8	2.3	1
8	10.2±0.5	8.3	8.3	9.0	0.7~1.1	3.1	1
10	7.7±0.5	10.3	10.3	11.0	0.7~1.3	4.7	1
10	10.2±0.5	10.3	10.3	11.0	0.7~1.3	4.7	1
12.5	13.5±0.5	13.0	13.0	13.7	0.7~1.1	4.4	2
12.5	16.5±0.5	13.0	13.0	13.7	0.7~1.1	4.4	2
16	16.5±0.5	17.0	17.0	18.0	1.1~1.4	6.4	2
16	21.5±0.5	17.0	17.0	18.0	1.1~1.4	6.4	2
18	16.5±0.5	19.0	19.0	20.0	1.1~1.4	6.4	2
18	21.5±0.5	19.0	19.0	20.0	1.1~1.4	6.4	2

(*) :4~6.3Φ最大值为0.4

贴片型铝电解电容器

RZH

尺寸: 直径(Φ D)×长度(L), (毫米/mm)
 容许纹波电流: 毫安/均方根值(mA/rms), 100k赫兹 (Hz), 105℃
 阻抗值: 欧姆(Ω)/最大值, 100k赫兹(Hz), 20℃

制品尺寸与容许纹波 电流一览表

额定电压V		63V(1J)			80V(1K)			100V(2A)		
静电容量 (μF/微法拉)		Φ D×L	阻抗值	mA	Φ D×L	阻抗值	mA	Φ D×L	阻抗值	mA
4.7	4R7	5 × 5.7	1.90	70						
10	100	6.3 × 5.7	1.20	130						
22	220	6.3 × 7.7	0.90	150	8 × 10	1.3	130	8 × 10	1.3	130
		6.3 × 6	0.60	136						
33	330	8 × 10	0.50	280	8 × 10	13	130	10 × 10	0.7	200
47	470	8 × 10	0.50	280	10 × 10	0.7	200	10 × 10	0.7	200
100	101	10 × 10	0.25	450	10 × 10	0.7	200	125 × 17	0.32	450
150	151	12.5 × 13.5	0.15	700	12.5 × 13.5	0.32	450	12.5 × 16	0.26	550
220	221	12.5 × 13.5	0.15	700	12.5 × 16	0.26	550	16 × 16 .5	0.15	650
								18 × 21.5		950
330	331	16 × 16.5	0.082	900	16 × 16.5	0.17	650	8 × 16.5	0.15	850
								16 × 21.5		900
470	471	16 × 16.5	0.082	900	16 × 21.5	0.15	900	18 × 21.5	0.15	950
680	681	8 × 16.5	0.080	1.150	18 × 21.5	0.15	950			
		16 × 21 .5	0.080	1.150						
1,000	102	18 × 21.5	0.06	1,250						

产品编码说明

RZH系列 | 16V | 470微法拉 | ±20% | 8*10

RZH | **1C** | **471** | **M** | **0810**

系列名 | 额定电压 | 额定静电容量 | 容许误差值 | 制品尺寸

须定电压(W. V)	4	6.3	10	16	20	25	35	50	63	80	100
电压代码	0G	0J	1A	1C	1D	1E	1V	1H	1J	1K	2A

额定电压(W. V)	160	180	200	250	315	350	400	420	450
电压代码	2C	2S	2D	2E	2F	2V	2G	2P	2W

标称容量	1	2.2	3.3	4.7	6.8	8.2	10	22	33	47	100	150
容量代码	1R0	2R2	3R3	4R7	6R8	8R2	100	220	330	470	101	151
容量允许误差	±5%			±10%			±20%			0~20%		
代码	J			K			M			A		
尺寸	4*5.4		5*5.4		6.3*5.4		6.3*7.7		8*6.5		8*10.2	
代码	0405		0505		0605		0607		0806		0810	
标称容量	220	330	470	680	1000	1500	2200					
容量代码	221	331	471	681	102	152	222					
容量允许误差	-10~30%			-10~20%								
代码	Q			V								
尺寸	10*10.2		8*12		10*12							
代码	1010		0812		1012							

贴片型铝电解电容器

RZH

卷筒

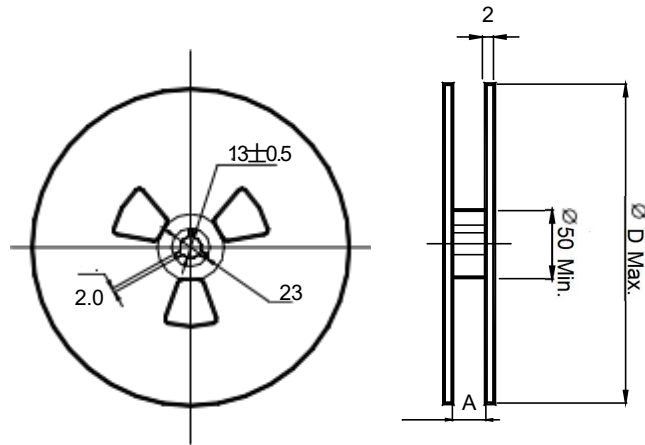

包装数量: Package quantity

规格 Specification	卷装数量 Quantity/Reel	大箱装数量 Quantity/Bag	小箱装数量 Quantity/Bag	A ± 0.3 (MM)	D ± 2 (MM)
Φ4*5.4	2000 pcs	54000pcs	24000pcs	14	382
Φ5*5.4	1000 pcs	27000pcs	12000pcs	14	382
Φ6.3*4.5	1500 pcs	22000pcs	10000pcs	18	382
Φ6.3*5.4	1000 pcs	22000pcs	10000pcs	18	382
Φ6.3*7.7	1000 pcs	16500pcs	7500pcs	18	382
Φ8*10.2	500 pcs	7500pcs	3500pcs	26	382
Φ10*10.2	500 pcs	7500pcs	3500pcs	26	382
Φ12.5*13.5	200 pcs	2400pcs	1000pcs	34	332
Φ16*16.5	125pcs	1125pcs	500pcs	46	332
Φ16*16.5	150 pcs	1350 pcs	600pcs	46	332

贴片型铝电解电容器

无铅回流焊接: Lead-free Reflow Soldering Condition

A. 回流焊条件推荐: Recommended Conditions for Reflow Soldering:

(1) 应采用红外线及热风回流焊接, 不宜采用汽相加热回流焊接;

A thermal condition system such as infrared radiation (IR) or hot blast should be adopted, and vapor heat transfer systems (VPS) are not recommended.

(2) 推荐回流焊只进行一次, 回流焊次数如果需要二次, 必须相隔60分钟以上;

Reflow soldering should be performed one time. If the capacitor has to be reflowed twice, 60 minutes must be layout between each time.

(3) 无铅回流焊, 请符合下述条件:

For lead-free type reflow soldering, please observe proper conditions below:

a) 从150°C至180°C的预热时间 < 120秒以内;

The time of preheating from 150°C to 180°C shall be within maximum 120 seconds;

b) 电容器顶部温度超过217°C的焊接时间不超过tL时间;

The time of soldering temperature at 217°C measured on capacitors' top shall not exceed tL (second);

c) 电容器顶部温度超过230°C的焊接时间不超过td时间;

The time of soldering temperature at 230°C measured on capacitors' top shall not exceed td (second);

d) 电容器顶部尖峰温度不超过Tp°C, 在5°C范围内的实际尖峰温度时间不超过tp时间

The peak temperature on capacitors' top shall not exceed Tp(°C), and the time within 5°C of actual peak temperature shall not exceed tp (second).

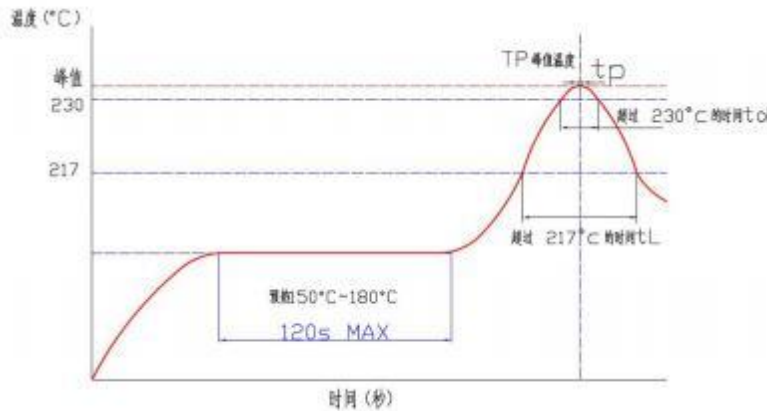

尖峰温度允许范围: Allowable Range of Peak Temperature

Size	Thickness (mm)	Tp (°C)	tL (second)	td (second)	tp (second)
∅4~∅6.3*7.7L	∓2.5	260±0	≤60	≤20	≤5
∅8*6.5L	∓2.5	240±0	≤30	≤10	≤5
∅8/10'13.5L	∓2.5	235±0	≤40	≤10	≤5
∅12.5~∅16	∓3.0	230±0	≤20	--	≤3

表面安装推荐尺寸: Recommended Land Size (Unit: mm)

尺寸Size	X	Y	a
∅4	1.6	2.6	1.0
∅5	1.6	3.0	1.4
∅6.3	1.6	3.5	1.9
∅8	2.5	3.5	3.0
∅10	2.5	4.0	4.0
∅12.5	3.0	5.7	4.0
∅16	3.5	6.5	6.0

