

1. General Description

The 74LVC1G32 is a single 2-input OR gate. Inputs can be driven from either 3.3 V or 5 V devices. This feature allows the use of these devices as translators in mixed 3.3 V and 5 V environments. Schmitt-trigger action at all inputs makes the circuit tolerant of slower input rise and fall times. This device is fully specified for partial power down applications using I_{OFF} . The I_{OFF} circuitry disables the output, preventing the potentially damaging backflow current through the device when it is powered down.

2. Features and Benefits

- Wide supply voltage range from 1.65 V to 5.5 V
- Overvoltage tolerant inputs to 5.5 V
- High noise immunity
- CMOS low power dissipation
- I_{OFF} circuitry provides partial Power-down mode operation
- ± 24 mA output drive ($V_{CC} = 3.0$ V)
- Latch-up performance exceeds 100 mA
- Direct interface with TTL levels
- Complies with JEDEC standard:
 - JESD8-7 (1.65 V to 1.95 V)
 - JESD8-5 (2.3 V to 2.7 V)
 - JESD8-B/JESD36 (2.7 V to 3.6 V)
- ESD protection:
 - HBM ANSI/ESDA/JEDEC JS-001 Class 3B exceeds 8000 V
 - MM JESD22-A115C Class C exceeds 550 V
 - CDM ANSI/ESDA/JEDEC JS-002 Class C3 exceeds 2000 V
- Multiple package options

3. Ordering Information

Table 1. Ordering information

Type number	Topside marking	Package		Quantity
		Name	Description	
74LVC1G32GV	VEYW	SOT23-5L	SOT23 package, 5 pins 2.92 mm × 1.6 mm; 1.25 mm (Max) height	3000
74LVC1G32GW	VEYW	SOT353	SOT353 package, 5 pins 2.1 mm × 1.25 mm; 1.1 mm (Max) height	3000
74LVC1G32GS	VE	DFN1x1-6L	DFN1×1 package, 6 pins 1 mm × 1 mm; 0.42 mm (Max) height	3000
74LVC1G32GM	VEYW	DFN1x1.45-6L	DFN1.45×1 package, 6 pins 1.45 mm × 1 mm; 0.6 mm (Max) height	3000
74LVC1G32GX	VE	DFN0.8x0.8-4L	DFN0.8×0.8 package, 5 pins 0.8 mm × 0.8 mm; 0.4 mm (Max) height	3000

4. Function Diagram

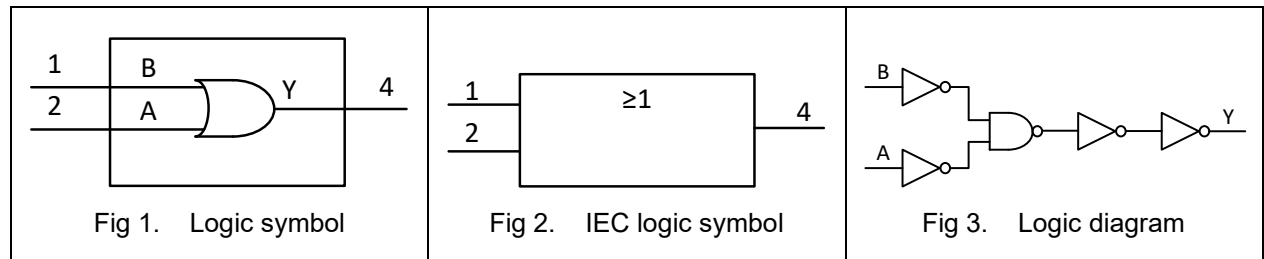

5. Pinning Information

5.1. Pin map

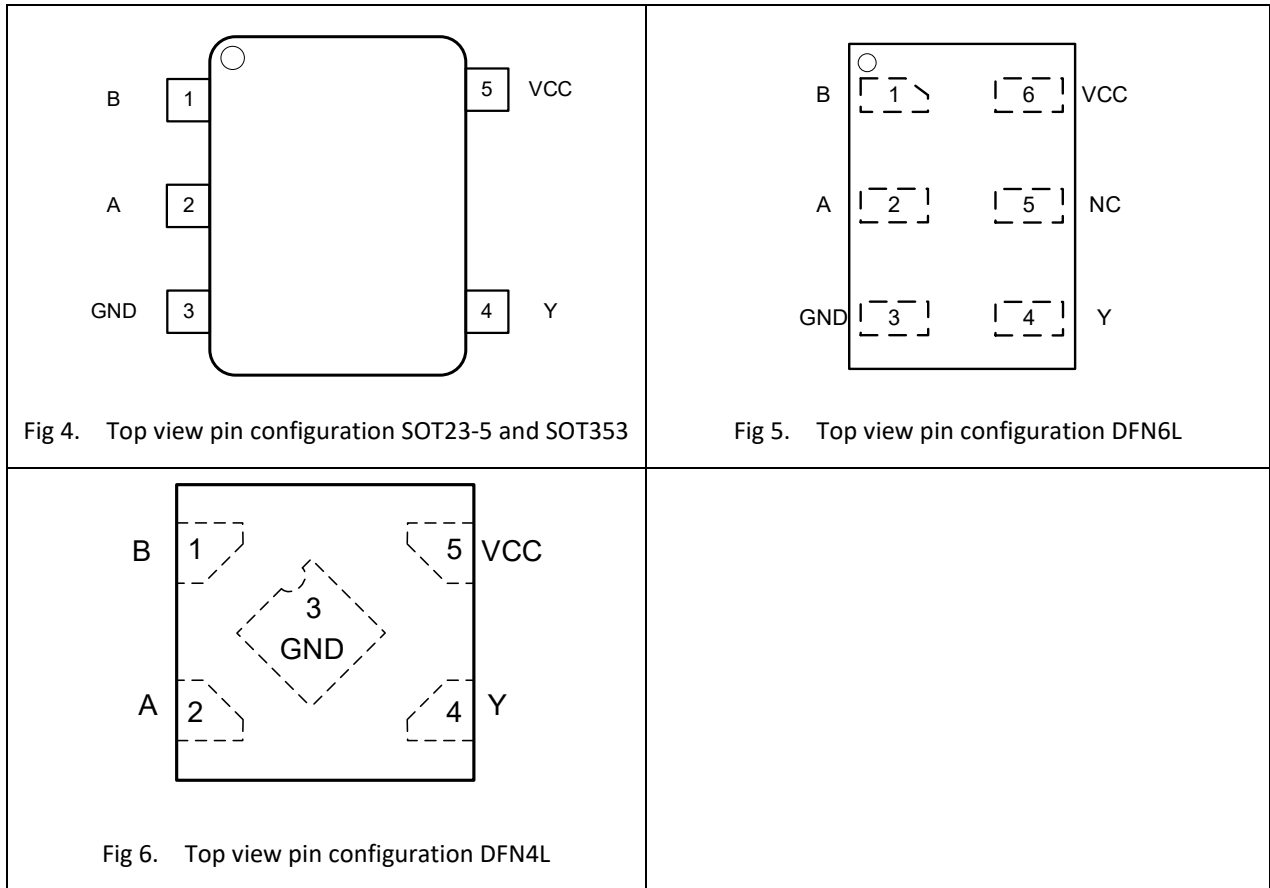

5.2. Pin description

Table 2. Pin description

Symbol	Pin		Description
	SOT23-5, SOT353 and DFN4L	DFN6L	
B	1	1	Data input
A	2	2	Data input
GND	3	3	Ground (0V)
Y	4	4	Data output
NC	-	5	Not connected
VCC	5	6	Supply voltage

6. Functional Description

Table 3. Function table

H = HIGH voltage level; L = LOW voltage level.

Input		Output
A	B	Y
L	L	L
L	H	H
H	L	H
H	H	H

7. Absolute Maximum Ratings

Stresses exceeding the absolute maximum ratings may damage the device. The device may not function or be operable above the recommended operating conditions and stressing the parts to these levels is not recommended. In addition, extended exposure to stresses above the recommended operating conditions may affect device reliability. The absolute maximum ratings are stress ratings only.

Table 4. Absolute Maximum Ratings

In accordance with the Absolute Maximum Rating System (IEC 60134). Voltages are referenced to GND.

Symbol	Parameter	Conditions	Min	Max	Unit
V_{CC}	supply voltage		-0.5	6.5	V
I_{IK}	input clamping current	$V_I < 0\text{ V}$	-50		mA
V_I	input voltage	[1]	-0.5	6.5	V
I_{OK}	output clamping current	$V_O > V_{CC}$ or $V_O < 0\text{ V}$		± 50	mA
V_O	output voltage	Active mode [1]	-0.5	$V_{CC} + 0.5$	V
		Power-down mode; $V_{CC} = 0\text{ V}$ [1]	-0.5	6.5	V
I_O	output current	$V_O = 0\text{ V}$ to V_{CC}		± 50	mA
I_{CC}	supply current			100	mA
I_{GND}	ground current		-100		mA
P_{tot}	total power dissipation	$T_{amb} = -40\text{ °C}$ to $+125\text{ °C}$		250	mW
T_{stg}	storage temperature		-65	150	°C

[1] The input and output voltage ratings may be exceeded if the input and output current ratings are observed.

8. Recommended Operating Conditions

The Recommended Operating Conditions table defines the conditions for actual device operation. Recommended operating conditions are specified to ensure optimal performance to the datasheet specifications. EnergyMath does not recommend exceeding them or designing to Absolute Maximum Ratings.

Table 5. Recommended Operating Conditions

Symbol	Parameter	Conditions	Min	Typ	Max	Unit
V _{CC}	supply voltage		1.65		5.5	V
V _I	input voltage		0		5.5	V
V _O	output voltage	Active mode	0		V _{CC}	V
		Power-down mode; V _{CC} = 0 V	0		5.5	V
T _{amb}	ambient temperature		-40		125	°C
Δt/ΔV	Input transition rise and fall rate	V _{CC} = 1.65 V to 2.7 V			20	ns/V
		V _{CC} = 2.7 V to 5.5 V			10	ns/V

9. Static Characteristics

Table 6. Static characteristics

At recommended operating conditions. Voltages are referenced to GND (ground = 0 V).

Symbol	Parameter	Conditions	-40 °C to +85 °C			-40 °C to +125 °C		Unit
			Min	Typ[1]	Max	Min	Max	
V _{IH}	HIGH-level input voltage	V _{CC} = 1.65 V to 1.95 V	0.65V _{CC}			0.65V _{CC}		V
		V _{CC} = 2.3 V to 2.7 V	1.7			1.7		V
		V _{CC} = 2.7 V to 3.6 V	2.0			2.0		V
		V _{CC} = 4.5 V to 5.5 V	0.7V _{CC}			0.7V _{CC}		V
V _{IL}	LOW-level input voltage	V _{CC} = 1.65 V to 1.95 V			0.35V _{CC}		0.35V _{CC}	V
		V _{CC} = 2.3 V to 2.7 V			0.7		0.7	V
		V _{CC} = 2.7 V to 3.6 V			0.8		0.8	V
		V _{CC} = 4.5 V to 5.5 V			0.3V _{CC}		0.3V _{CC}	V
V _{OH}	HIGH-level output voltage	V _I = V _{IH} or V _{IL}						
		I _O = -100 μA; V _{CC} = 1.65 V to 5.5 V	V _{CC} - 0.1			V _{CC} - 0.1		V
		I _O = -4 mA; V _{CC} = 1.65 V	1.2			0.95		V
		I _O = -8 mA; V _{CC} = 2.3 V	1.9			1.7		V
		I _O = -12 mA; V _{CC} = 2.7 V	2.2			1.9		V
		I _O = -24 mA; V _{CC} = 3.0 V	2.3			2.0		V
		I _O = -32 mA; V _{CC} = 4.5 V	3.8			3.4		V
V _{OL}	LOW-level output voltage	V _I = V _{IH} or V _{IL}						
		I _O = 100 μA; V _{CC} = 1.65 V to 5.5 V			0.10		0.10	V
		I _O = 4 mA; V _{CC} = 1.65 V			0.45		0.70	V
		I _O = 8 mA; V _{CC} = 2.3 V			0.30		0.45	V
		I _O = 12 mA; V _{CC} = 2.7 V			0.40		0.60	V
		I _O = 24 mA; V _{CC} = 3.0 V			0.55		0.80	V
		I _O = 32 mA; V _{CC} = 4.5 V			0.55		0.80	V
I _I	Input leakage current	V _I = 5.5 V or GND ; V _{CC} = 0 V to 5.5 V		±0.1	±1		±1	μA
I _{OFF}	power-off leakage current	V _{CC} = 0V ; V _I or V _O = 5.5 V		±0.1	±2		±2	μA

I_{CC}	supply current	$V_I = 5.5V$ or GND ; $I_O = 0A$; $V_{CC} = 1.65V$ to $5.5V$		0.1	4		4	μA
ΔI_{CC}	additional supply current	per pin ; $V_{CC} = 2.3V$ to $5.5V$; $V_I = V_{CC} - 0.6V$; $I_O = 0A$		5	500		500	μA
C_i	input capacitance	$V_{CC} = 3.3V$; $V_I = GND$ to V_{CC}		5				μF

[1] All typical values are measured at $V_{CC} = 3.3V$ and $T_{amb} = 25^\circ C$.

10. Dynamic Characteristics

Table 7. Dynamic characteristics

Voltages are referenced to GND (ground = 0 V); for test circuit see Fig. 8.

Symbol	Parameter	Conditions	-40 °C to +85 °C			-40 °C to +125 °C		Unit
			Min	Typ[1]	Max	Min	Max	
t_{pd}	propagation delay	A to Y; see Fig. 7 [2]						
		$V_{CC} = 1.65 V$ to $1.95 V$	3.4	9.4	15.9	3.4	16.3	ns
		$V_{CC} = 2.3 V$ to $2.7 V$	2.4	5.0	8.6	2.4	9.1	ns
		$V_{CC} = 3.0 V$ to $3.6 V$	1.8	3.9	6.0	1.8	6.3	ns
		$V_{CC} = 4.5 V$ to $5.5 V$	1.4	2.6	3.6	1.4	3.8	ns
C_{PD}	power dissipation capacitance	$V_I = GND$ to V_{CC} ; $V_{CC} = 3.3V$ [3]		24				μF

[1] Typical values are measured at $T_{amb} = 25^\circ C$ and $V_{CC} = 1.8 V, 2.5 V, 3.3 V$ and $5.0 V$ respectively.

[2] t_{pd} is the same as t_{PLH} and t_{PHL} .

[3] C_{PD} is used to determine the dynamic power dissipation (P_D in μW).

$P_D = C_{PD} \times V_{CC}^2 \times f_i \times N + \sum(C_L \times V_{CC}^2 \times f_o)$ where:

f_i = input frequency in MHz;

f_o = output frequency in MHz;

C_L = output load capacitance in pF;

V_{CC} = supply voltage in V;

N = number of inputs switching;

$\sum(C_L \times V_{CC}^2 \times f_o)$ = sum of outputs.

10.1. Waveforms and test circuit

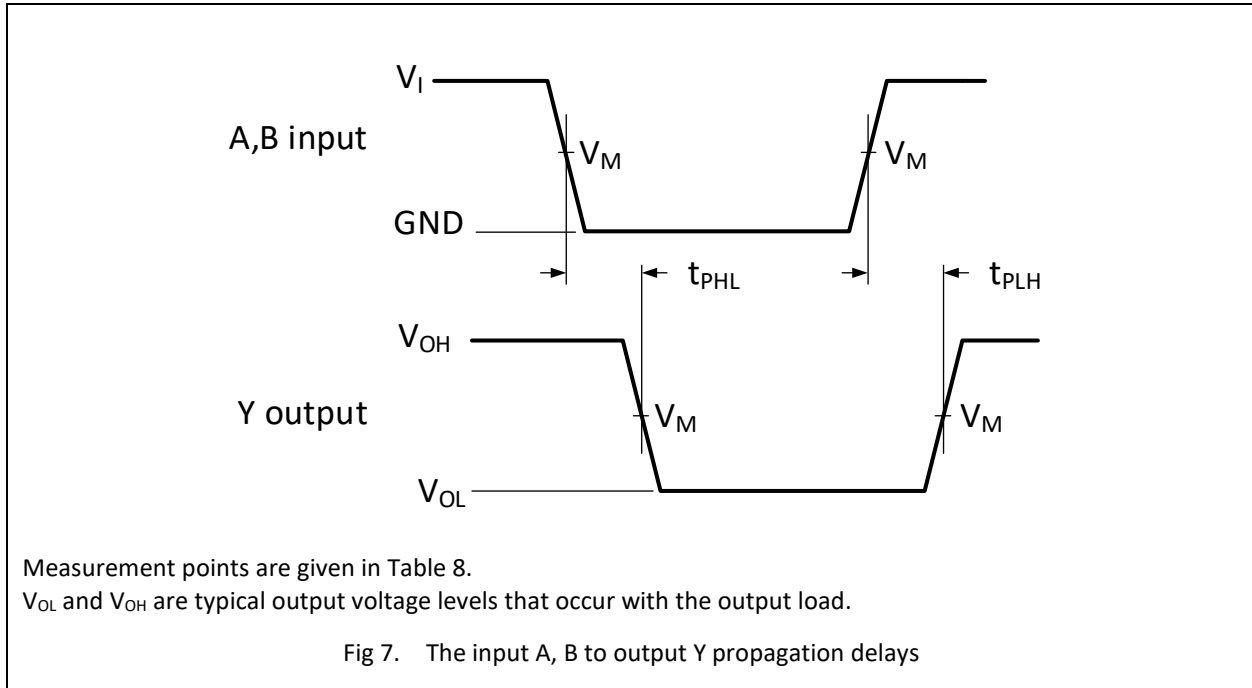
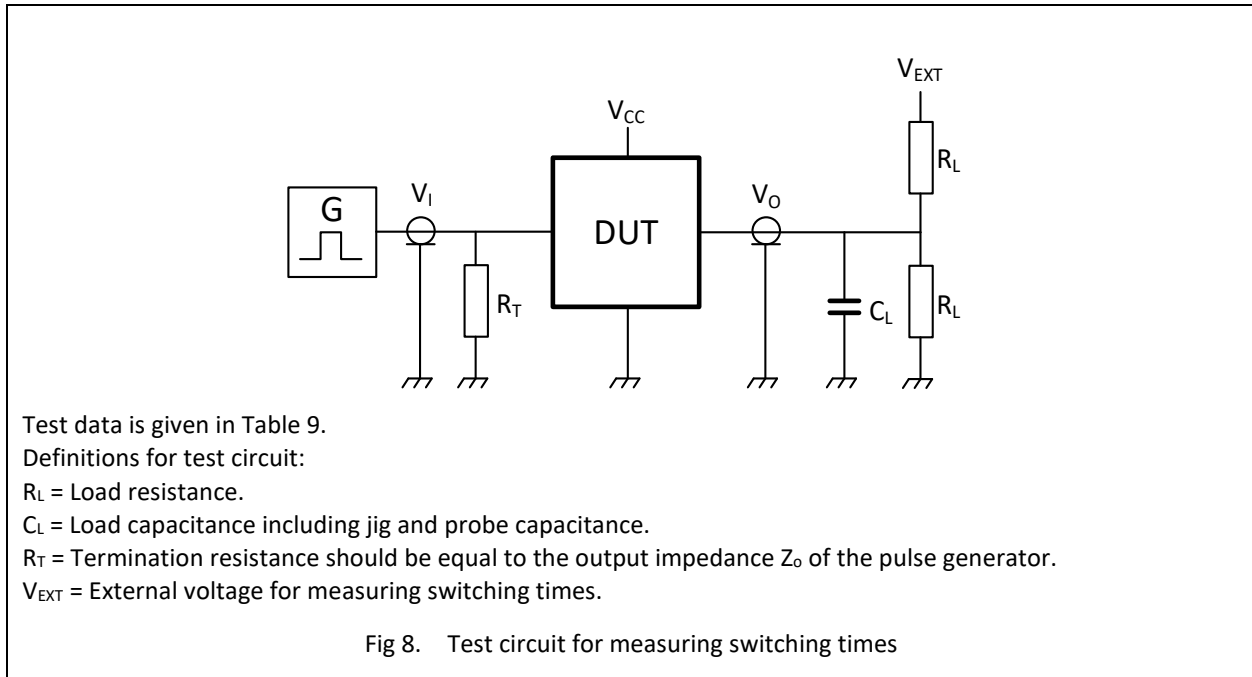

Table 8. Measurement points

Supply voltage	Input	Output
V_{CC}	V_M	V_M
1.65 V to 1.95 V	$0.5V_{CC}$	$0.5V_{CC}$
2.3 V to 2.7 V	$0.5V_{CC}$	$0.5V_{CC}$
3.0 V to 3.6 V	1.5 V	1.5 V
4.5 V to 5.5 V	$0.5V_{CC}$	$0.5V_{CC}$

Table 9. Test data

Supply voltage	Input		Load		V_{EXT}
V_{CC}	V_I	$t_r = t_f$	C_L	R_L	t_{PLH}, t_{PHL}
1.65 V to 1.95 V	V_{CC}	≤ 2.0 ns	30 pF	1 k Ω	open
2.3 V to 2.7 V	V_{CC}	≤ 2.0 ns	30 pF	500 Ω	open
3.0 V to 3.6 V	3 V	≤ 2.5 ns	50 pF	500 Ω	open
4.5 V to 5.5 V	V_{CC}	≤ 2.5 ns	50 pF	500 Ω	open

11. Package Outline

SOT23-5L

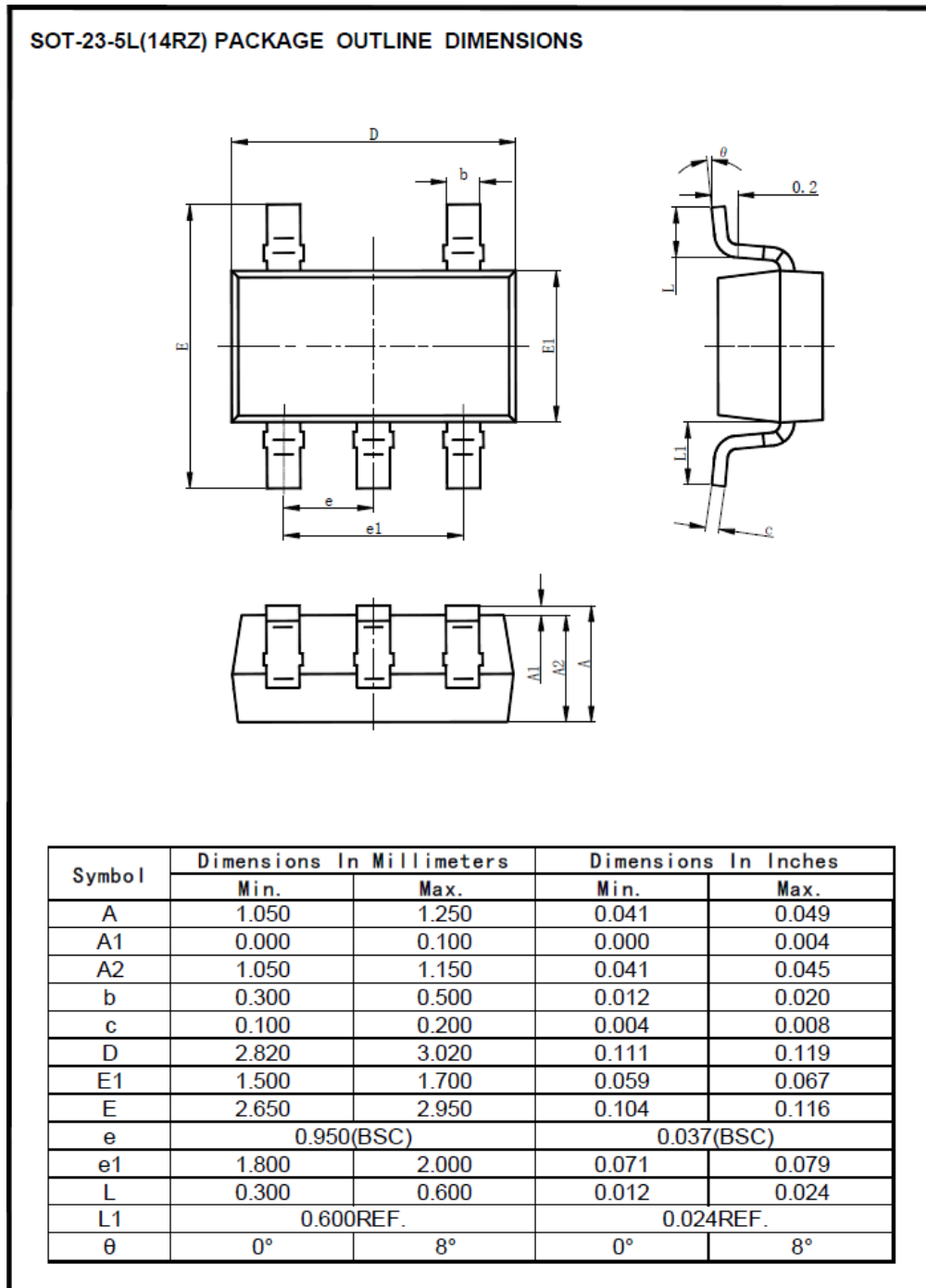

SOT353

SOT-353 (16R) PACKAGE OUTLINE DIMENSIONS

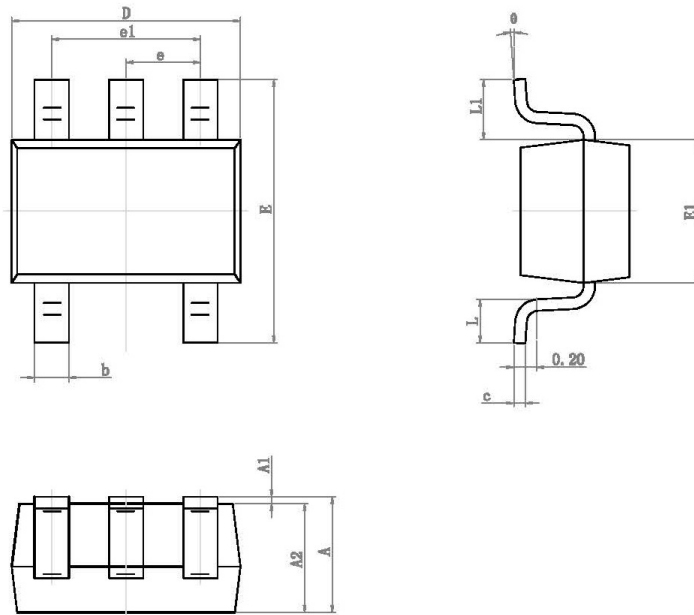

Symbol	Dimensions In Millimeters		Dimensions In Inches	
	Min.	Max.	Min.	Max.
A	0.900	1.100	0.035	0.043
A1	0.000	0.100	0.000	0.004
A2	0.900	1.000	0.035	0.039
b	0.150	0.350	0.006	0.014
c	0.110	0.175	0.004	0.007
D	2.000	2.200	0.079	0.087
E	2.150	2.450	0.085	0.096
E1	1.150	1.350	0.045	0.053
e	0.650 TYP.		0.026 TYP.	
e1	1.200	1.400	0.047	0.055
L	0.260	0.460	0.010	0.018
L1	0.525 REF.		0.021 REF.	
θ	0°	8°	0°	8°

DFN1x1-6L

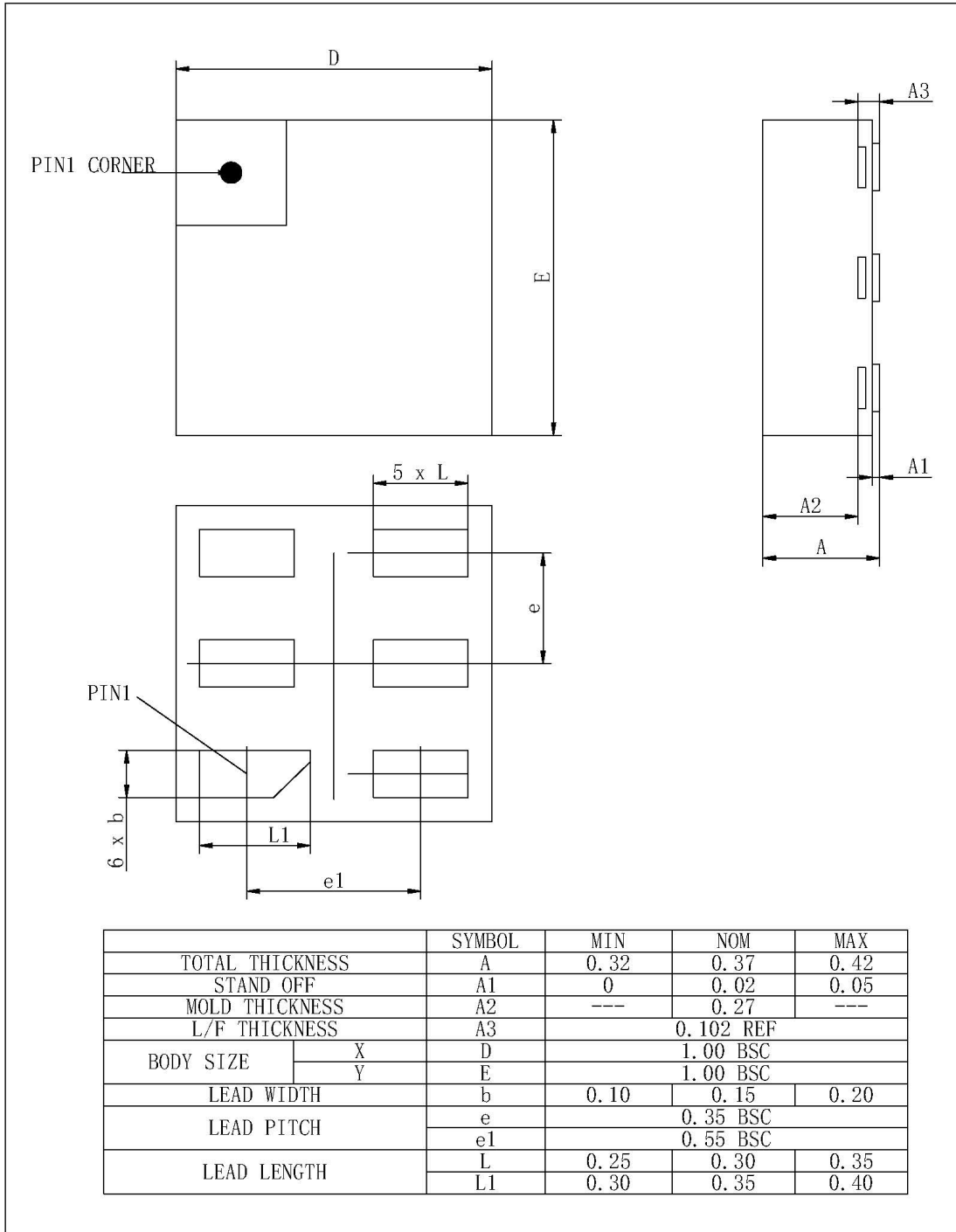

DFN1x1.45-6L

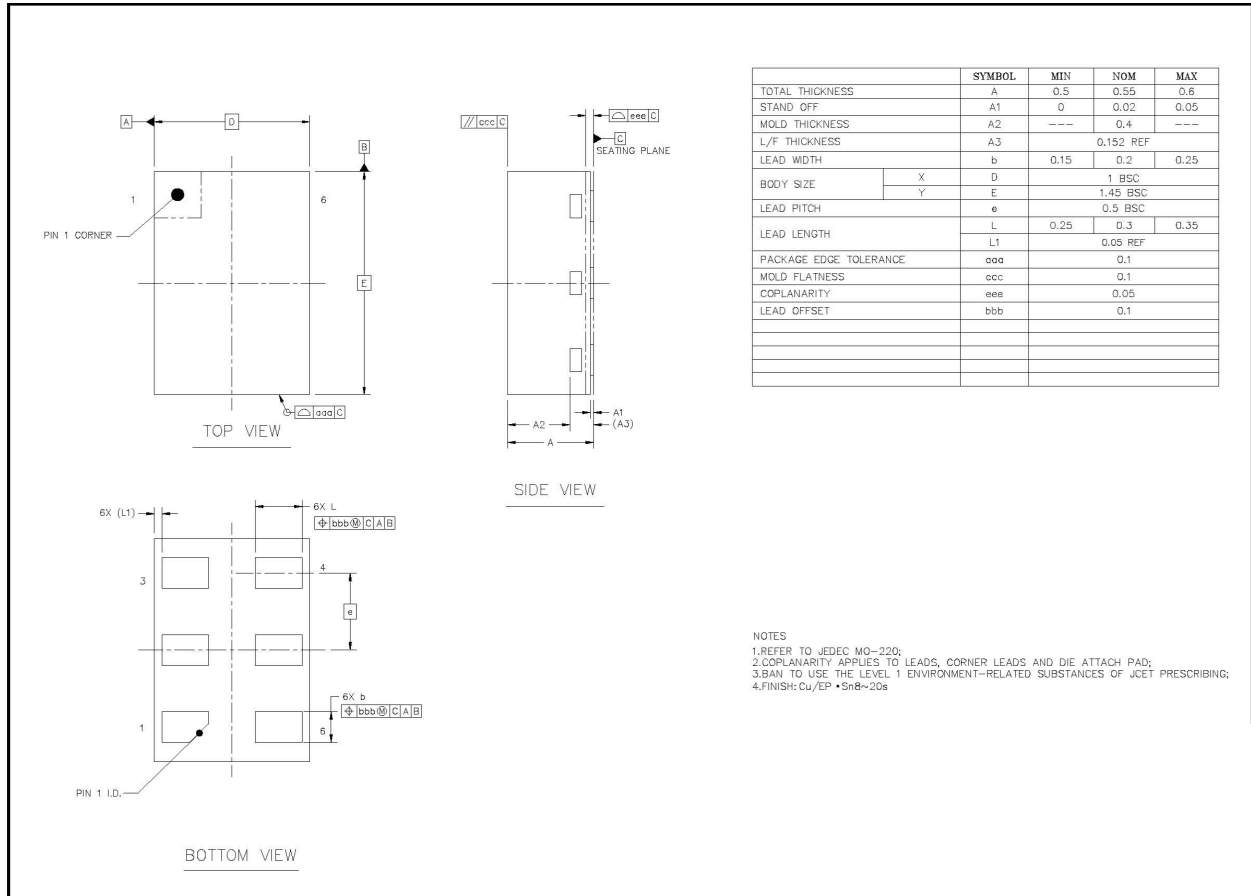

DFN0.8x0.8-4L

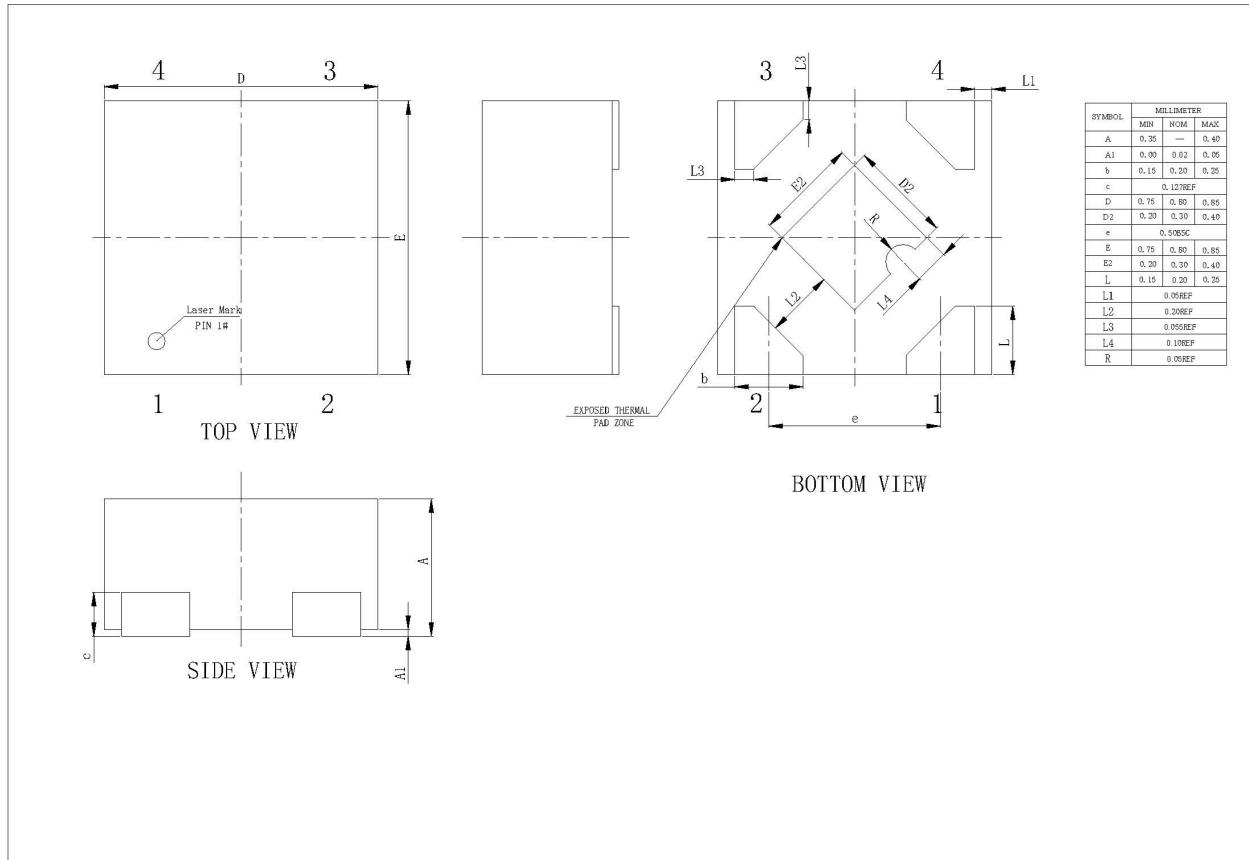

12. Abbreviations

Table 10. Abbreviations

Acronym	Description
CMOS	Complementary Metal-Oxide Semiconductor
DUT	Device Under Test
ESD	ElectroStatic Discharge
HBM	Human Body Model
MM	Machine Model
TTL	Transistor-Transistor Logic

13. Revision History

Table 11. Revision history

Document ID	Release Date	Data sheet status	Change notice	Supersedes
74LVC1G32 Rev1.0	Aug 08, 2024	Product datasheet		