

芯伯乐®
X I N B O L E

Product Specification

XBLW INA199AxDCKR

Bi-directional, Zero-Drift Current Sense Amplifiers

WEB | www.xinboleic.com



Descriptions

The INA199 series of bidirectional zero-drift current sense amplifier can sense drop across shunts at common-mode voltages from -0.3V to 26V, independent of the supply voltage. Unidirectional operation allows the INA199 series to measure currents through resistive shunt in one direction, while bidirectional operation allows the device to measure currents through a resistive shunt in two directions. The low offset of the zero-drift architecture enables current sensing with maximum drops across the shunt as low as 10mV full-scale. The INA199 series operates from a single +2.5V to +18V power supply, drawing a maximum of 100µA of supply current. The device is specified from -40°C to +105°C, and offered in SC70-6 (SOT-363) packages.

Features

- Wide common-mode range: -0.3V to 26V
- Maximum 180µV Offset voltage (INA199A2/A3) Enable Shunt Drops of 10mV Full-scale
- Accuracy
 - Maximum ±0.5% Gain Error
 - Maximum 0.5µV/°C Offset Drift
 - Maximum 10ppm/°C Gain Drift
- Choice of Gains:
 - INA199A1: 50V/V
 - INA199A2: 100V/V
 - INA199A3: 200V/V
- Quiescent Current: Maximum 100µA
- Package: SC70-6 (SOT-363)

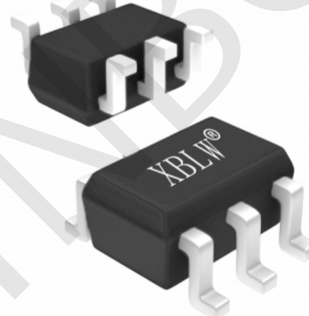

SC70-6

Applications

- Power Management
- Battery Chargers
- Electrical Cigarette
- Smart Phones and Tablets
- Notebook Computers
- Telecom Equipments
- Welding Equipments

Ordering Information

Product Model	Package Type	Marking*	Packing	Packing Qty
XBLW INA199A1DCKR	SC70-6	OBG/9X1	Tape	3000Pcs/Reel
XBLW INA199A2DCKR	SC70-6	OBH/9X2	Tape	3000Pcs/Reel
XBLW INA199A3DCKR	SC70-6	OBI/9X3	Tape	3000Pcs/Reel

*: "X" represents a variable, updated with the silk screen batch.

Block Diagram

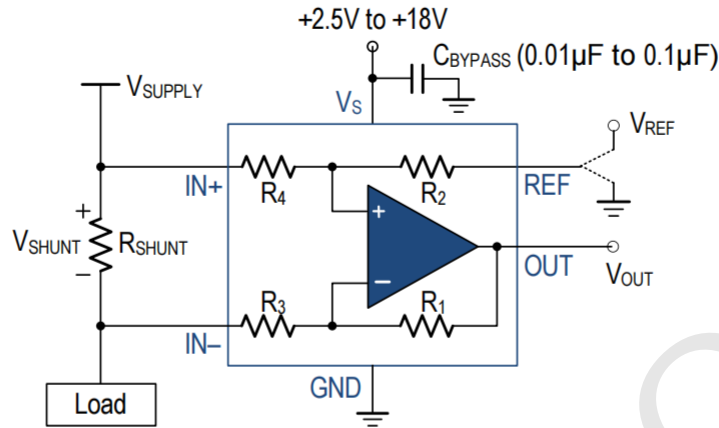

High-side Sensing Application

Pin Configurations

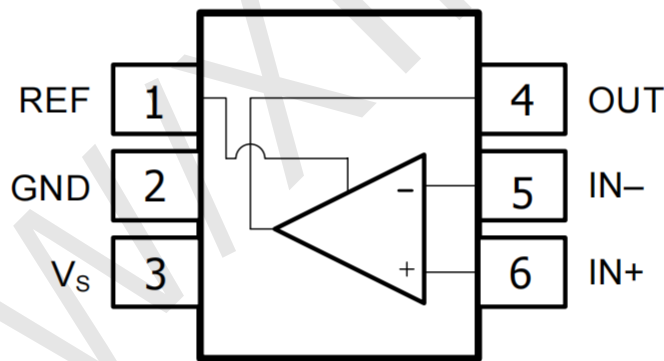

SC70-6(SOT-363)

Pin Description

Symbol	Description
IN -	Inverting input of the amplifier.
IN+	Non-inverting input of the amplifier.
OUT	Amplifier output. The voltage range extends to within millivolt of each supply rail.
REF	Reference voltage
V _s	Positive power supply. Typically, the voltage is from +2.5V to +18V. A bypass capacitor of 0.1μF as close to the part as possible should be used between power supply pin and ground pin.
GND	Negative power supply.

Absolute Maximum Ratings

In accordance with the Absolute Maximum Rating System (IEC 60134).

Parameter	Absolute Maximum Rating
Supply Voltage, VS to GND	+20V
Analog Input (IN+, IN-), Differential (VIN+ – VIN-)	-26V to +26V
Analog Input (IN+, IN-), Common-Mode	(GND – 0.3V) to +26V
REF Input	(GND – 0.3V) to (V+ + 0.3V)
Output	(GND – 0.3V) to (V+ + 0.3V)
Input Current Into All Pins	5mA
Storage Temperature Range	-65°C to +150°C
Junction Temperature	150°C
Lead Temperature Range (Soldering 10 sec)	260°C

ESD Rating

Parameter	Item	Value	Unit
Electrostatic Discharge Voltage	Human body model (HBM), per MIL-STD-883J / Method 3015.9 ⁽¹⁾	±4000	V
	Charged device model (CDM), per ESDA/JEDEC JS-002-2014 ⁽²⁾	±2000	
	Machine model (MM), per JESD22-A115C	±400	

(1) JEDEC document JEP155 states that 500-V HBM allows safe manufacturing with a standard ESD control process.

(2) JEDEC document JEP157 states that 250-V CDM allows safe manufacturing with a standard ESD control process.

Electrical Characteristics

T_A = +25°C, V_S = +5.0V, V_{IN+} = 12V, V_{SENSE} = V_{IN+} – V_{IN-}, and V_{REF} = V_S/2, unless otherwise noted. Boldface limits apply over the specified temperature range, T_A = -40 to +105 °C.

Symbol	Parameter	Conditions	Min.	Typ.	Max.	Unit
INPUT CHARACTERISTICS						
V _{OS}	Referred-to-input offset voltage	V _{SENSE} = 0mV, INA199A1	-250	+50	+300	μV
		V _{SENSE} = 0mV, INA199A2 / INA199A3		±50	±180	
V _{OS} TC	Offset voltage drift	over Temperature		0.1	0.5	μV/°C
I _B	Input bias current	V _{SENSE} = 0mV		25		μA
I _{OS}	Input offset current	V _{SENSE} = 0mV		0.02		μA
V _{CM}	Common-mode input voltage range		-0.3		26	V
CMRR	Common-mode rejection ratio	V _{IN+} = 0 V to +24V, V _{SENSE} = 0mV, INA199A1	91	105		dB
		V _{IN+} = 0 V to +26V, V _{SENSE} = 0mV, INA199A2 / INA199A3	96	110		

OUTPUT CHARACTERISTICS						
G	Gain	INA199A1		50		V/V
		INA199A2		100		
		INA199A3		200		
E _G	Gain error	V _{SENSE} = -5mV to 5mV		±0.03	±0.5	%
E _G TC	Gain error drift	Over Temperature		3	10	ppm/°C
	Nonlinearity Error	V _{SENSE} = -5mV to 5mV		±0.01		%
C _L	Maximum Capacitive Load	No sustained oscillation		1		nF
V _{OH}	Swing to V _S rail	R _L = 10kΩ to GND	V _S -200	V _S -50		mV
V _{OL}	Swing to GND			V _{GND} +5	V _{GND} +50	
DYNAMIC PERFORMANCE						
BW	Bandwidth	INA199A1, C _{LOAD} = 10pF		80		kHz
		INA199A2, C _{LOAD} = 10pF		30		
		INA199A3, C _{LOAD} = 10pF		14		
SR	Slew rate			0.65		V/μs
NOISE PERFORMANCE						
e _n	Voltage noise density	Referred-to-input		25		nV/√ Hz
POWER SUPPLY						
V _S	Operating supply voltage		+2.5		+18	V
PSR	Input vs power supply	V _S = +2.5V to +18V, V _{IN+} = +18V, V _{SENSE} = 0mV		±0.1		μV/V
I _Q	Quiescent current	V _{SENSE} = 0mV		70	100	μA
	over Temperature				115	
THERMAL CHARACTERISTICS						
T _A	Operating temperature		-40		+105	°C
θ _{JA}	Package Thermal Resistance	SC70-6L		250		°C/W

Typical Performance Characteristics

At $T_A = +25^\circ\text{C}$, $V_S = +5.0\text{V}$, $V_{IN+} = 12\text{V}$, and $V_{REF} = V_S/2$, unless otherwise noted.

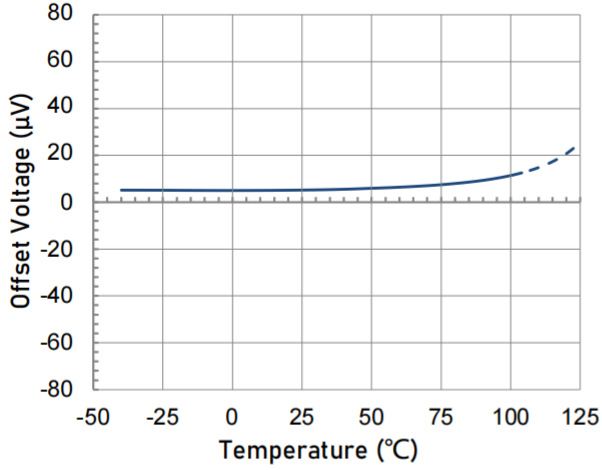

Offset Voltage vs. Temperature

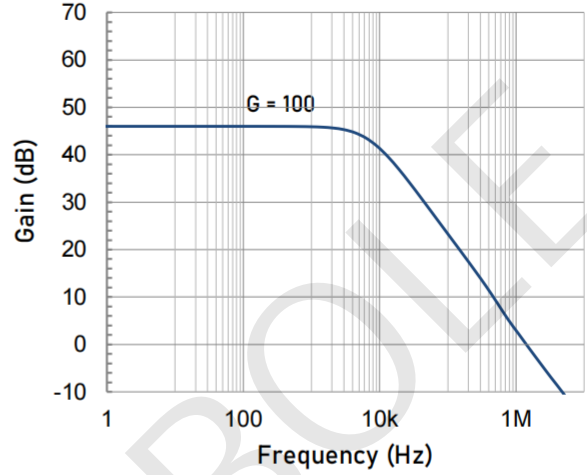

Gain vs. Frequency

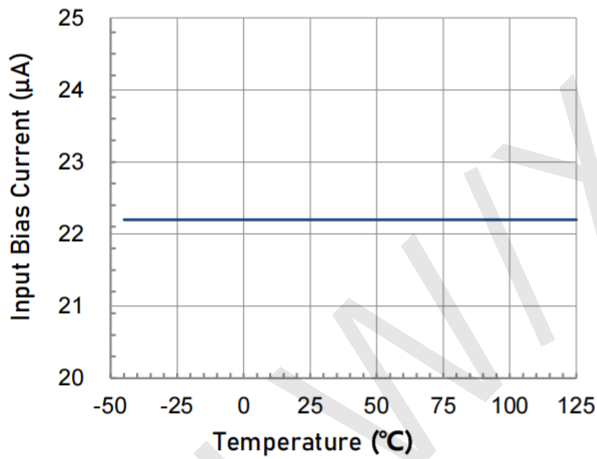

Input Bias Current vs. Temperature

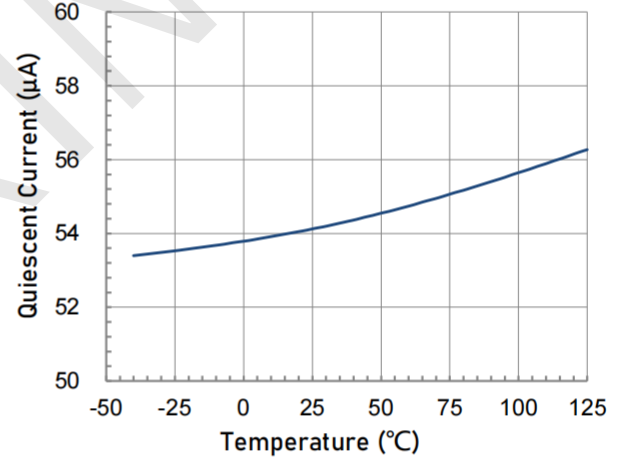

Quiescent Current vs. Temperature

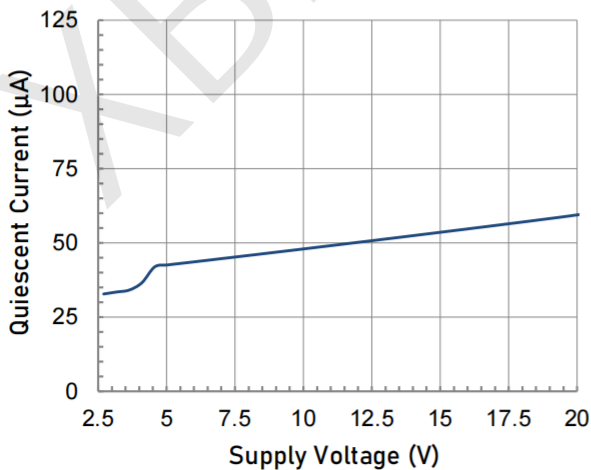

Quiescent Current vs. Supply Voltage

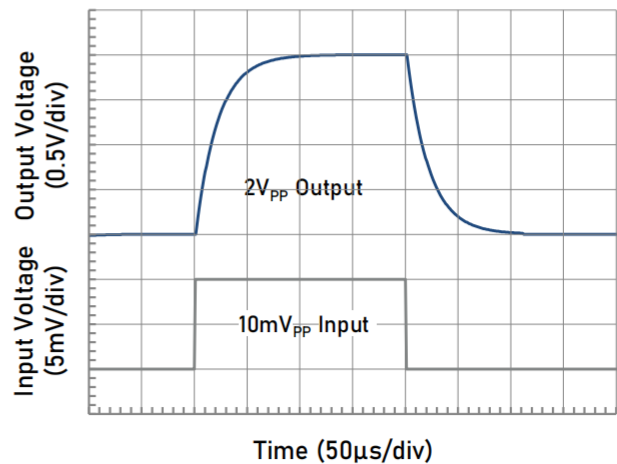

Step Response (10mV_{pp} Input Step)

Typical Performance Characteristics (continued)

At $T_A = +25^\circ\text{C}$, $V_S = +5.0\text{V}$, $V_{IN+} = 12\text{V}$, and $V_{REF} = V_S/2$, unless otherwise noted.

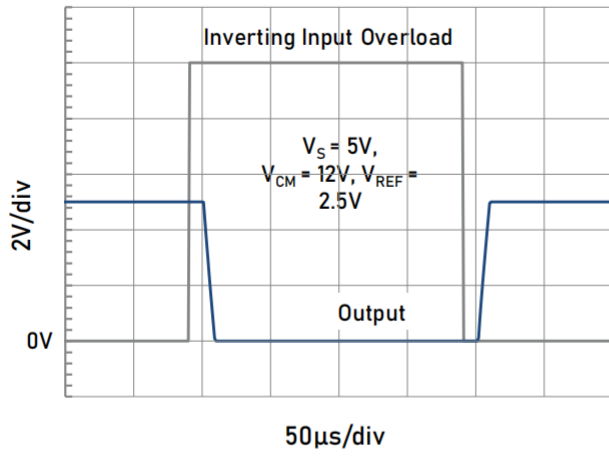

Inverting Differential Input Overload

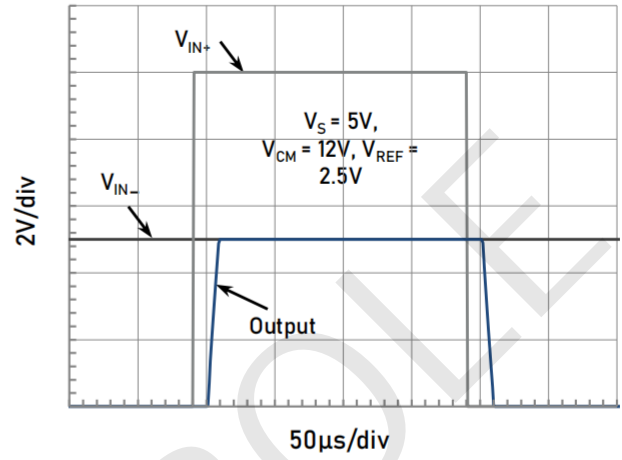

Noninverting Differential Input Overload

Application Notes

BASIC CONNECTIONS

Figure 1 shows the basic connections for the INA199. The input pins, IN+ and IN-, should be connected as closely as possible to the shunt resistor to minimize any resistance in series with the shunt resistance. Power-supply bypass capacitors are required for stability. Applications with noisy or high-impedance power supplies may require additional decoupling capacitors to reject power-supply noise. Connect bypass capacitors close to the device pins.

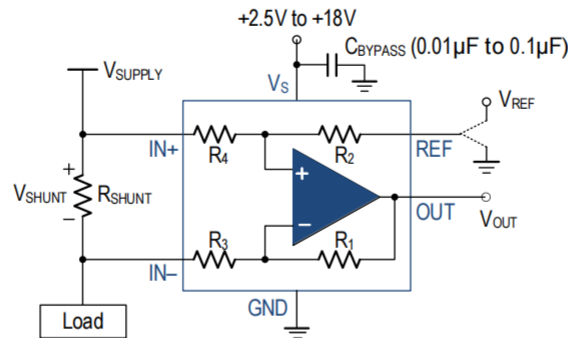

High-side Sensing Application
Figure 1. Typical Application

POWER SUPPLY

The input circuitry of the INA199 can accurately measure beyond its power-supply voltage, V_S . For example, the V_S power supply can be 5V, whereas the load power-supply voltage can be as high as +18V. However, the output voltage range of the OUT terminal is limited by the voltages on the power-supply pin. Note also that the INA199 can withstand the full -0.3V to +26V range in the input pins, regardless of whether the device has power applied or not.

SELECTING R_S

The zero-drift offset performance of the INA199 offers several benefits. Most often, the primary advantage of the low offset characteristic enables lower full-scale drops across the shunt. For example, non-zero-drift current sense amplifiers typically require a full-scale range of 100mV.

The INA199 of current sense amplifier gives equivalent accuracy at a full-scale range on the order of 10mV. This accuracy reduces shunt dissipation by an order of magnitude with many additional benefits.

Alternatively, there are applications that must measure current over a wide dynamic range that can take advantage of the low offset on the low end of the measurement. Most often, these applications can use the lower gain of 100 to accommodate larger shunt drops on the upper end of the scale.

UNIDIRECTIONAL OPERATION

Unidirectional operation allows the INA199 to measure currents through a resistive shunt in one direction. The most frequent case of unidirectional operation sets the output at ground by connecting the REF pin to ground. In unidirectional applications where the highest possible accuracy is desirable at very low inputs, bias the REF pin to a convenient value above 50mV to get the device output swing into the linear range for zero inputs.

A less frequent case of unipolar output biasing is to bias the output by connecting the REF pin to the supply; in this case, the quiescent output for zero input is at quiescent supply. This configuration would only respond to negative currents (inverted voltage polarity at the device input).

BIDIRECTIONAL OPERATION

Bidirectional operation allows the INA199 to measure currents through a resistive shunt in two directions. In this case, the output can be set anywhere within the limits of what the reference inputs allow (that is, between 0V to V_+). Typically, it is set at half-scale for equal range in both directions. In some cases, however, it is set at a voltage other than half-scale when the bidirectional current is nonsymmetrical.

The quiescent output voltage is set by applying voltage to the reference input. Under zero differential input conditions the output assumes the same voltage that is applied to the reference input.

INPUT FILTERING

An obvious and straightforward filtering location is at the device output. However, this location negates the advantage of the low output impedance of the internal buffer. The only other filtering option is at the device input pins. This location, though, does require consideration of the $\pm 30\%$ tolerance of the internal resistances. Figure 2 shows a filter placed at the inputs pins.

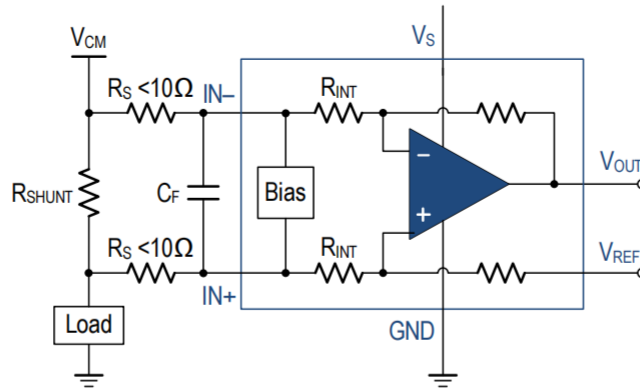

Figure 2. Filter at Input Pins

The addition of external series resistance, however, creates an additional error in the measurement so the value of these series resistors should be kept to 10Ω or less if possible to reduce impact to accuracy. The internal bias network shown in Figure 2 present at the input pins creates a mismatch in input bias currents when a differential voltage is applied between the input pins. If additional external series filter resistors are added to the circuit, the mismatch in bias currents results in a mismatch of voltage drops across the filter resistors. This mismatch creates a differential error voltage that subtracts from the voltage developed at the shunt resistor. This error results in a voltage at the device input pins that is different than the voltage developed across the shunt resistor. Without the additional series resistance, the mismatch in input bias currents has little effect on device operation. The amount of error these external filter resistor add to the measurement can be calculated using Equation 2 where the gain error factor is calculated using Equation 1.

The amount of variance in the differential voltage present at the device input relative to the voltage developed at theshunt resistor is based both on the external series resistance value as well as the internal input resistors, R_{INT} as shown in Figure 2. The reduction of the shunt voltage reaching the device input pins appears as a gain error when comparing the output voltage relative to the voltage across the shunt resistor. A factor can be calculated to determine the amount of gain error that is introduced by the addition of external series resistance. The equation used to calculate the expected deviation from the shunt voltage to what is seen at the device input pins is given in Equation 1:

$$\text{Gain Error Factor} = 1250 \times R_S + 1250 \times R_{INT} + R_S \times R_{INT}$$

where:

R_{INT} is the internal input resistor (R3 and R4, 10kΩ), and R_S is the external series resistance.

The gain error that can be expected from the addition of the external series resistors can then be calculated based on Equation 2:

$$\text{Gain Error (\%)} = 100 - (100 \times \text{Gain Error Factor})$$

For INA199 , a series resistance of 10Ω results in a gain err or factor of 0.991. The corresponding gain error is then calculated using Equation 2, resulting in a gain erro r of approximately 0.89% solely because of the external 10Ω series resistors.

Package Information

SC70-6 (SOT-363)

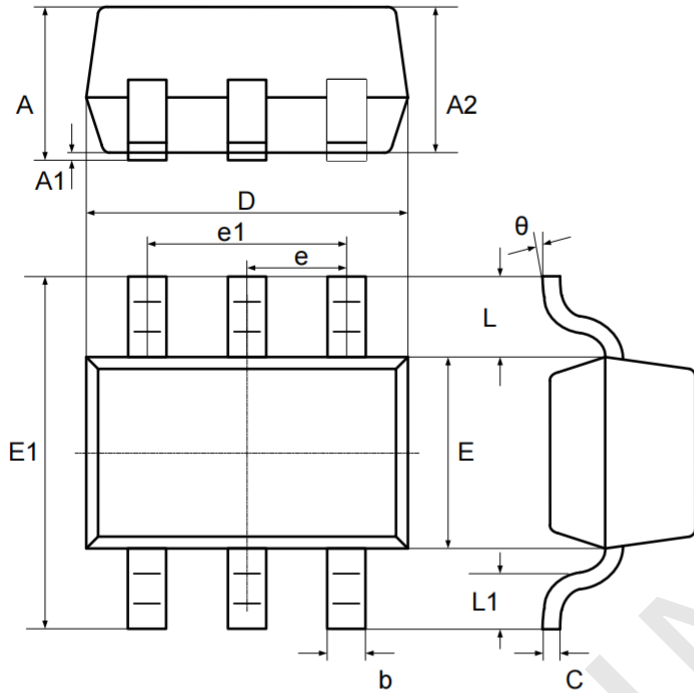

Symbol	Dimensions In Millimeters		Dimensions In Inches	
	Min	Max	Min	Max
A	0.80	1.10	0.031	0.043
A1	0.00	0.10	0.000	0.004
A2	0.80	1.00	0.031	0.039
b	0.15	0.30	0.006	0.012
C	0.10	0.25	0.004	0.010
D	1.85	2.20	0.073	0.087
E	1.15	1.35	0.045	0.053
E1	1.80	2.40	0.071	0.094
e	0.65 typ.		0.026 typ.	
e1	1.20	1.40	0.047	0.055
L	0.42 ref.		0.017 ref.	
L1	0.10	0.45	0.004	0.018
θ	0°	8°	0°	8°

RECOMMENDED SOLDERING FOOTPRINT, SC70-6 (SOT-363)

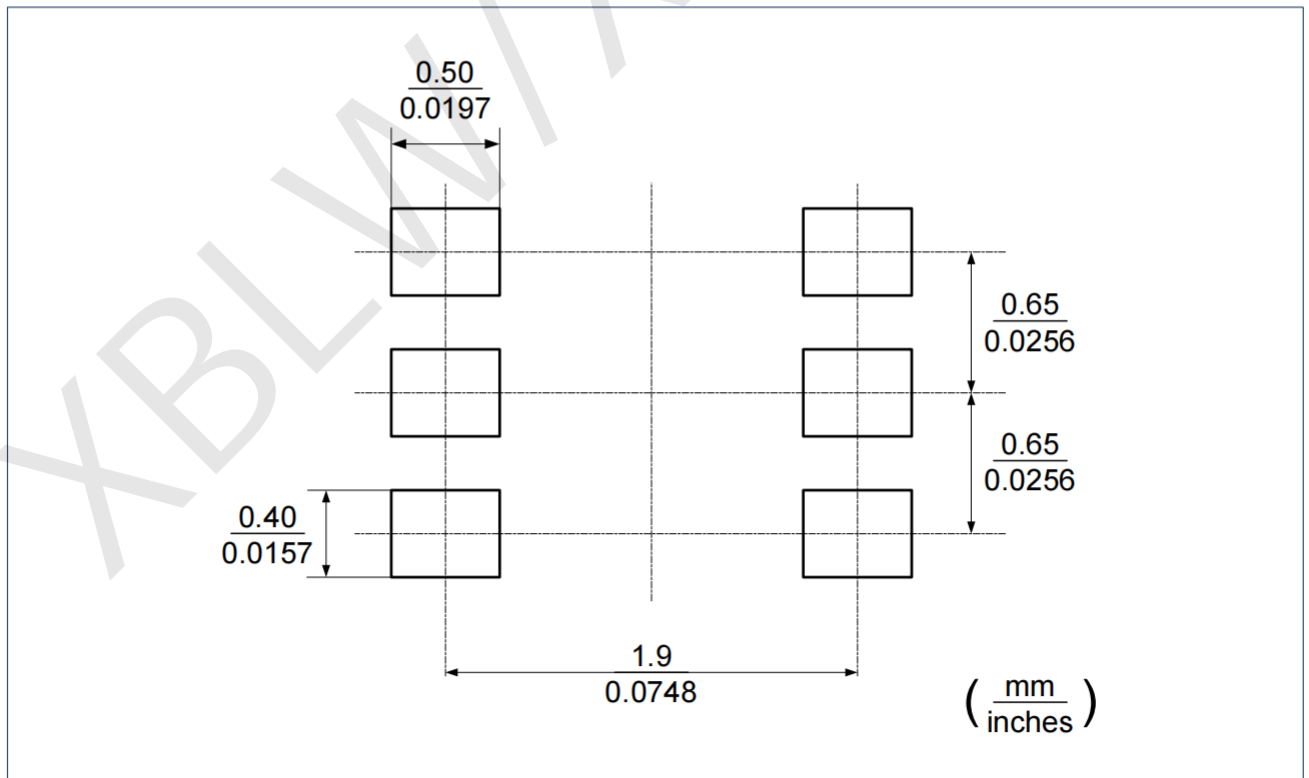

Statement:

- XBLW reserves the right to modify the product manual without prior notice! Before placing an order, customers need to confirm whether the obtained information is the latest version and verify the completeness of the relevant information.
- Any semiconductor product may malfunction under specified conditions. When using XBLW products for system design and overall manufacturing, the buyer is responsible for complying with safety standards and taking appropriate safety measures to avoid risks that may cause personal injury or property damage.
- XBLW products have not been licensed for life support, military, and aerospace applications, and therefore XBLW is not responsible for any consequences arising from the use of this product in these areas.
- If any or all XBLW products (including technical data, services) described or contained in this document are subject to any applicable local export control laws and regulations, they may not be exported without an export license from the relevant authorities in accordance with such laws.
- The specifications of any and all XBLW products described or contained in this document specify the performance, characteristics, and functionality of said products in their standalone state, but do not guarantee the performance, characteristics, and functionality of said products installed in Customer's products or equipment. In order to verify symptoms and conditions that cannot be evaluated in a standalone device, the Customer should ultimately evaluate and test the device installed in the Customer's product device.
- XBLW documentation is only allowed to be copied without any alteration of the content and with the relevant authorization. XBLW assumes no responsibility or liability for altered documents.
- XBLW is committed to becoming the preferred semiconductor brand for customers, and XBLW will strive to provide customers with better performance and better quality products.