

修订 REV NO	标记 MARK	修改摘要 REVISION DESCRIPTION	签名 SIGNATURE	日期 DATE
		NEW DWG		2016-03-12

- SPECIFICATION:
1. RATING: DC 20V 6.5A
 2. CONTACT RESISTANCE: 30mΩ MAX.
 3. INSULATION RESISTANCE: 100 MΩ MIN.
 4. WITHSTAND VOLTAGE: 500 VAC
 5. INSERTION FORCE: 30N MAX.
 6. EXTRACTION FORCE: 6N MIN.
 7. DURABILITY: 5,000 CYCLES

SCHEMATIC	
	2#(+)
	1#(SIGNAL)
	3#(-)

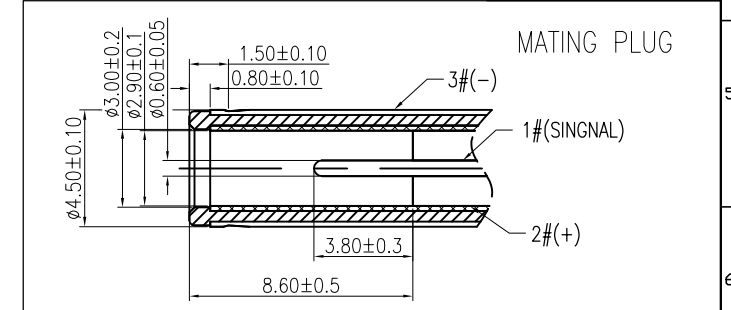

NO.	DESCRIPTION	MATERIAL	REMARKS	QTY
D	SHELL	C5210	Ni 50u"MIN.	1
C	SPRING	C5210	GOLD FLASH/MATTE TIN 80u"/Ni 40u"	1
B	CENTER PIN	C5210	GOLD FLASH/MATTE TIN 80u"/Ni 40u"	1
A	HOUSING	PA10T	BLACK	1

深圳市华德共创科技有限公司
Shenzhen Huade co-create Technology Co., LTD
电话: 0755-27111216 传真: 0755-29940187

-TOLERANCES- UNLESS OTHERWISE SPECIFIED 公差参数表		TITLE: DC Power Jack 4506 大电流8A, 卧式, 产品名称: 高可靠, 四脚插板CL=3.75	
X.X ±0.30	X.X* ±3°	APPD: 核准:	PART NO: 产品编号: DC450060-0355-2H
X.XX ±0.20	X.XX* ±2°	CHECK: 校对: 王建业	DATE SCALE UNIT CODE NUMBER
X.XXX ±0.10	X.XXX* ±1°	DRAW: 绘图: 黄艳兰	2016-03-12 1:1 mm A001

