

SOT-23 Bipolar Transistor 双极型三极管

■ Features 特点

NPN General Purpose 通用

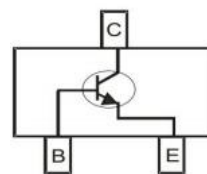

■ Absolute Maximum Ratings 最大额定值

Characteristic 特性参数	Symbol 符号	BC846 A/B/C	BC847 A/B/C	BC848 A/B/C	Unit 单位
Collector-Base Voltage 集电极基极电压	V_{CBO}	80	50	30	V
Collector-Emitter Voltage 集电极发射极电压	V_{CEO}	65	45	30	V
Emitter-Base Voltage 发射极基极电压	V_{EBO}	6	6	5	V
Collector Current 集电极电流	I_C	100			mA
Power dissipation 耗散功率	$P_C(T_a=25^\circ\text{C})$	200			mW
Thermal Resistance Junction-Ambient 热阻	$R_{\theta JA}$	625			$^\circ\text{C}/\text{W}$
Junction and Storage Temperature 结温和储藏温度	T_J, T_{stg}	-55to+150 $^\circ\text{C}$			

■ Device Marking 产品打标

H_{FE}		110-220(A)	200-450(B)	420-800(C)
Mark	BC846	1A	1B	1C
	BC847	1E	1F	1G
	BC848	1J	1K	1L

■Electrical Characteristics 电特性

 (T_A=25°C unless otherwise noted 如无特殊说明, 温度为 25°C)

Characteristic 特性参数		Symbol 符号	Min 最小值	Type 典型值	Max 最大值	Unit 单位
Collector-Base Breakdown Voltage 集电极基极击穿电压 (I _C =10uA, I _E =0)	BC846A/B/C	BV _{CBO}	80	—	—	V
	BC847A/B/C		50			
	BC848A/B/C		30			
Collector-Emitter Breakdown Voltage 集电极发射极击穿电压 (I _C =10mA, I _B =0)	BC846A/B/C	BV _{CEO}	65	—	—	V
	BC847A/B/C		45			
	BC848A/B/C		30			
Emitter-Base Breakdown Voltage 发射极基极击穿电压 (I _E =10uA, I _C =0)		BV _{EBO}	5	—	—	V
Collector-Base Leakage Current 集电极基极漏电流	BC846A/B/C(V _{CB} =70V,I _E =0)	I _{CBO}	—	—	100	nA
	BC847A/B/C(V _{CB} =50V,I _E =0)					
	BC848A/B/C(V _{CB} =30V,I _E =0)					
Emitter-Base Leakage Current 发射极基极漏电流 (V _{EB} =5V, I _C =0)		I _{EBO}	—	—	100	nA
DC Current Gain 直流电流增益 (V _{CE} =5V,I _C =2mA)	BC846A/BC847A/BC848A	H _{FE}	110	180	220	
	BC846B/BC847B/BC848B		200	290	450	
	BC846C/BC847C/BC848C		420	520	800	
Collector-Emitter Saturation Voltage 集电极发射极饱和压降 (I _C =100mA, I _B =5mA)		V _{CE(sat)}	—	—	0.5	V
Base-Emitter Saturation Voltage 基极发射极饱和压降 (I _C =100mA, I _B =5mA)		V _{BE(sat)}	—	—	1.1	V
Transition Frequency 特征频率 (V _{CE} =5V, I _C =10mA)		f _T	100	—	—	MHz
Output Capacitance 输出电容 (V _{CB} =10V, I _E =0, f=1MHz)		C _{ob}	—	4.5	—	pF

■ Typical Characteristic Curve 典型特性曲线

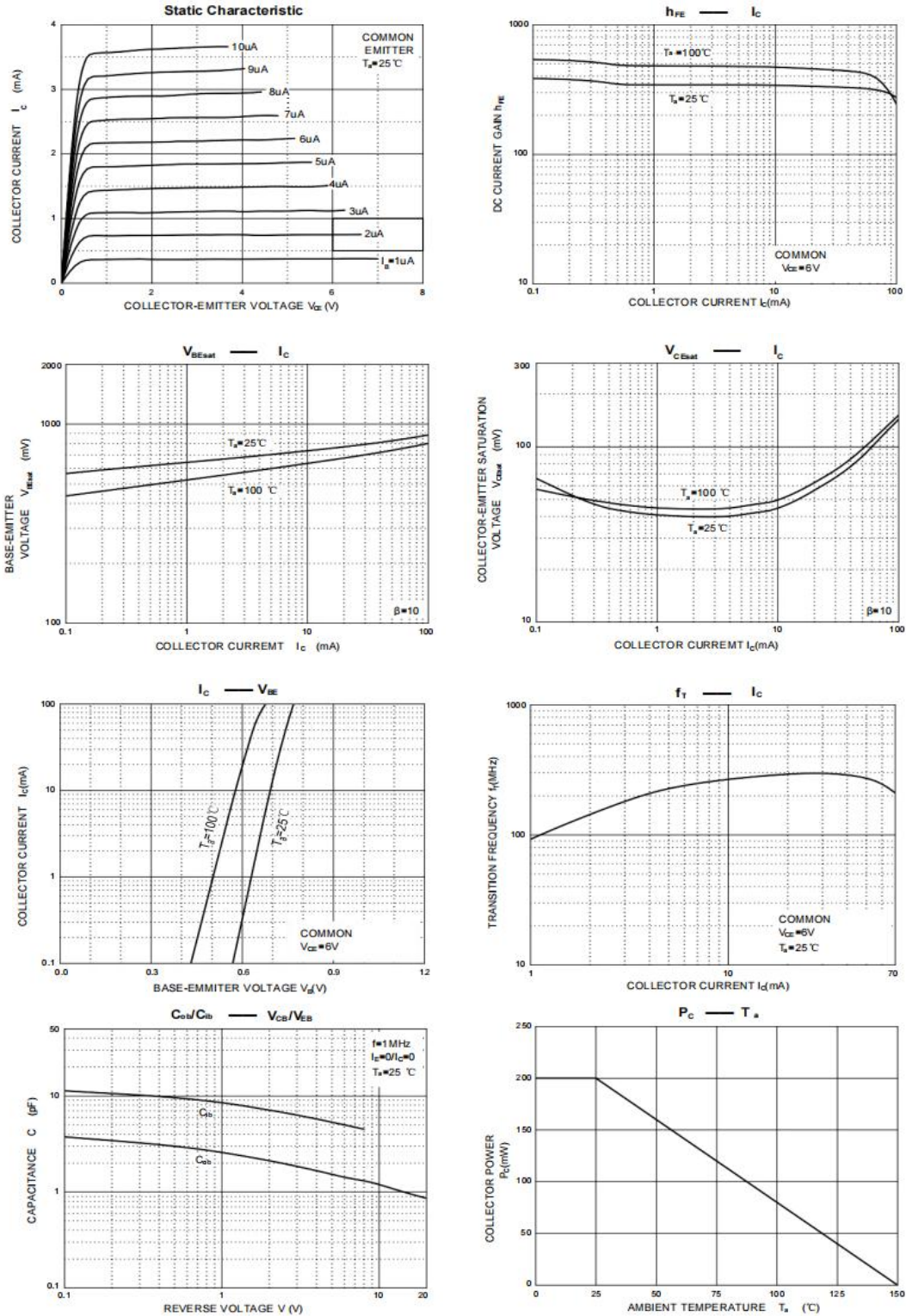



■Dimension 外形封装尺寸

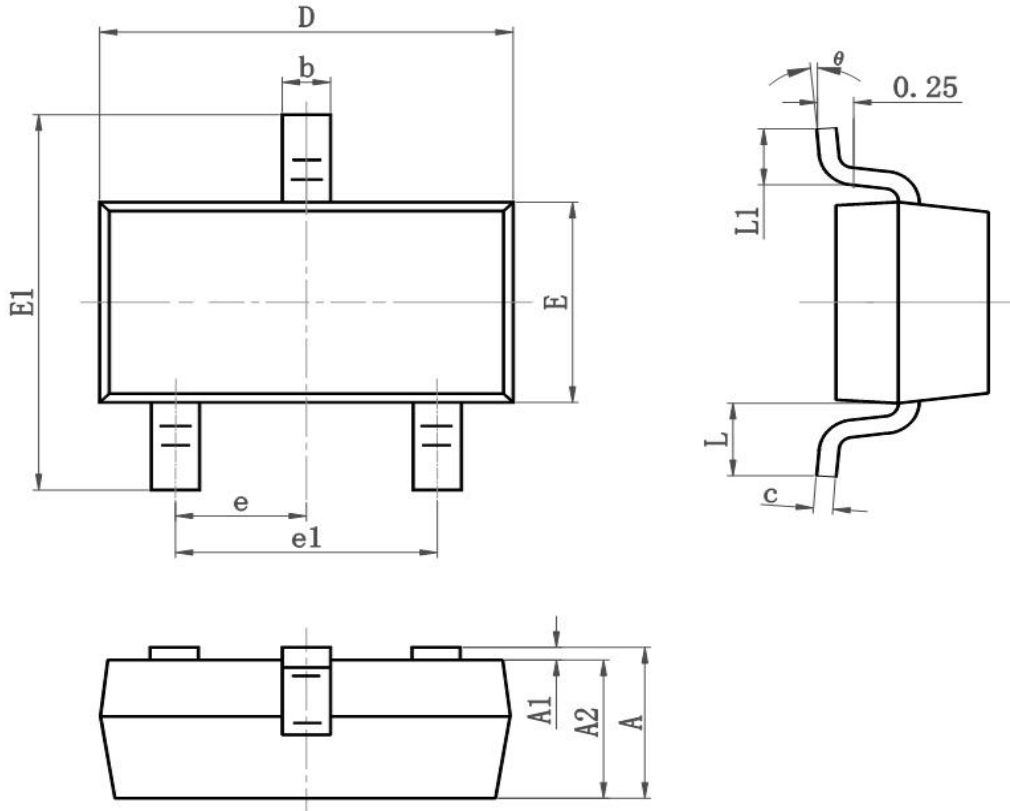

Symbol	Dimensions In Millimeters		Dimensions In Inches	
	Min	Max	Min	Max
A	0.900	1.150	0.035	0.045
A1	0.000	0.100	0.000	0.004
A2	0.900	1.050	0.035	0.041
b	0.300	0.500	0.012	0.020
c	0.080	0.150	0.003	0.006
D	2.800	3.000	0.110	0.118
E	1.200	1.400	0.050	0.055
E1	2.250	2.550	0.089	0.100
e	0.900	1.00	0.035	0.039
e1	1.800	2.000	0.071	0.079
L	0.500	0.600	0.020	0.024
L1	0.300	0.500	0.012	0.020
θ	0°	8°	0°	8°