

3D View

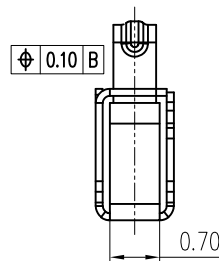

NOTES

- (1) MATERIAL: SUS-301 THICKNESS=0.10mm
- (2) PRODUCT SPECIFICATIONS:
 - 2-1: RATED CURRENT: 1.0A
 - 2-2: VOLTAGE RATING: 1.50V
 - 2-3: CONTACT RESISTANCE: 80mΩ/MAX
 - 2-4: WELDING THRUST: ≥3KG
 - 2-5: OPERATING TEMPERATURE: -40°C~+85°C
 - 2-6: DURABILITY: 1500 CYCLES
- (3) SALT SPRAY: 24 HOURS
- (4) FINISH: 50u"Min NICKEL UNDERPLATING OVER ALL.
- (5) REQUIREMENTS
 - 5-1: TERMINAL TO EAT FULL TIN, NOT PEELING WELDING OBVIOUS COLOR AND OTHER ADVERSE
 - 5-2: ROHS, REACH, HF HALOGEN ADVERSE OF DOMESTIC AND INTERNATIONAL ENVIRONMENTAL REQUIREMENTS

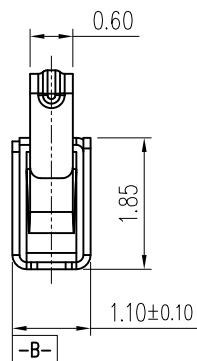
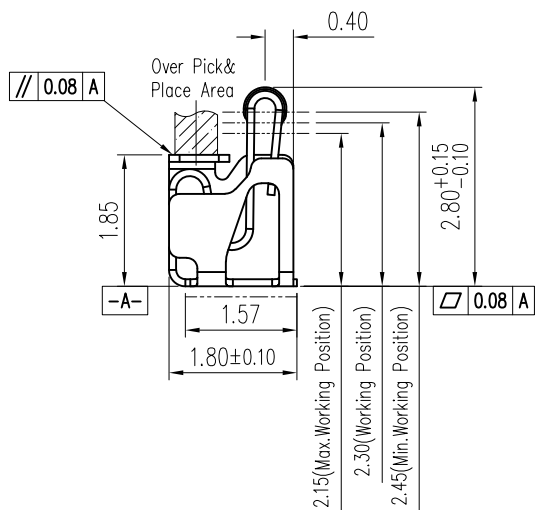
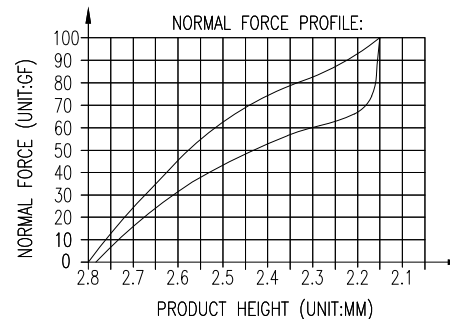
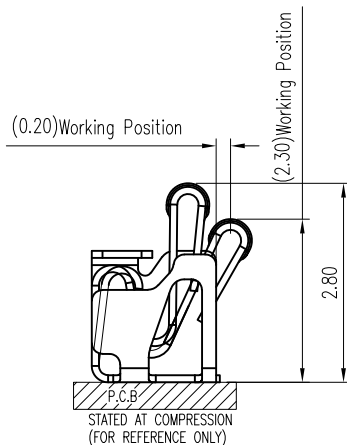
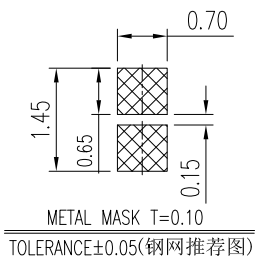
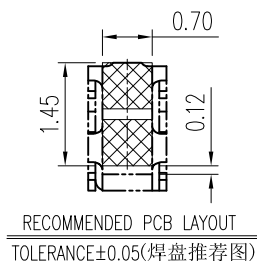

 深圳市华宇创精密电子有限公司			
TOLERANCE: X.X ±0.30 X.XX ±0.25 X.XXX ±0.15 X.' ±2' X.X' ±0.5'	DRAWN BY : 陈一鸣	DATE : 2014-02-23	PART NAME: 天线弹片 L1.80*W1.10*H2.80
	CHECKED BY: 马跃	DATE : 2014-02-23	PART NO. HYCW-TXT181128A
UNIT: mm [inch] SCALE: 1:1 SIZE: A4	APPROVED BY: 邱敏	DATE : 2014-02-23	DRAW NO: HYC-2412191458
			SHEET NO. 1 OF 1