

Features

- Wide supply voltage range from 1.2 V to 3.6 V
- CMOS low power dissipation
- Inputs accept voltages up to 5.5 V
- Direct interface with TTL levels
- Latch-up performance exceeds 250 mA
- Packaging: TSSOP-14

Applications

- S-R latch
- Alarm detection circuit
- Tampering detection circuit

General Description

The 74LVC10A provides three 3-input NAND functions. Inputs can be driven from either 3.3 V or 5 V devices. This feature allows the use of these devices as translators in mixed 3.3 V and 5 V applications.

PIN CONFIGURATIONS (Top view)

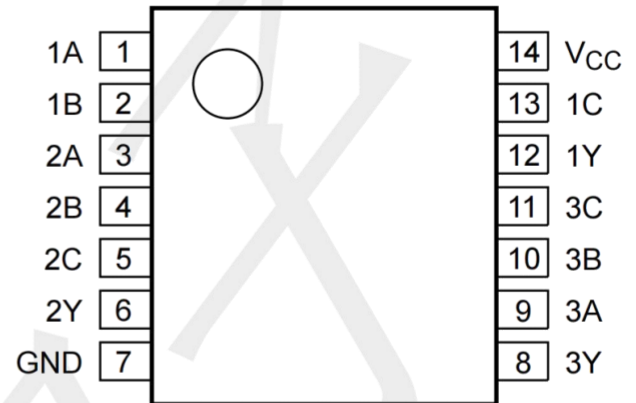

LOGIC SYMBOL

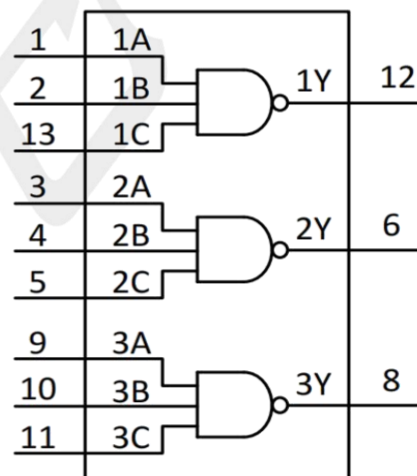

PIN DESCRIPTION

PIN NO.	PIN NAME	DESCRIPTION	PIN NO.	PIN NAME	DESCRIPTION
1	1A	Data input	8	3Y	Data output
2	1B	Data input	9	3A	Data input
3	2A	Data input	10	3B	Data input
4	2B	Data input	11	3C	Data input
5	2C	Data input	12	1Y	Data output
6	2Y	Data output	13	1C	Data input
7	GND	ground (0 V)	14	V _{CC}	supply voltage

Functional diagram

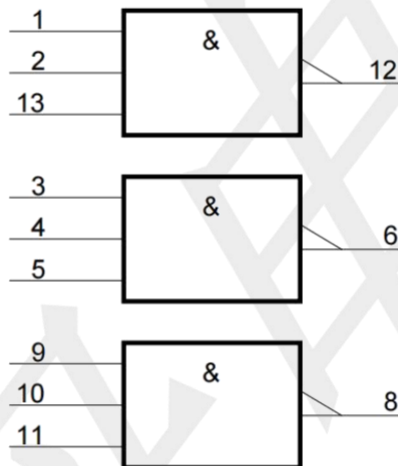
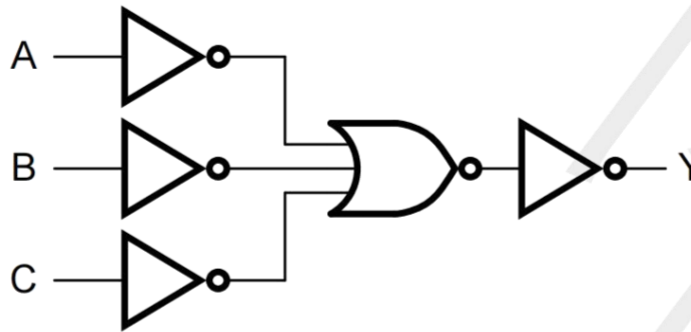

Function table

Input			Output
nA	nB	nC	nY
L	X	X	H
X	L	X	H
X	X	L	H
H	H	H	L

Note: H=HIGH voltage level; L=LOW voltage level; X=don't care.

ABSOLUTE MAXIMUM RATINGS

(Voltages are referenced to GND(ground=0V), unless otherwise specified.)

Parameter	Symbol	Conditions	Min	Max	Unit
Supply voltage	V_{CC}		-0.5	+6.5	V
Input clamping current	I_{IK}	$V_I < 0V$	-50	--	mA
Output clamping current	I_{OK}	$V_O < 0V$ or $V_O > V_{CC}$	--	± 20	mA
Output current	I_O	$-0.5V < V_O < V_{CC} + 0.5V$	--	± 50	mA
Supply current	I_{CC}		--	100	mA
Ground current	I_{GND}		-100	--	mA
Total power dissipation	P_{tot}		--	500	mW
Storage temperature	T_{stg}		-65	+150	°C
Soldering temperature	T_L		260		°C

Recommended operating conditions

Parameter	Symbol	Conditions	Min	Typ	Max	Unit
Supply voltage	V_{CC}		1.65	--	3.6	V
		functiona	1.2	--	--	V
Input voltage	V_I		0	--	5.5	V
Input transition rise and fall rate	$\Delta t/\Delta V$	$V_{CC}=1.65V$	--	--	20	ns/V
		$V_{CC}=2.7V$	--	--	15	ns/V
		$V_{CC}=3.6V$	--	--	10	ns/V
Ambient temperature	T_{amb}		-40	--	+125	°C

Static characteristics

At recommended operating conditions. Voltages are referenced to GND (ground = 0 V)

Symbol	Parameter	Conditions	-40 °C to +85 °C			-40 °C to +125 °C		Unit
			Min	Typ	Max	Min	Max	
V_{IH}	HIGH-level input voltage	$V_{CC} = 1.2\text{ V}$	1.08	--	--	1.08	--	V
		$V_{CC} = 1.65\text{ V to }1.95\text{ V}$	$0.65 \times V_{CC}$	--	--	$0.65 \times V_{CC}$	--	V
		$V_{CC} = 2.3\text{ V to }2.7\text{ V}$	1.7	--	--	1.7	--	V
		$V_{CC} = 2.7\text{ V to }3.6\text{ V}$	2.0	--	--	2.0	--	V
V_{IL}	LOW-level input voltage	$V_{CC} = 1.2\text{ V}$	--	--	0.12	--	0.12	V
		$V_{CC} = 1.65\text{ V to }1.95\text{ V}$	--	--	$0.35 \times V_{CC}$	--	$0.35 \times V_{CC}$	V
		$V_{CC} = 2.3\text{ V to }2.7\text{ V}$	--	--	0.7	--	0.7	V
		$V_{CC} = 2.7\text{ V to }3.6\text{ V}$	--	--	0.8	--	0.8	V
V_{OH}	HIGH-level output voltage ($V_I = V_{IH}$ or V_{IL})	$I_o = -100\ \mu\text{A}; V_{CC} = 1.65\text{ V to }3.6\text{ V}$	$V_{CC} - 0.2$	--	--	$V_{CC} - 0.3$	--	V
		$I_o = -4\text{ mA}; V_{CC} = 1.65\text{ V}$	1.2	--	--	1.05	--	V
		$I_o = -8\text{ mA}; V_{CC} = 2.3\text{ V}$	1.8	--	--	1.65	--	V
		$I_o = -12\text{ mA}; V_{CC} = 2.7\text{ V}$	2.2	--	--	2.05	--	V
		$I_o = -18\text{ mA}; V_{CC} = 3.0\text{ V}$	2.4	--	--	2.25	--	V
		$I_o = -24\text{ mA}; V_{CC} = 3.0\text{ V}$	2.2	--	--	2.0	--	V
V_{OL}	LOW-level output voltage ($V_I = V_{IH}$ or V_{IL})	$I_o = 100\ \mu\text{A}; V_{CC} = 1.65\text{ V to }3.6\text{ V}$	--	--	0.2	--	0.3	V
		$I_o = 4\text{ mA}; V_{CC} = 1.65\text{ V}$	--	--	0.45	--	0.65	V
		$I_o = 8\text{ mA}; V_{CC} = 2.3\text{ V}$	--	--	0.6	--	0.8	V
		$I_o = 12\text{ mA}; V_{CC} = 2.7\text{ V}$	--	--	0.4	--	0.6	V
		$I_o = 24\text{ mA}; V_{CC} = 3.0\text{ V}$	--	--	0.55	--	0.8	V
I_I	input leakage current	$V_{CC} = 3.6\text{ V}; V_I = 5.5\text{ V}$ or GND	--	± 0.1	± 5	--	± 20	μA
I_{CC}	supply current	$V_{CC} = 3.6\text{ V}; V_I = V_{CC}$ or GND; $I_o = 0\text{ A}$	--	0.1	10	--	40	μA
ΔI_{CC}	additional supply current	per input pin; $V_{CC} = 2.7\text{ V to }3.6\text{ V}; V_I = V_{CC} - 0.6\text{ V}; I_o = 0\text{ A}$	--	5	500	--	5000	μA
C_I	input capacitance	$V_{CC} = 0\text{ V to }3.6\text{ V}; V_I = \text{GND to }V_{CC}$	--	4.0	--	--	--	pF

Dynamic characteristics

Voltages are referenced to GND (ground = 0 V)

Symbol	Parameter	Conditions	-40 °C to +85 °C			-40 °C to +125 °C		Unit
			Min	Typ	Max	Min	Max	
t_{pd}	propagation delay	nA, nB, nC to nY; see						
		$V_{CC} = 1.2\text{ V}$	--	13	--	--	--	ns
		$V_{CC} = 1.65\text{ V to }1.95\text{ V}$	0.5	4.5	11.2	0.5	12.9	ns
		$V_{CC} = 2.3\text{ V to }2.7\text{ V}$	1.0	2.7	6.3	1.0	7.4	ns
		$V_{CC} = 2.7\text{ V}$	1.5	2.8	6.7	1.5	7.8	ns
		$V_{CC} = 3.0\text{ V to }3.6\text{ V}$	1.5	2.4	5.7	1.5	6.6	ns
C_{PD}	power	per gate; $V_I = \text{GND to } V_{CC}$						
	dissipation	$V_{CC} = 1.65\text{ V to }1.95\text{ V}$	--	2.9	--	--	--	pF
	capacitance	$V_{CC} = 2.3\text{ V to }2.7\text{ V}$	--	6.0	--	--	--	pF
	e	$V_{CC} = 3.0\text{ V to }3.6\text{ V}$	--	8.8	--	--	--	pF

1, Typical values are measured at $T_{amb} = 25\text{ °C}$ and $V_{CC} = 1.2\text{ V}, 1.8\text{ V}, 2.5\text{ V}, 2.7\text{ V},$ and 3.3 V respectively.

2, t_{pd} is the same as t_{PLH} and t_{PHL} .

3, C_{PD} is used to determine the dynamic power dissipation (P_D in μW). $P_D = C_{PD} \times V_{CC}^2 \times f_i \times N + \Sigma(C_L \times V_{CC}^2 \times f_o)$ where:

f_i = input frequency in MHz; f_o = output frequency in MHz
 C_L = output load capacitance in pF

V_{CC} = supply voltage in Volts

N = number of inputs

switching

$\Sigma(C_L \times V_{CC}^2 \times f_o)$ = sum of the outputs

Waveforms and test circuit

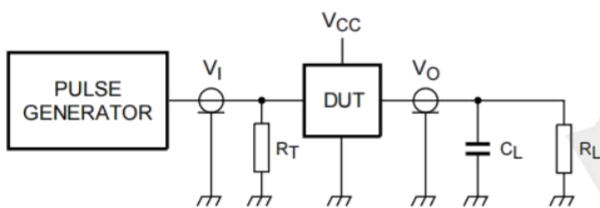
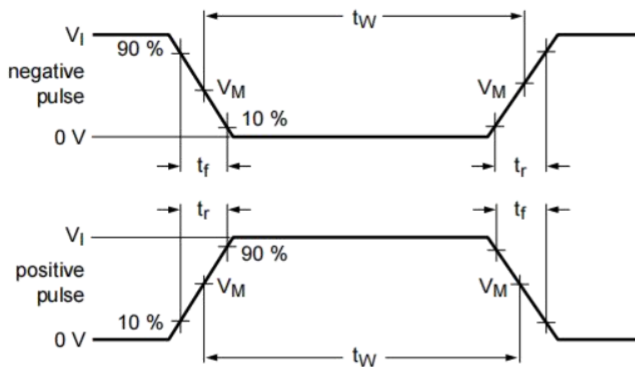

Test data is given in Definitions for test circuit:

R_L = Load resistance.

C_L = Load capacitance including jig and probe capacitance.

R_T = Termination resistance should be equal to output impedance Z_o of the pulse generator.

Test circuit for measuring switching times

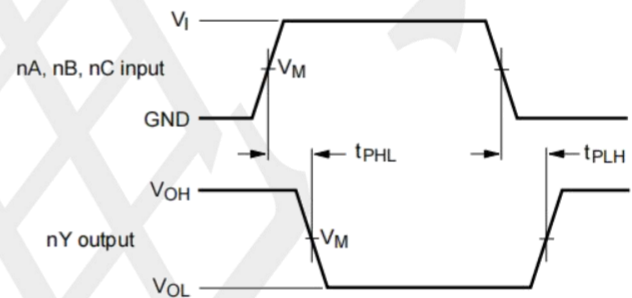

$V_M = 1.5 \text{ V}$ at $V_{CC} \geq 2.7 \text{ V}$

$V_M = 0.5 \times V_{CC}$ at $V_{CC} < 2.7 \text{ V}$.

V_{OL} and V_{OH} are typical output voltage levels that occur with the output load.

Input (nA, nB and nC) to output (nY) propagation delays

Test data

Supply voltage	Input		Load	
	V_I	t_r, t_f	C_L	R_L
1.2 V	V_{CC}	$\leq 2 \text{ ns}$	30 pF	1 k Ω
1.65 V to 1.95 V	V_{CC}	$\leq 2 \text{ ns}$	30 pF	1 k Ω
2.3 V to 2.7 V	V_{CC}	$\leq 2 \text{ ns}$	30 pF	500 Ω
2.7 V	2.7 V	$\leq 2.5 \text{ ns}$	50 pF	500 Ω
3.0 V to 3.6 V	2.7 V	$\leq 2.5 \text{ ns}$	50 pF	500 Ω

Package information

TSSOP-14

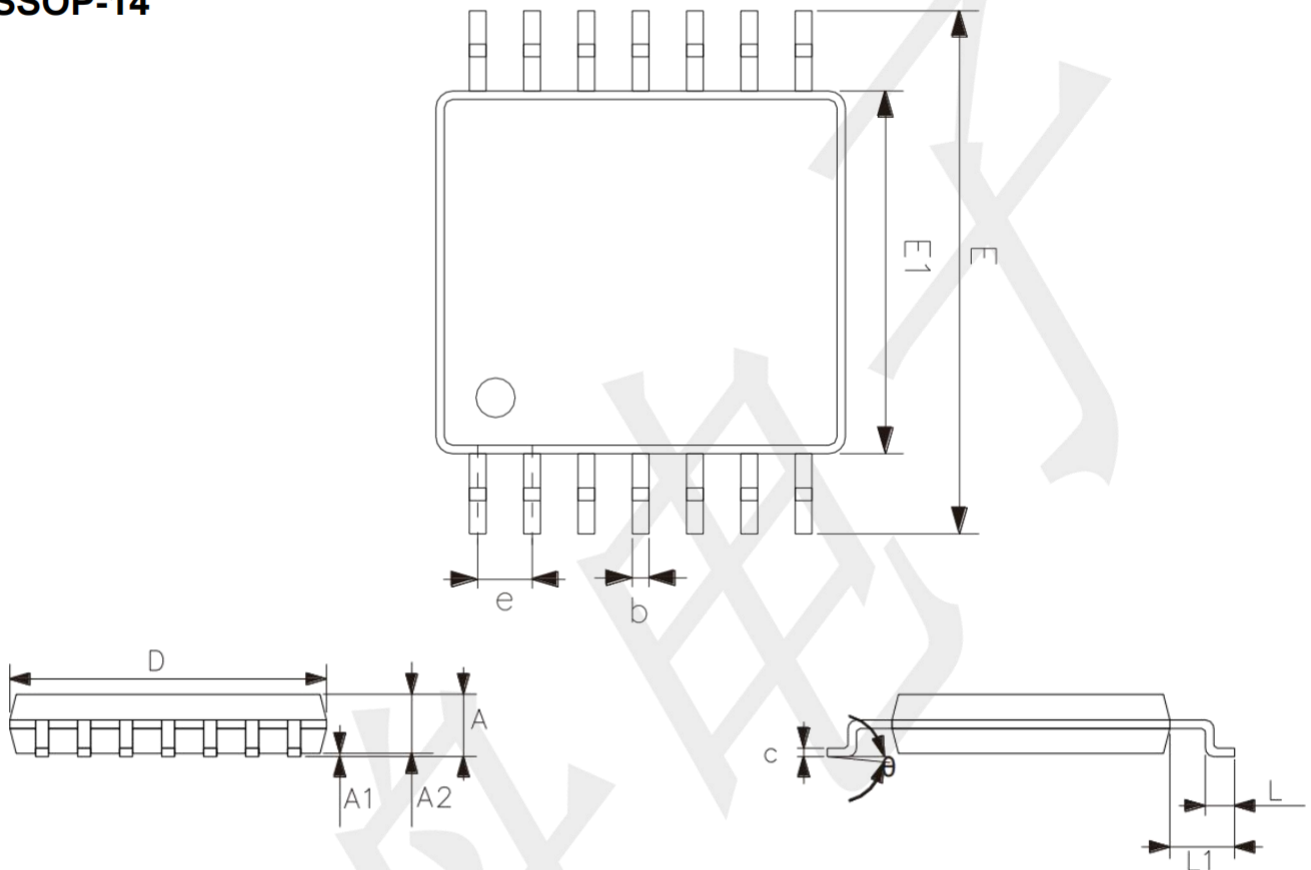

Symbol	Dimensions (mm)	
	Min.	Max.
A	-	1.20
A1	0.05	0.15
A2	0.80	1.05
b	0.19	0.30
c	0.09	0.20
D	4.90	5.10
E1	4.30	4.50
E	6.20	6.60
e	0.65	
L	0.45	0.75
L1	1.00	
θ	0°	8°