

### Product Summary

- $V_{DS} = 60V, I_D = 0.3A$   
 $R_{DS(ON)} < 3\Omega @ V_{GS}=5V$   
 $R_{DS(ON)} < 2\Omega @ V_{GS}=10V$

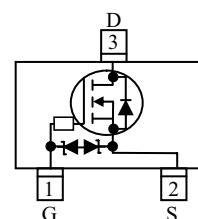
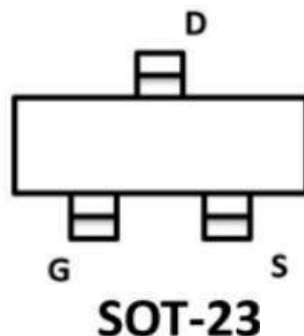
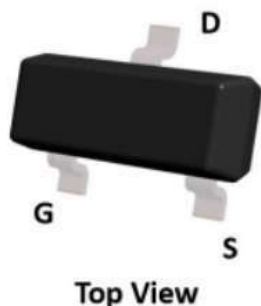

### General Description

- Trench Power LV MOSFET technology
- High Power and current handing capability

### Applications

- PWM application
- Load switch

**Marking: 72K**

ABSOLUTE MAXIMUM RATINGS ( $T_A=25^\circ C$ , unless otherwise specified.)

PARAMETER		SYMBOL	RATINGS	UNIT
Drain-Source Voltage		$V_{DSS}$	60	V
Drain-Gate Voltage ( $R_{GS} \leq 1M\Omega$ )		$V_{DGR}$	60	V
Gate Source Voltage	Continuous	$V_{GSS}$	$\pm 20$	V
Drain Current	Continuous	$I_D$	300	mA
	Pulsed		900	
Power Dissipation		$P_D$	200	mW
Derated Above $25^\circ C$			1.6	mW/ $^\circ C$
Junction Temperature		$T_J$	+ 150	$^\circ C$
Storage Temperature		$T_{STG}$	-55 ~ +150	$^\circ C$

Note: Absolute maximum ratings are those values beyond which the device could be permanently damaged. Absolute maximum ratings are stress ratings only and functional device operation is not implied.

### THERMAL DATA

PARAMETER	SYMBOL	RATINGS	UNIT
Junction to Ambient	$\theta_{JA}$	625	$^\circ C/W$
Junction to Case	$\theta_{JC}$	215	$^\circ C/W$

ELECTRICAL CHARACTERISTICS ( $T_A=25^\circ\text{C}$ , unless otherwise specified)

PARAMETER	SYMBOL	TEST CONDITIONS	MIN	TYP	MAX	UNIT
<b>OFF CHARACTERISTICS</b>						
Drain-Source Breakdown Voltage	$BV_{DSS}$	$V_{GS}=0V, I_D=10\mu A$	60			V
Drain-Source Leakage Current	$I_{DSS}$	$V_{DS}=60V, V_{GS}=0V$			1	$\mu A$
Gate-Source Leakage Current	$I_{GSSF}$	$V_{GS}=20V, V_{DS}=0V$			10	$\mu A$
	$I_{GSSR}$	$V_{GS}=-20V, V_{DS}=0V$			-10	$\mu A$
<b>ON CHARACTERISTICS (Note)</b>						
Gate Threshold Voltage	$V_{GS(TH)}$	$V_{GS}=V_{DS}, I_D=250\mu A$	1.1	1.4	2.2	V
Static Drain-Source On-Resistance	$R_{DS(ON)}$	$V_{GS}=10V, I_D=300mA$		1.6	2.0	$\Omega$
		$V_{GS}=4.5V, I_D=200mA$		2.4	3.0	$\Omega$
<b>DYNAMIC CHARACTERISTICS</b>						
Input Capacitance	$C_{ISS}$	$V_{DS}=25V, V_{GS}=0V, f=1.0MHz$			50	pF
Output Capacitance	$C_{OSS}$				25	pF
Reverse Transfer Capacitance	$C_{RSS}$				5	pF
Turn-On Time	$t_{ON}$	$V_{DD}=30V, R_L=150\Omega, I_D=200mA,$			20	nS
Turn-Off Time	$t_{OFF}$	$V_{GS}=10V, R_G=25\Omega$			20	nS
<b>DRAIN-SOURCE DIODE CHARACTERISTICS AND MAXIMUM RATINGS</b>						
Maximum Continuous Drain-Source Diode Forward Current	$I_S$				300	mA
Maximum Pulsed Drain-Source Diode Forward Current	$I_{SM}$				0.95	A
Drain-Source Diode Forward Voltage	$V_{SD}$	$V_{GS}=0V, I_S=300mA$ (Note)		0.88	1.5	V

Note: Pulse Test: Pulse Width  $\leq 300\mu s$ , Duty Cycle  $\leq 2.0\%$

WPMtek

TYPICAL CHARACTERISTICS

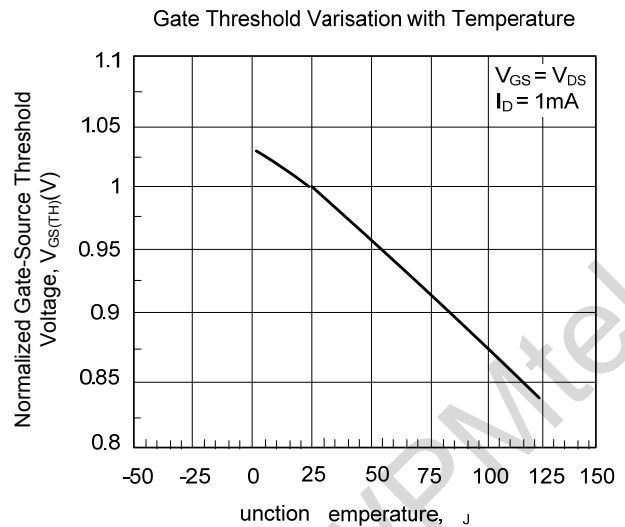
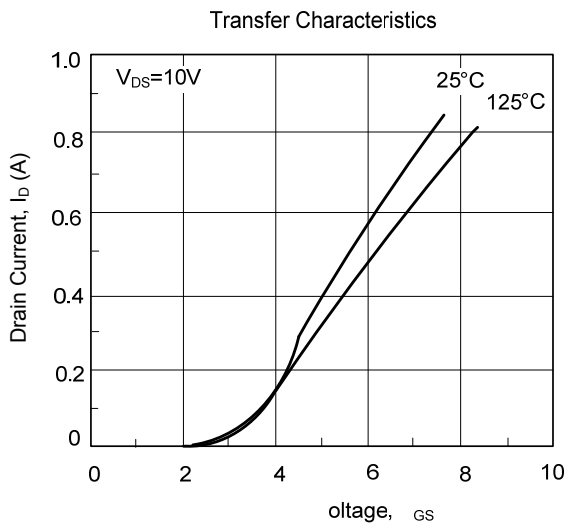
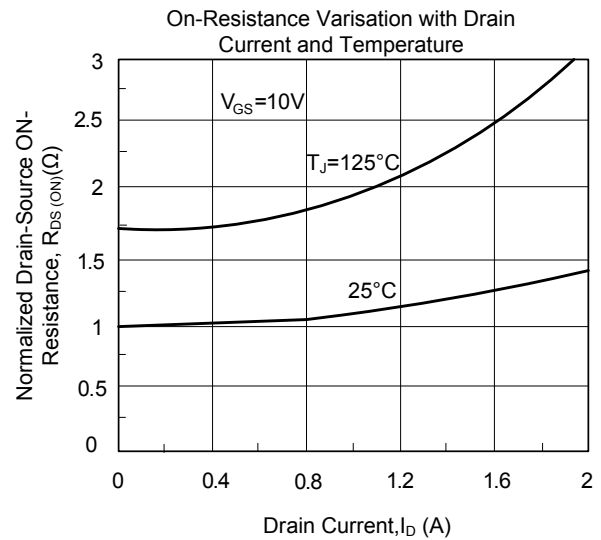
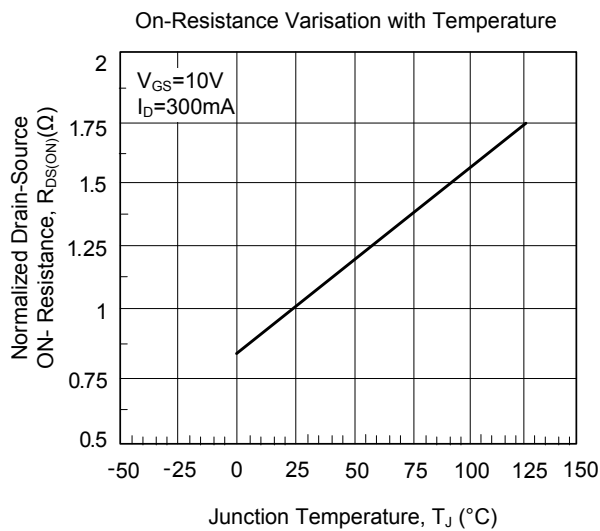
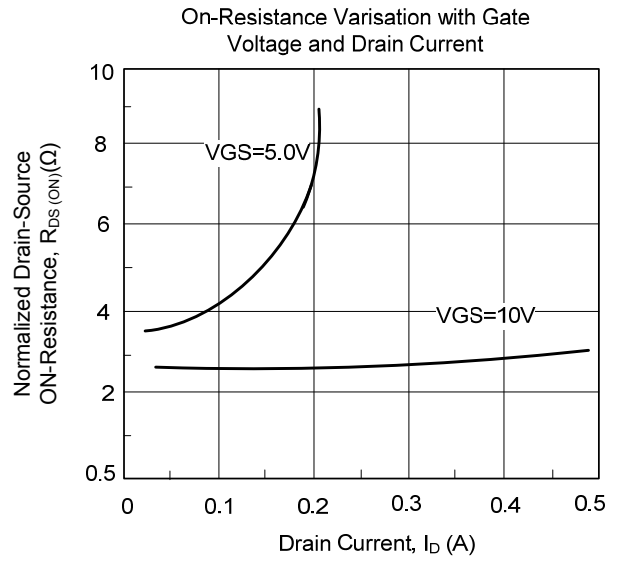
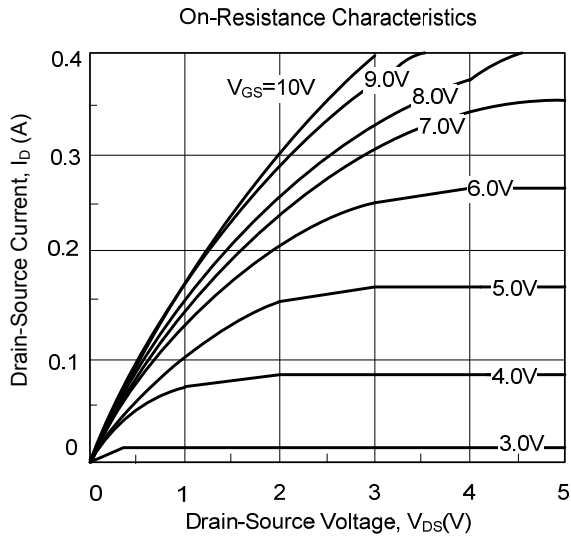

TYPICAL CHARACTERISTICS(Cont.)

Breakdown Voltage Variation with Temperature

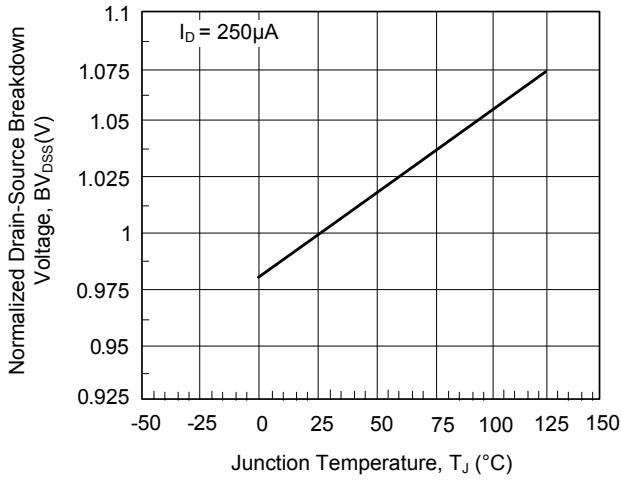

Body Diode Forward Voltage Variation with Temperature

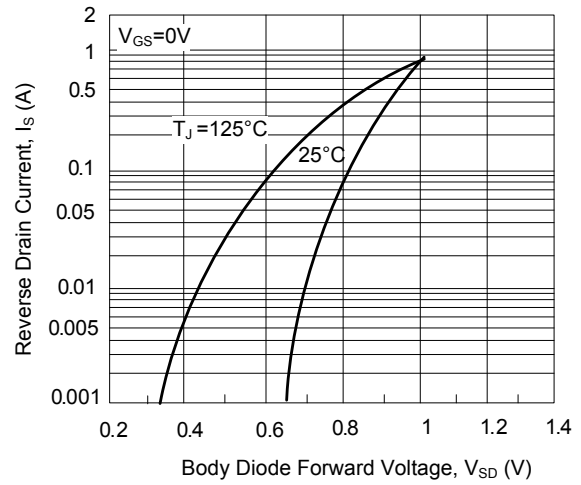

Capacitance Characteristics

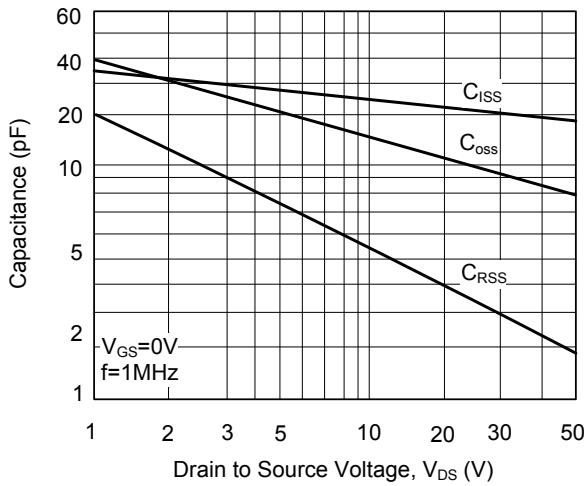

Gate Charge Characteristics

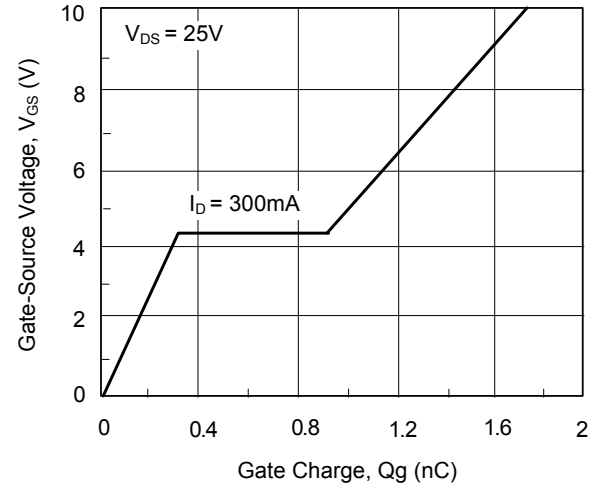

Maximum Safe Operating Area

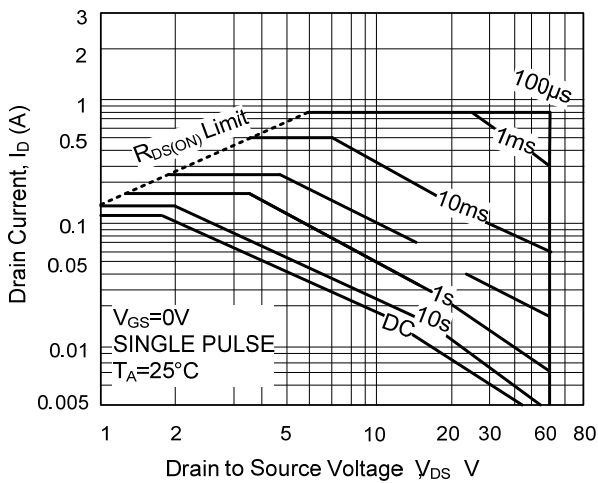

Transient Thermal Response Curve

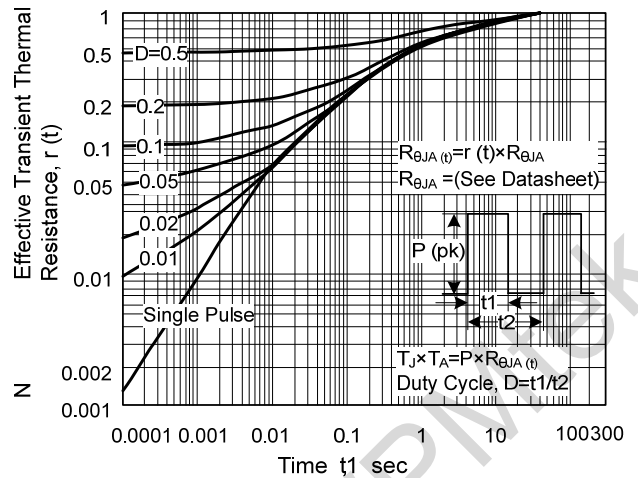

TEST CIRCUIT AND WAVEFORM

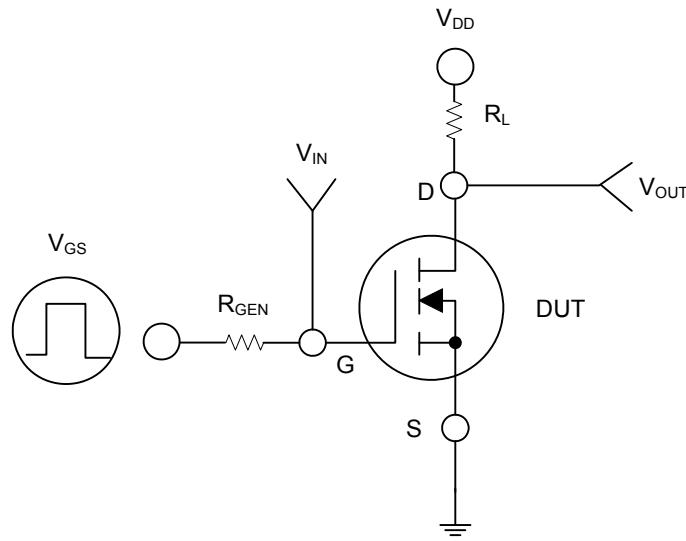

Fig. 1

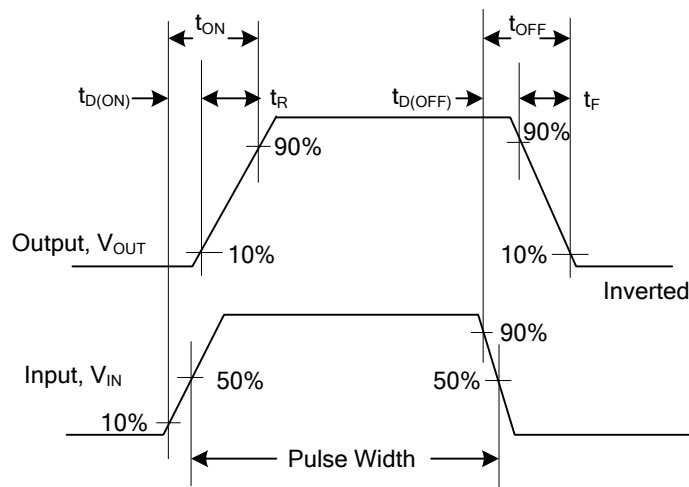
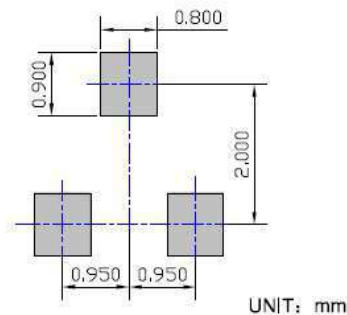
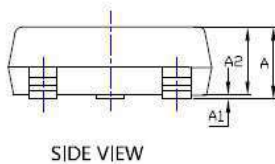
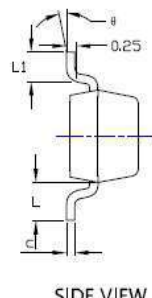
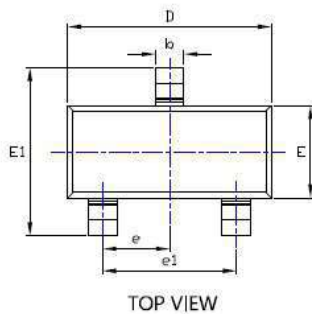

Fig. 2 Switching Waveforms

WPMtek

**SOT-23 Package information**



SUGGESTED SOLDER PAD LAYOUT

SYMBOL	DIMENSIONS					
	INCHES			MILLimeter		
	MIN.	NOM.	MAX.	MIN.	NOM.	MAX.
A	0.035	---	0.045	0.900	---	1.150
A1	0.000	---	0.004	0.000	---	0.100
A2	0.035	0.038	0.041	0.900	0.975	1.050
b	0.012	0.016	0.020	0.300	0.400	0.500
c	0.004	---	0.008	0.100	---	0.200
D	0.110	0.114	0.118	2.800	2.900	3.000
E	0.047	0.051	0.055	1.200	1.300	1.400
E1	0.089	0.094	0.100	2.250	2.400	2.550
e	0.037 TYP			0.950 TYP		
e1	0.071	0.075	0.079	1.800	1.900	2.000
L	0.022 REF			0.550 REF		
L1	0.012	0.016	0.200	0.300	0.400	0.500
φ	0*	---	8*	0*	---	8*

NOTE:

1. PACKAGE BODY SIZES EXCLUDE MOLD FLASH AND GATE BURRS.
2. TOLERANCE 0.1mm UNLESS OTHERWISE SPECIFIED.
3. THE PAD LAYOUT IS FOR REFERENCE PURPOSES ONLY.

WPMtek reserves the right to make changes to the product specification and data in this document without notice. WPMtek makes no warranty, representation or guarantee regarding the suitability of its products for any particular purpose, nor does WPMtek assume any liability arising from the application or use of any products or circuits, and specifically disclaims any and all liability, including without limitation special, consequential or incidental damages. Any enquiry, please write to sales@wpmtek.com for further information.