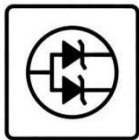


# MSKSEMI 美森科

SEMICONDUCTOR



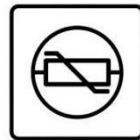
ESD



TVS



TSS



MOV



GDT



PLED

**MMUN2211LT1G-MS-MMUN2241LT1G-MS**

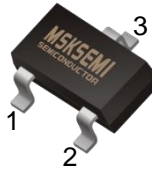
**Product specification**

NPN Silicon Epitaxial Planar Transistor

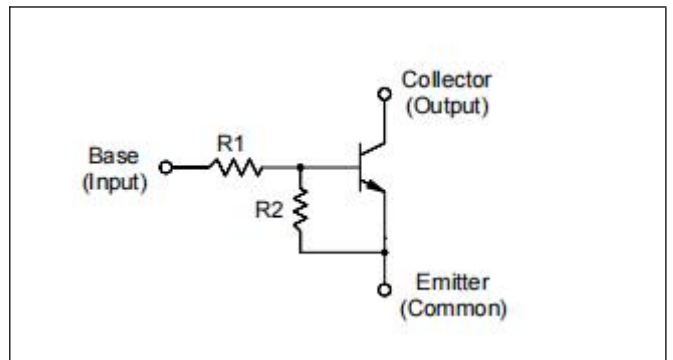
**FEATURE**

for switching and interface circuit and drive circuit applications

**Reference News**

<b>SOT-23</b>	
	<ol style="list-style-type: none"> <li>1. Base</li> <li>2. Emitter</li> <li>3. Collector</li> </ol>

**Pin Configuration**



**MARKING**

MMUN2211LT1G-MS	MMUN2212LT1G-MS	MMUN2213LT1G-MS	MMUN2214LT1G-MS	MMUN2215LT1G-MS
<b>11</b>	<b>A8B</b>	<b>A8C</b>	<b>A8D</b>	<b>A8E</b>

MMUN2216LT1G-MS	MMUN2230LT1G-MS	MMUN2231LT1G-MS	MMUN2232LT1G-MS	MMUN2233LT1G-MS
<b>A8F</b>	<b>A8G</b>	<b>A8H</b>	<b>A8J</b>	<b>A8K</b>

MMUN2234LT1G-MS	MMUN2235LT1G-MS	MMUN2238LT1G-MS	MMUN2241LT1G-MS
<b>A8L</b>	<b>A8M</b>	<b>A8R</b>	<b>A8U</b>

**Resistor Values**

Type	R1 (K)	R2 (K)
MMUN2211LT1G-MS	10	10
MMUN2212LT1G-MS	22	22
MMUN2213LT1G-MS	47	47
MMUN2214LT1G-MS	10	47
MMUN2215LT1G-MS	10	∞
MMUN2216LT1G-MS	4.7	∞
MMUN2230LT1G-MS	1	1
MMUN2231LT1G-MS	2.2	2.2
MMUN2232LT1G-MS	4.7	4.7
MMUN2233LT1G-MS	4.7	47
MMUN2234LT1G-MS	22	47
MMUN2235LT1G-MS	2.2	47
MMUN2238LT1G-MS	2.2	∞
MMUN2241LT1G-MS	100	∞

**Absolute Maximum Ratings (T<sub>a</sub> = 25 °C)**

Parameter	Symbol	Value	Unit
Collector Base Voltage	V <sub>CBO</sub>	50	V
Collector Emitter Voltage	V <sub>CEO</sub>	50	V
Collector Current	I <sub>c</sub>	100	mA
Total Power Dissipation	P <sub>tot</sub>	200	mW
Junction Temperature	T <sub>j</sub>	150	°C
Storage Temperature Range	T <sub>s</sub>	- 55 to + 150	°C

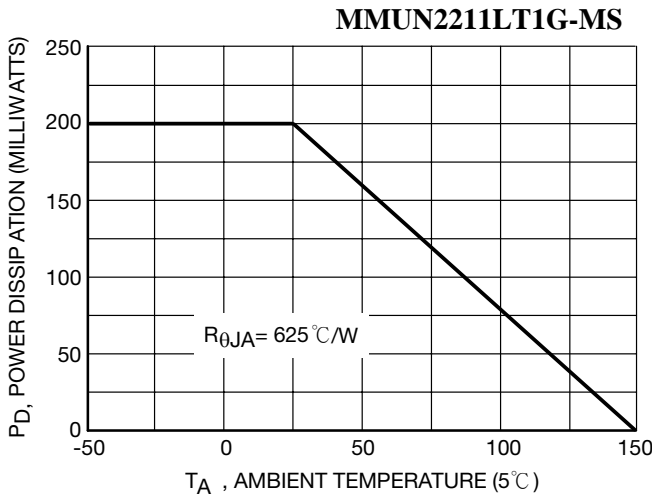
**Characteristics at  $T_a = 25\text{ }^\circ\text{C}$** 

Parameter	Symbol	Min.	Max.	Unit	
DC Current Gain at $V_{CE} = 10\text{ V}$ , $I_C = 5\text{ mA}$	MMUN2211LT1G-MS	$h_{FE}$	35	-	-
	MMUN2212LT1G-MS	$h_{FE}$	60	-	-
	MMUN2213LT1G-MS	$h_{FE}$	80	-	-
	MMUN2214LT1G-MS	$h_{FE}$	80	-	-
	MMUN2215LT1G-MS	$h_{FE}$	160	-	-
	MMUN2216LT1G-MS	$h_{FE}$	160	-	-
	MMUN2230LT1G-MS	$h_{FE}$	3	-	-
	MMUN2231LT1G-MS	$h_{FE}$	8	-	-
	MMUN2232LT1G-MS	$h_{FE}$	15	-	-
	MMUN2233LT1G-MS	$h_{FE}$	80	-	-
	MMUN2234LT1G-MS	$h_{FE}$	80	-	-
	MMUN2235LT1G-MS	$h_{FE}$	80	-	-
	MMUN2238LT1G-MS	$h_{FE}$	160	-	-
	MMUN2241LT1G-MS	$h_{FE}$	160	-	-
Collector Base Cutoff Current at $V_{CB} = 50\text{ V}$	$I_{CBO}$	-	100	nA	
Collector Emitter Cutoff Current at $V_{CE} = 50\text{ V}$	$I_{CEO}$	-	500	nA	
Emitter Base Cutoff Current at $V_{EB} = 6\text{ V}$	MMUN2211LT1G-MS	$I_{EBO}$	-	0.5	mA
	MMUN2212LT1G-MS	$I_{EBO}$	-	0.2	mA
	MMUN2213LT1G-MS	$I_{EBO}$	-	0.1	mA
	MMUN2214LT1G-MS	$I_{EBO}$	-	0.2	mA
	MMUN2215LT1G-MS	$I_{EBO}$	-	0.9	mA
	MMUN2216LT1G-MS	$I_{EBO}$	-	1.9	mA
	MMUN2230LT1G-MS	$I_{EBO}$	-	4.3	mA
	MMUN2231LT1G-MS	$I_{EBO}$	-	2.3	mA
	MMUN2232LT1G-MS	$I_{EBO}$	-	1.5	mA
	MMUN2233LT1G-MS	$I_{EBO}$	-	0.18	mA
	MMUN2234LT1G-MS	$I_{EBO}$	-	0.13	mA
	MMUN2235LT1G-MS	$I_{EBO}$	-	0.2	mA
	MMUN2238LT1G-MS	$I_{EBO}$	-	4	mA
	MMUN2241LT1G-MS	$I_{EBO}$	-	0.1	mA
Collector Base Breakdown Voltage at $I_C = 10\text{ }\mu\text{A}$	$V_{(BR)CBO}$	50	-	V	
Collector Emitter Breakdown Voltage at $I_C = 2\text{ mA}$	$V_{(BR)CEO}$	50	-	V	
Collector Emitter Saturation Voltage at $I_C = 10\text{ mA}$ , $I_B = 0.3\text{ mA}$ at $I_C = 10\text{ mA}$ , $I_B = 5\text{ mA}$  at $I_C = 10\text{ mA}$ , $I_B = 1\text{ mA}$	MMUN2230LT1G-MS	$V_{CEsat}$	-	0.25	V
	MMUN2231LT1G-MS	$V_{CEsat}$	-	0.25	V
	MMUN2215LT1G-MS	$V_{CEsat}$	-	0.25	V
	MMUN2216LT1G-MS	$V_{CEsat}$	-	0.25	V
	MMUN2232LT1G-MS	$V_{CEsat}$	-	0.25	V
	MMUN2233LT1G-MS	$V_{CEsat}$	-	0.25	V
	MMUN2234LT1G-MS	$V_{CEsat}$	-	0.25	V
	MMUN2235LT1G-MS	$V_{CEsat}$	-	0.25	V
	MMUN2238LT1G-MS	$V_{CEsat}$	-	0.25	V
	MMUN2241LT1G-MS	$V_{CEsat}$	-	0.25	V

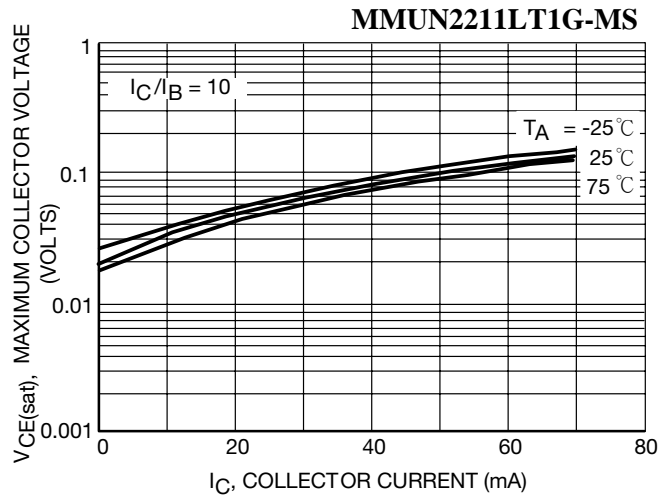
**Characteristics at  $T_a = 25\text{ }^\circ\text{C}$** 

Parameter	Symbol	Min.	Max.	Unit		
Output Voltage (on) at $V_{CC} = 5\text{ V}$ , $V_B = 2.5\text{ V}$ , $R_L = 1\text{ K}\Omega$	MMUN2211LT1G-MS	$V_{OL}$	-	0.2	V	
	MMUN2212LT1G-MS	$V_{OL}$	-	0.2	V	
	MMUN2214LT1G-MS	$V_{OL}$	-	0.2	V	
	MMUN2215LT1G-MS	$V_{OL}$	-	0.2	V	
	MMUN2216LT1G-MS	$V_{OL}$	-	0.2	V	
	MMUN2230LT1G-MS	$V_{OL}$	-	0.2	V	
	MMUN2231LT1G-MS	$V_{OL}$	-	0.2	V	
	MMUN2232LT1G-MS	$V_{OL}$	-	0.2	V	
	MMUN2233LT1G-MS	$V_{OL}$	-	0.2	V	
	MMUN2234LT1G-MS	$V_{OL}$	-	0.2	V	
	MMUN2235LT1G-MS	$V_{OL}$	-	0.2	V	
	MMUN2238LT1G-MS	$V_{OL}$	-	0.2	V	
	at $V_{CC} = 5\text{ V}$ , $V_B = 3.5\text{ V}$ , $R_L = 1\text{ K}\Omega$	MMUN2213LT1G-MS	$V_{OL}$	-	0.2	V
	at $V_{CC} = 5\text{ V}$ , $V_B = 5\text{ V}$ , $R_L = 1\text{ K}\Omega$	MMUN2241LT1G-MS	$V_{OL}$	-	0.2	V
	Output Voltage (off) at $V_{CC} = 5\text{ V}$ , $V_B = 0.5\text{ V}$ , $R_L = 1\text{ K}\Omega$	MMUN2230LT1G-MS	$V_{OH}$	4.9	-	V
at $V_{CC} = 5\text{ V}$ , $V_B = 0.05\text{ V}$ , $R_L = 1\text{ K}\Omega$		MMUN2215LT1G-MS	$V_{OH}$	4.9	-	V
at $V_{CC} = 5\text{ V}$ , $V_B = 0.25\text{ V}$ , $R_L = 1\text{ K}\Omega$		MMUN2216LT1G-MS	$V_{OH}$	4.9	-	V
MMUN2233LT1G-MS		$V_{OH}$	4.9	-	V	
MMUN2238LT1G-MS		$V_{OH}$	4.9	-	V	
Input Resistor		MMUN2211LT1G-MS	R1	7	13	K $\Omega$
	MMUN2212LT1G-MS	R1	15.4	28.6	K $\Omega$	
	MMUN2213LT1G-MS	R1	32.9	61.1	K $\Omega$	
	MMUN2214LT1G-MS	R1	7	13	K $\Omega$	
	MMUN2215LT1G-MS	R1	7	13	K $\Omega$	
	MMUN2216LT1G-MS	R1	3.3	6.1	K $\Omega$	
	MMUN2230LT1G-MS	R1	0.7	1.3	K $\Omega$	
	MMUN2231LT1G-MS	R1	1.5	2.9	K $\Omega$	
	MMUN2232LT1G-MS	R1	3.3	6.1	K $\Omega$	
	MMUN2233LT1G-MS	R1	3.3	6.1	K $\Omega$	
	MMUN2234LT1G-MS	R1	15.4	28.6	K $\Omega$	
	MMUN2235LT1G-MS	R1	1.54	2.86	K $\Omega$	
	MMUN2238LT1G-MS	R1	1.54	2.88	K $\Omega$	
	MMUN2241LT1G-MS	R1	70	130	K $\Omega$	
Resistor Ratio	MMUN2211LT1G-MS /MMUN2212LT1G-MS/MMUN2213LT1G-MS	R1/R2	0.8	1.2	-	
	MMUN2214LT1G-MS	R1/R2	0.17	0.25	-	
	MMUN2215LT1G-MS/MMUN2216LT1G-MS/MMUN2238LT1G-MS	R1/R2	-	-	-	
	MMUN2241LT1G-MS	R1/R2	-	-	-	
	MMUN2230LT1G-MS/MMUN2231LT1G-MS/MMUN2232LT1G-MS	R1/R2	0.8	1.2	-	
	MMUN2233LT1G-MS	R1/R2	0.055	0.185	-	
	MMUN2234LT1G-MS	R1/R2	0.38	0.56	-	
	MMUN2235LT1G-MS	R1/R2	0.038	0.056	-	

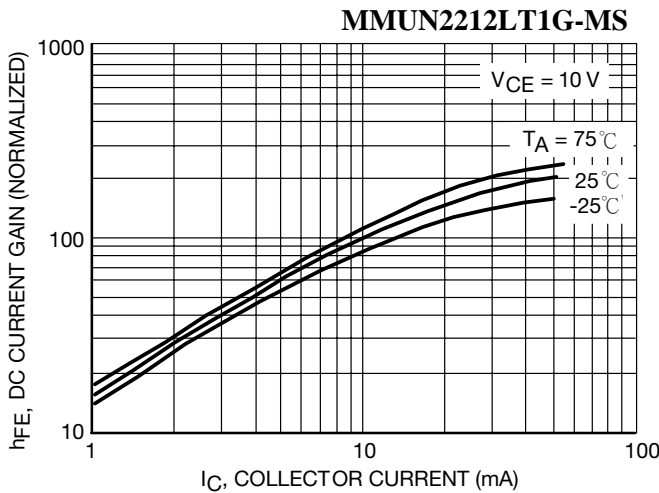
**Typical Characteristics**



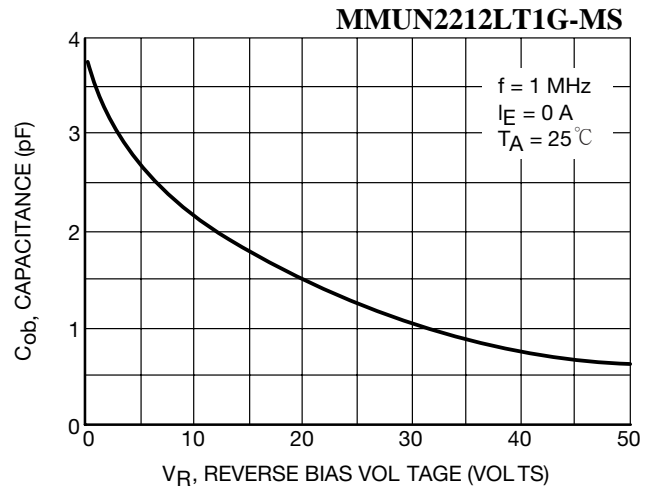
**Figure 1. Derating Curve**



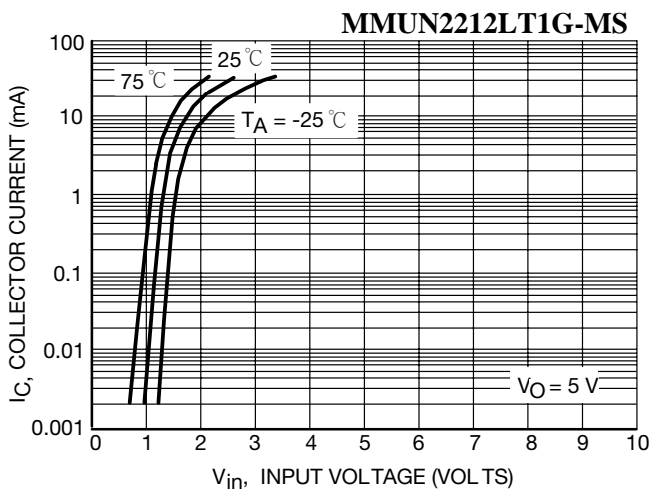
**Figure 2. VCE(sat) vs. IC**



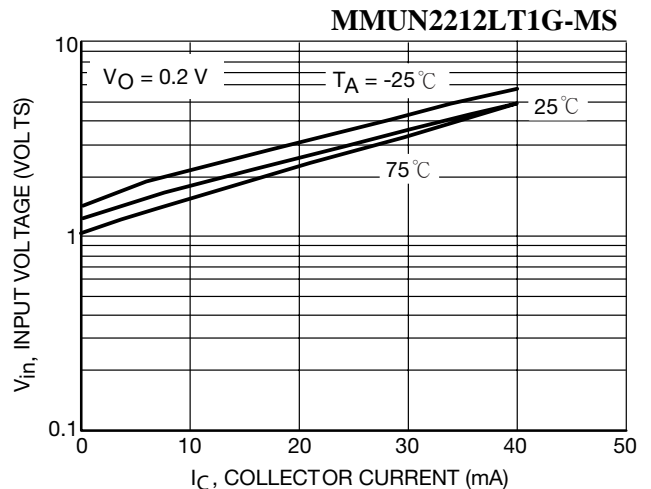
**Figure 3. DC Current Gain**



**Figure 4. Output Capacitance**

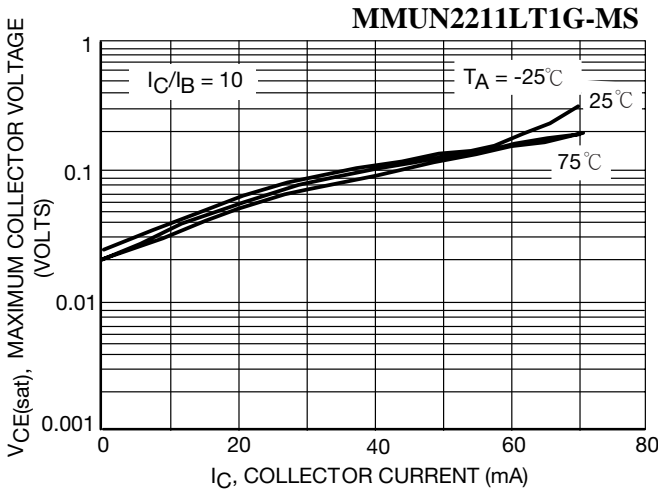


**Figure 5. Output Current vs. Input Voltage**

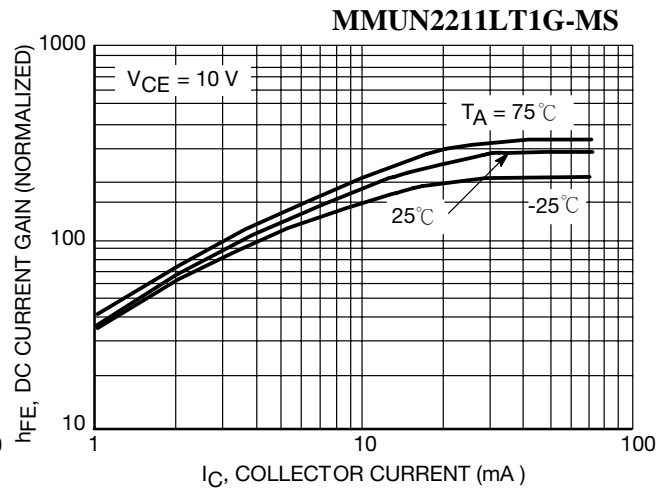


**Figure 6. Input Voltage vs. Output Current**

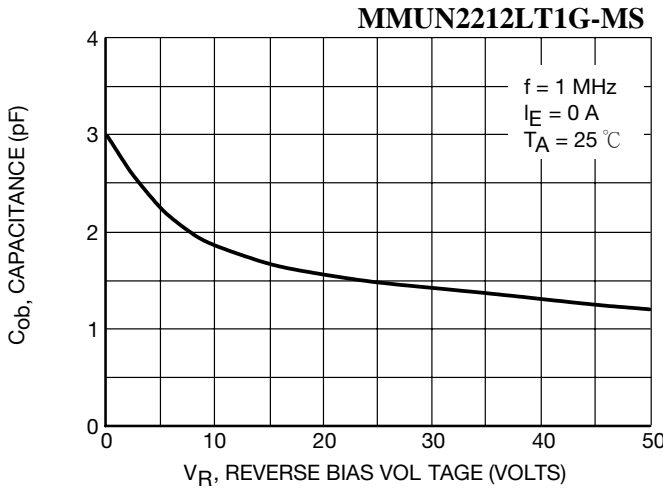
**Typical Characteristics**



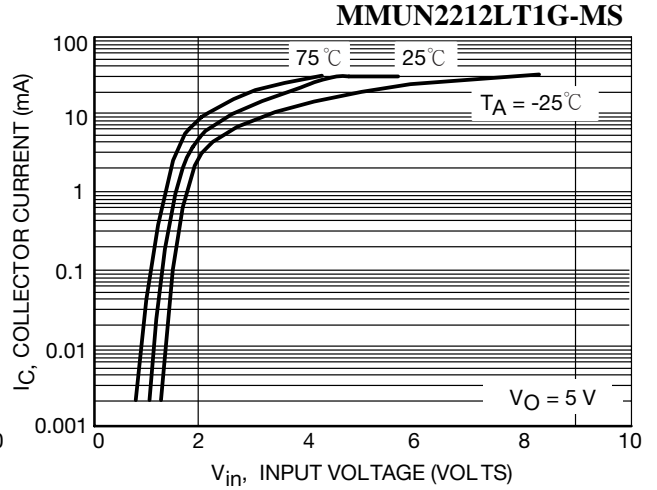
**Figure 7.  $V_{CE(sat)}$  vs.  $I_C$**



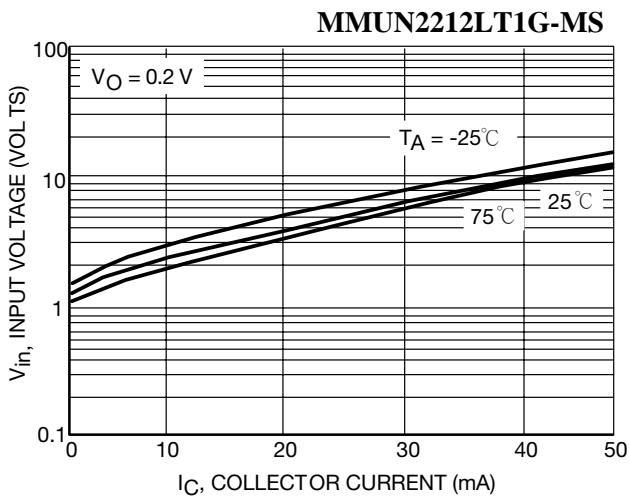
**Figure 8. DC Current Gain**



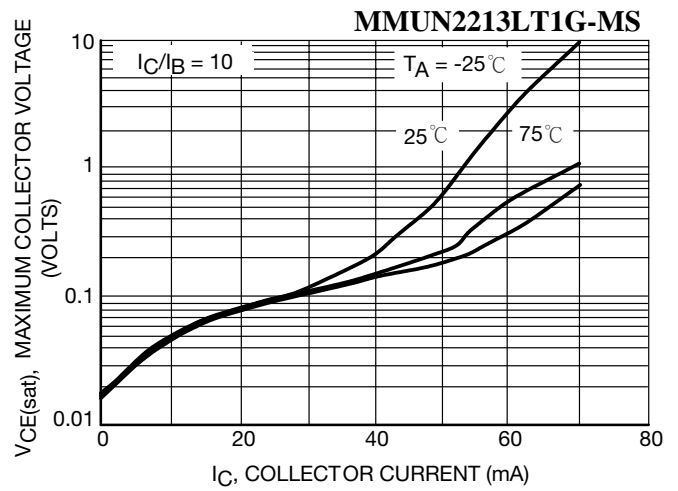
**Figure 9. Output Capacitance**



**Figure 10. Output Current vs. Input Voltage**

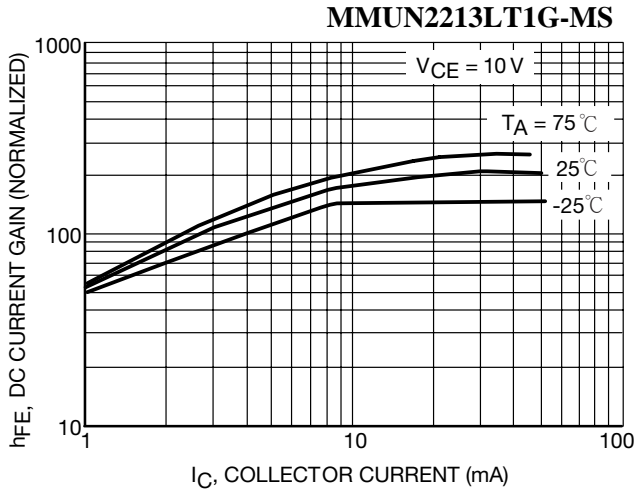


**Figure 11. Input Voltage vs. Output Current**

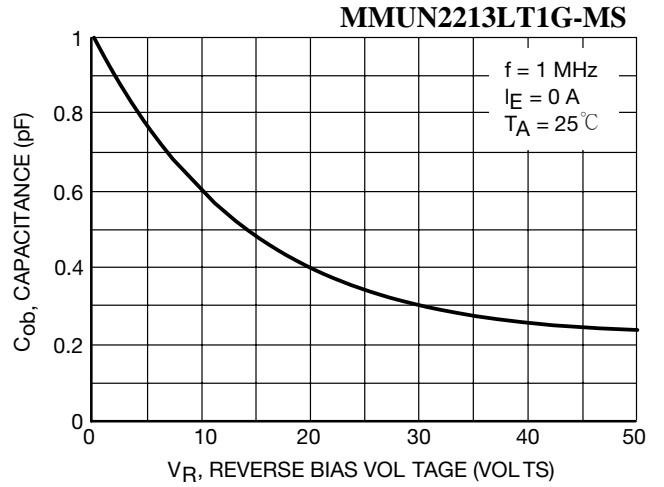


**Figure 12.  $V_{CE(sat)}$  vs.  $I_C$**

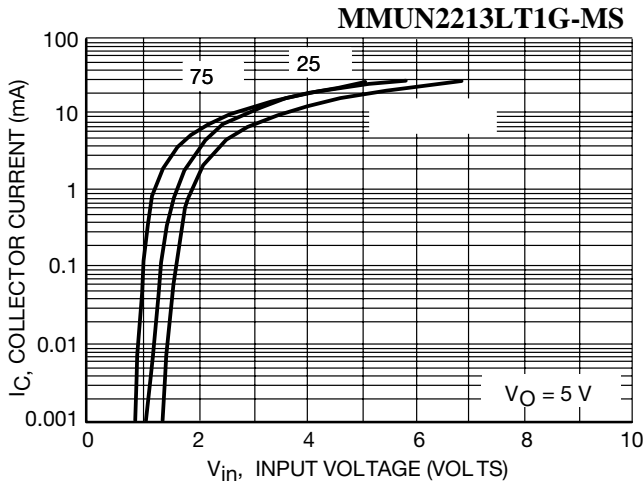
**Typical Characteristics**



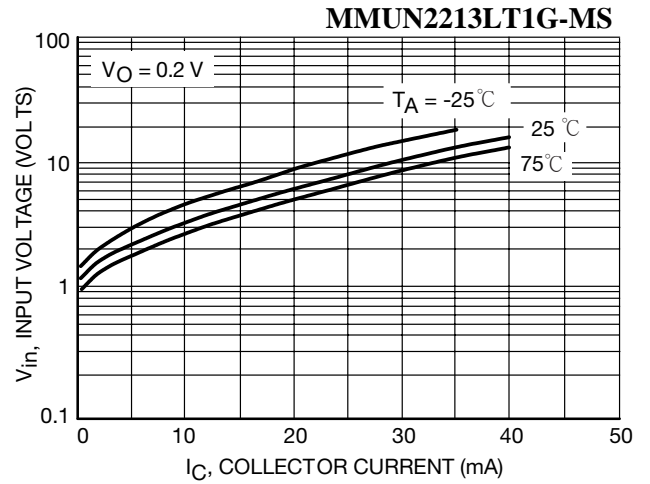
**Figure 13. DC Current Gain**



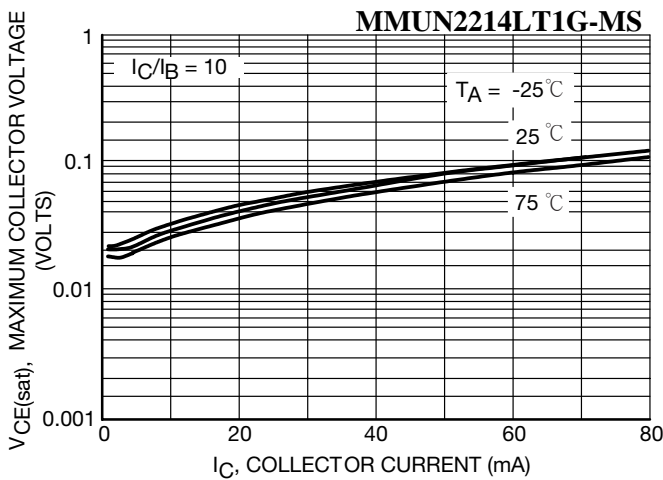
**Figure 14. Output Capacitance**



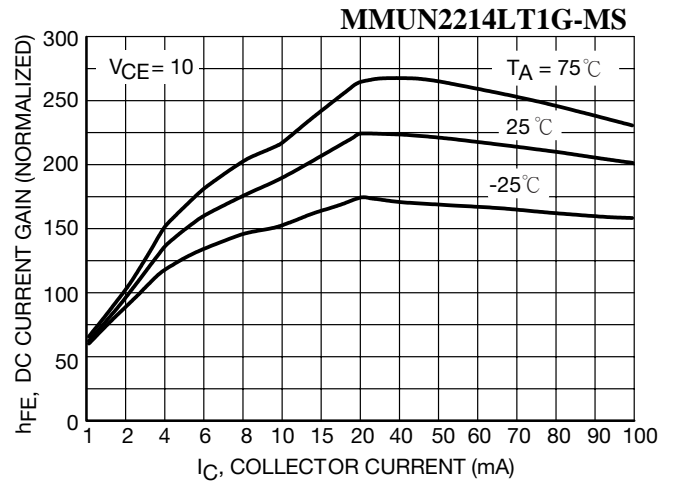
**Figure 15. Output Current vs. Input Voltage**



**Figure 16. Input Voltage vs. Output Current**

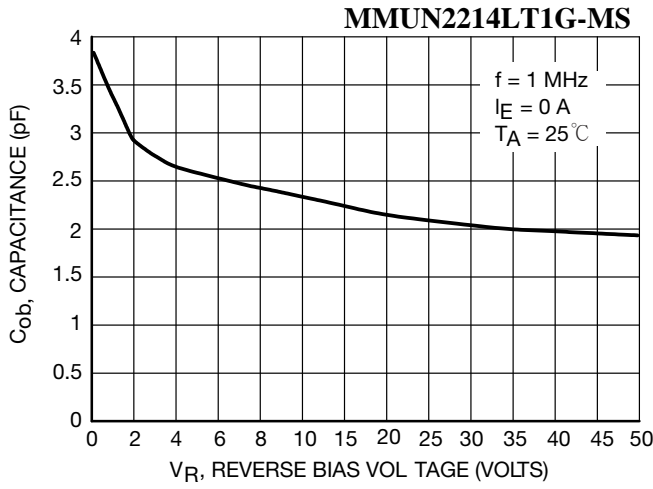


**Figure 17. VCE(sat) vs. IC**

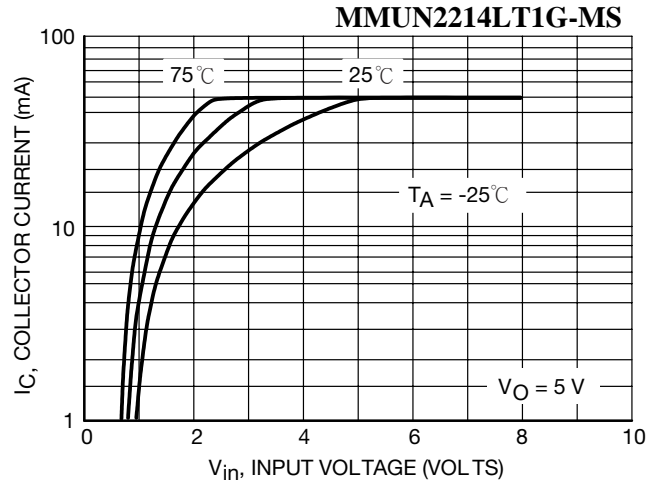


**Figure 18. DC Current Gain**

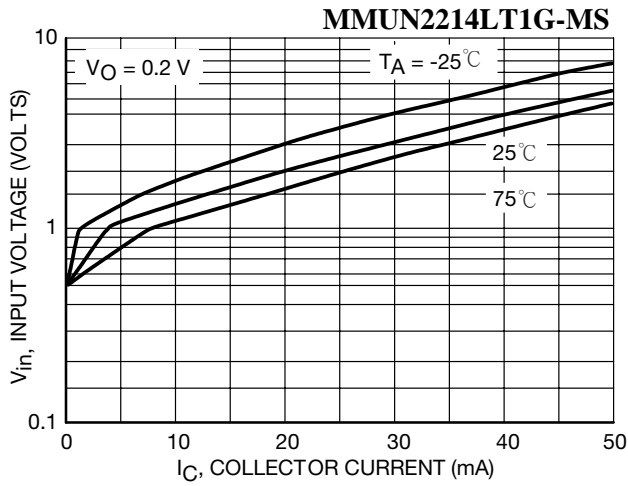
**Typical Characteristics**



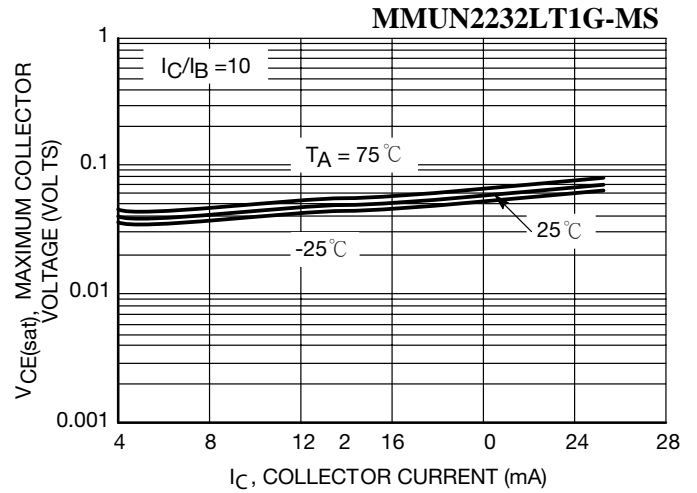
**Figure 19. Output Capacitance**



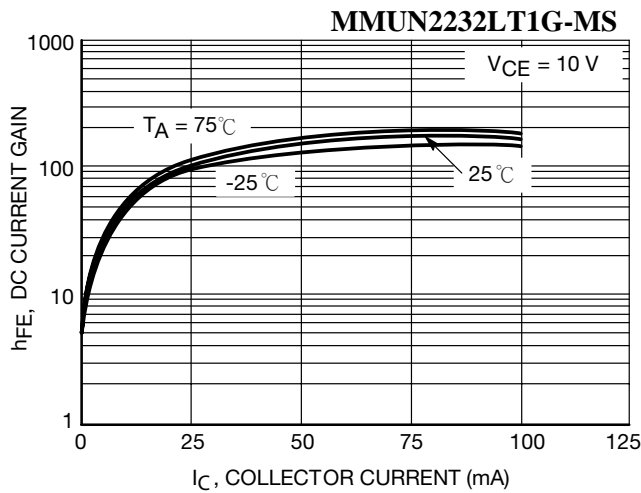
**Figure 20. Output Current vs. Input Voltage**



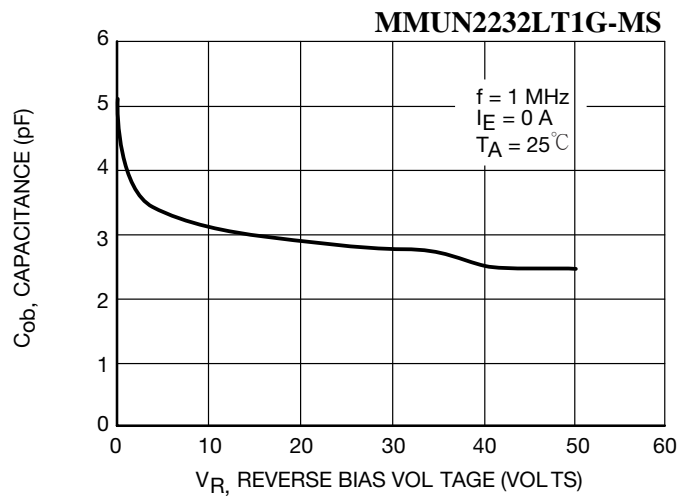
**Figure 21. Input Voltage vs. Output Current**



**Figure 22. VCE(sat) vs. IC**

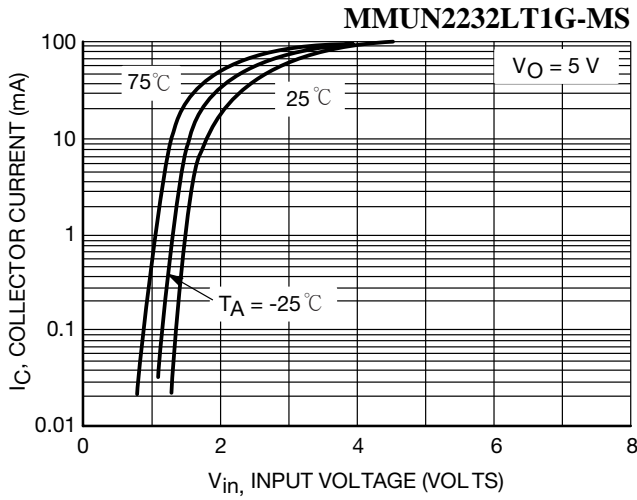


**Figure 23. DC Current Gain**

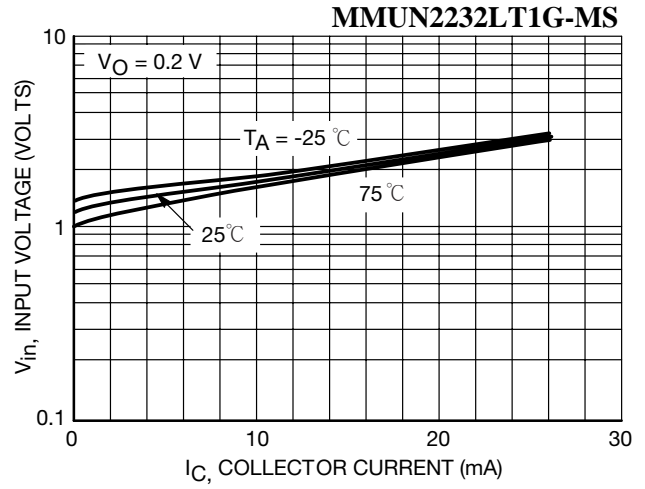


**Figure 24. Output Capacitance**

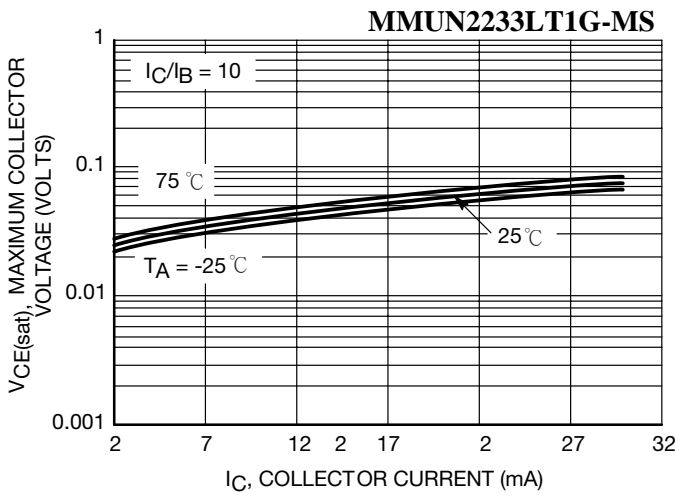
**Typical Characteristics**



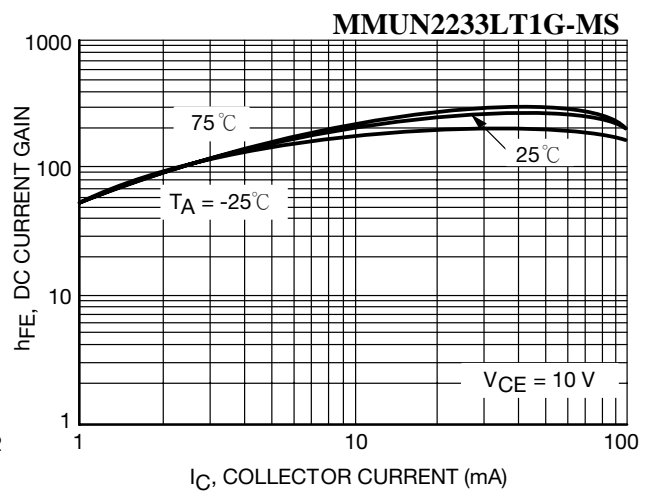
**Figure 25. Output Current vs. Input Voltage**



**Figure 26. Output Voltage vs. Input Current**

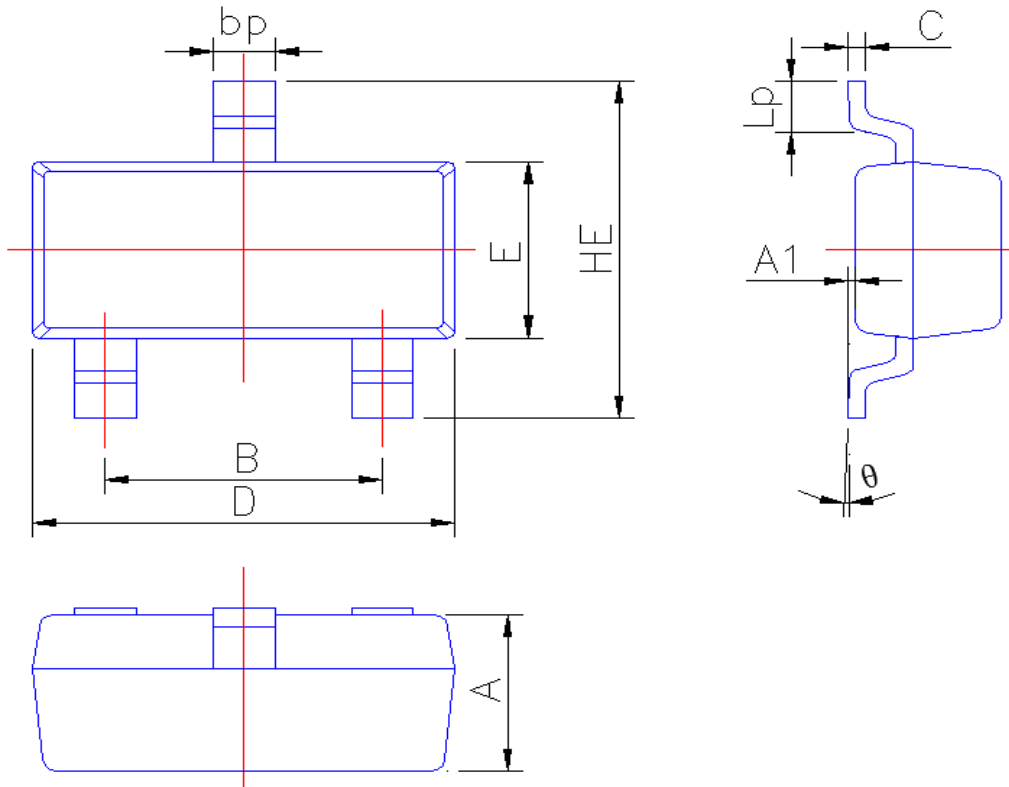


**Figure 27. VCE(sat) vs. IC**



**Figure 28. DC Current Gain**

**PACKAGE MECHANICAL DATA**



SOT-23

Symbol	Dimension in Millimeters	
	Min	Max
A	0.90	1.10
A1	0.013	0.100
B	1.80	2.00
bp	0.35	0.50
C	0.09	0.150
D	2.80	3.00
E	1.20	1.40
HE	2.20	2.80
Lp	0.20	0.50
θ	0°	5°

**REEL SPECIFICATION**

P/N	PKG	QTY
MMUN2211LT1G-MS-MMUN2241LT1G-MS	SOT-23	3000

## Attention

- Any and all MSKSEMI Semiconductor products described or contained herein do not have specifications that can handle applications that require extremely high levels of reliability, such as life-support systems, aircraft's control systems, or other applications whose failure can be reasonably expected to result in serious physical and/or material damage. Consult with your MSKSEMI Semiconductor representative nearest you before using any MSKSEMI Semiconductor products described or contained herein in such applications.
- MSKSEMI Semiconductor assumes no responsibility for equipment failures that result from using products at values that exceed, even momentarily, rated values (such as maximum ratings, operating condition ranges, or other parameters) listed in products specifications of any and all MSKSEMI Semiconductor products described or contained herein.
- Specifications of any and all MSKSEMI Semiconductor products described or contained herein stipulate the performance, characteristics, and functions of the described products in the independent state, and are not guarantees of the performance, characteristics, and functions of the described products as mounted in the customer's products or equipment. To verify symptoms and states that cannot be evaluated in an independent device, the customer should always evaluate and test devices mounted in the customer's products or equipment.
- MSKSEMI Semiconductor strives to supply high-quality high-reliability products. However, any and all semiconductor products fail with some probability. It is possible that these probabilistic failures could give rise to accidents or events that could endanger human lives, that could give rise to smoke or fire, or that could cause damage to other property. When designing equipment, adopt safety measures so that these kinds of accidents or events cannot occur. Such measures include but are not limited to protective circuits and error prevention circuits for safe design, redundant design, and structural design.
- In the event that any or all MSKSEMI Semiconductor products (including technical data, services) described or contained herein are controlled under any of applicable local export control laws and regulations, such products must not be exported without obtaining the export license from the authorities concerned in accordance with the above law.
- No part of this publication may be reproduced or transmitted in any form or by any means, electronic or mechanical, including photocopying and recording, or any information storage or retrieval system, or otherwise, without the prior written permission of MSKSEMI Semiconductor.
- Information (including circuit diagrams and circuit parameters) herein is for example only ; it is not guaranteed for volume production. MSKSEMI Semiconductor believes information herein is accurate and reliable, but no guarantees are made or implied regarding its use or any infringements of intellectual property rights or other rights of third parties.
- Any and all information described or contained herein are subject to change without notice due to product/technology improvement, etc. When designing equipment, refer to the "Delivery Specification" for the MSKSEMI Semiconductor product that you intend to use.