



Description

The MCP6V77T-E/MS family of amplifiers provides input offset voltage correction for very low offset and drift through the use of patented fast step response chopper stabilized techniques. This method constantly measures and compensates the input offset, eliminating drift over time and temperature and the effect of 1/f noise. This design breakthrough allows the combination of a gain bandwidth product of 1.5 MHz and a high slew rate of 1.2 V/ μ s,

while only drawing 125 μ A supply current. These devices are unity gain stable and have good Power Supply Rejection Ratio (PSRR) and Common Mode Rejection Ratio (CMRR).

The MCP6V77T-E/MS series are perfectly suited for applications that require precision amplification of low level signals, in which error sources cannot be tolerated, even in which high bandwidth and fast transition are needed. The rail-to-rail input and output swings make both high-side and low-side sensing easy. The MCP6V77T-E/MS series can operate with a single supply voltage as low as 1.8 V for 2-cell battery applications.

The MCP6V77T-E/MS op-amps have enhanced EMI protection to minimize any electromagnetic interference from external sources, and have high electro-static discharge (ESD) protection (5-kV HBM). All models are specified over the extended industrial temperature range of -40 °C to +125 °C.

Features

- High DC Precision:
 - ± 8 μ V (maximum) VOS with a Drift of ± 40 nV/°C (maximum)
 - A_{VOL} : 112 dB (minimum, $V_{DD} = 5.5V$)
 - PSRR: 112 dB (minimum, $V_{DD} = 5.5V$)
 - CMRR: 112 dB (minimum, $V_{DD} = 5.5V$)
 - V_n : 0.45 μ V_{PP} (typical, $f = 0.1$ to 10 Hz) 1.5 MHz
- Bandwidth and 1.2 V/ μ s Slew Rate Settling
- Time to 0.1% with 1V Step: 1.2 μ s
- Overload Recovery Time to 0.1%: 35 μ s
- Micro-Power 125 μ A per Amplifier and 1.8 V to 5.5 V Wide Supply Voltage
- Range Operating Temperature Range: -40°C to +125°C

Applications

- Precision current sensing
- Resistor thermal detectors
- Temperature, position and pressure sensors
- Medical equipment
- Electronic scales
- Strain gage amplifiers
- Thermocouple amplifiers
- Driving A/D Converters

Ordering Information

Product Model	Package Type	Packing	Packing Qty
MCP6V77T-E/MS	MSOP-8	Tape	3000Pcs/Reel



Pin Configurations (Top View)

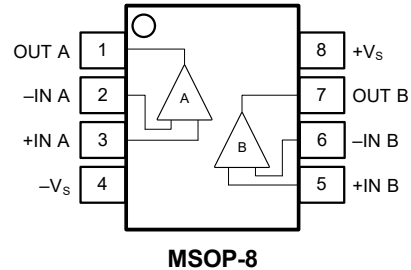
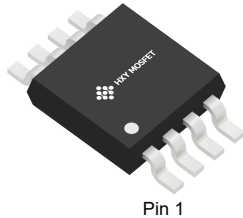

Pin Description

Symbol	Description	Symbol	Description
-IN	Inverting input of the amplifier.	-Vs	Negative (lowest) power supply.
+IN	Non-inverting input of the amplifier.	OUT	Amplifier output.
+Vs	Positive (highest) power supply.	NC	No internal connection.

Limiting Value

In accordance with the Absolute Maximum Rating System (IEC60134).

Parameter	Absolute Maximum Rating
Supply Voltage, V_{S+} to V_{S-}	10.0 V
Signal Input Terminals: Voltage, Current	$V_{S-} - 0.5$ V to $V_{S+} + 0.5$ V, ± 20 mA
Output Short-Circuit	Continuous
Storage Temperature Range, T_{stg}	-65 °C to +150 °C
Junction Temperature, T_J	150 °C
Lead Temperature Range (Soldering 10 sec)	260 °C

ESD Rating

Parameter	Item	Value	Unit
Electrostatic Discharge Voltage	Human body model (HBM), per MIL-STD-883J / Method 30159.	± 5000	V
	Charged device model (CDM), per ESDA/JEDEC JS-002-2014	± 2000	
	Machine model (MM), per JESD22-A115C	± 250	

(1) JEDEC document JEP155 states that 500-V HBM allows safe manufacturing with a standard ESD control process.

(2) JEDEC document JEP157 states that 250-V CDM allows safe manufacturing with a standard ESD control process.



Electrical Characteristics

$V_S = 5.0V$, $T_A = +25^\circ C$, $V_{CM} = V_S/2$, $V_O = V_S/2$, and $R_L = 10k\Omega$ connected to $V_S/2$, unless otherwise noted.

Boldface limits apply over the specified temperature range, $T_A = -40$ to $+125^\circ C$.

Symbol	Parameter	Conditions	Min.	Typ.	Max.	Unit
OFFSET VOLTAGE						
V_{OS}	Input offset voltage			± 2	± 8	μV
$V_{OS\ TC}$	Offset voltage drift	$T_A = -40$ to $+125^\circ C$		± 5	± 40	$nV/^\circ C$
PSRR	Power supply rejection ratio	$V_S = 2.0$ to $5.5\ V$, $V_{CM} < V_{S+} - 2V$	112	126		dB
		$T_A = -40$ to $+125^\circ C$	106			
INPUT BIAS CURRENT						
I_B	Input bias current			± 70		pA
		$T_A = +85^\circ C$		± 150		
		$T_A = +125^\circ C$		± 700		
I_{OS}	Input offset current			± 100		pA
NOISE						
V_n	Input voltage noise	$f = 0.01$ to $1\ Hz$		0.1		μV_{P-P}
		$f = 0.1$ to $10\ Hz$		0.45		
e_n	Input voltage noise density	$f = 10\ kHz$		15		nV/\sqrt{Hz}
		$f = 1\ kHz$		19		
I_n	Input current noise density	$f = 1\ kHz$		10		fA/\sqrt{Hz}
INPUT VOLTAGE						
V_{CM}	Common-mode voltage range		$V_{S-} - 0.1$		$V_{S+} + 0.1$	V
CMRR	Common-mode rejection ratio	$V_S = 5.5\ V$, $V_{CM} = -0.1$ to $5.5\ V$	112	130		dB
		$V_{CM} = 0$ to $5.3\ V$, $T_A = -40$ to $+125^\circ C$	106			
		$V_S = 2.0\ V$, $V_{CM} = -0.1$ to $2.0\ V$	102	122		
		$V_{CM} = 0$ to $1.8\ V$, $T_A = -40$ to $+125^\circ C$	96			
INPUT IMPEDANCE						
R_{IN}	Input resistance		100			$G\Omega$
C_{IN}	Input capacitance	Differential		2.0		pF
		Common mode		3.5		
OPEN-LOOP GAIN						
A_{VOL}	Open-loop voltage gain	$R_L = 20\ k\Omega$, $V_O = 0.05$ to $3.5\ V$	112	132		dB
		$T_A = -40$ to $+125^\circ C$	106			
		$R_L = 2\ k\Omega$, $V_O = 0.15$ to $3.5\ V$	101	120		
		$T_A = -40$ to $+125^\circ C$	95			



FREQUENCY RESPONSE						
GBW	Gain bandwidth product	$f = 1 \text{ kHz}$		1.5		MHz
SR	Slew rate	$G = +1, C_L = 100 \text{ pF}, V_O = 1.5 \text{ to } 3.5 \text{ V}$		1.2		V/ μs
t_s	Settling time	To 0.1%, $G = +1, 1\text{V step}$		1.2		μs
		To 0.01%, $G = +1, 1\text{V step}$		1.5		
t_{OR}	Overload recovery time	To 0.1%, $V_{IN} * \text{Gain} > V_S$		35		μs

Electrical Characteristics (continued)

$V_S = 5.0\text{V}, T_A = +25^\circ\text{C}, V_{CM} = V_S/2, V_O = V_S/2,$ and $R_L = 10\text{k}\Omega$ connected to $V_S/2$, unless otherwise noted. Boldface limits apply over the specified temperature range, $T_A = -40$ to $+125^\circ\text{C}$.

Symbol	Parameter	Conditions	Min.	Typ.	Max.	Unit
OUTPUT						
V_{OH}	High output voltage swing	$R_L = 20 \text{ k}\Omega$		$V_{S+}-6$		mV
		$R_L = 2 \text{ k}\Omega$	$V_{S+}-100$	$V_{S+}-60$		
V_{OL}	Low output voltage swing	$R_L = 20 \text{ k}\Omega$		$V_{S-}+4$		mV
		$R_L = 2 \text{ k}\Omega$		$V_{S-}+40$	$V_{S-}+66$	
Z_{OUT}	Open-loop output impedance	$f = 350 \text{ kHz}, I_o = 0$		2		k Ω
I_{SC}	Short-circuit current	Source current through 10Ω		40		mA
		Sink current through 10Ω		50		
POWER SUPPLY						
V_S	Operating supply voltage	$T_A = 0 \text{ to } +70 \text{ }^\circ\text{C}$	1.8		5.5	V
		$T_A = -40 \text{ to } +125 \text{ }^\circ\text{C}$	2.0		5.5	
I_Q	Quiescent current (per amplifier)		80	125	190	μA
THERMAL CHARACTERISTICS						
T_A	Operating temperature range		-40		+125	$^\circ\text{C}$
θ_{JA}	Package Thermal Resistance			125		$^\circ\text{C/W}$



Typical Performance Characteristics

At $T_A=+25^{\circ}\text{C}$, $V_S=\pm 2.5\text{V}$, $V_{CM}=V_S/2$, $R_L=10\text{k}\Omega$ connected to $V_S/2$, and $C_L=100\text{pF}$, unless otherwise noted.

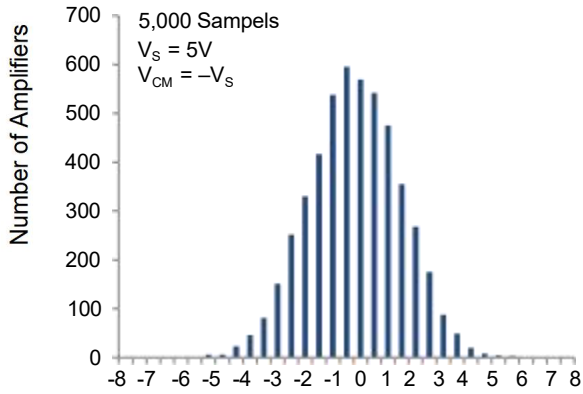

Input Offset Voltage Production Distribution.

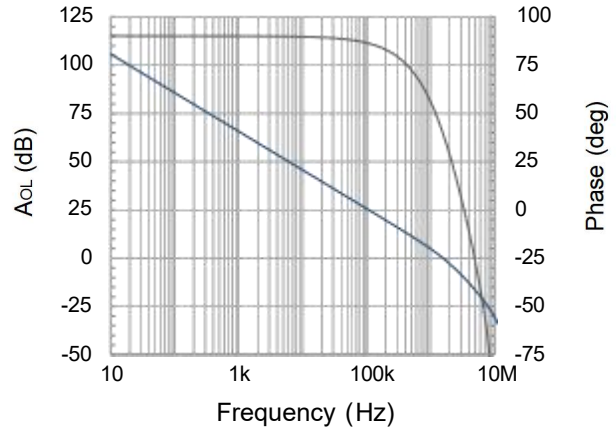

Open-loop Gain and Phase as a function of Frequency.

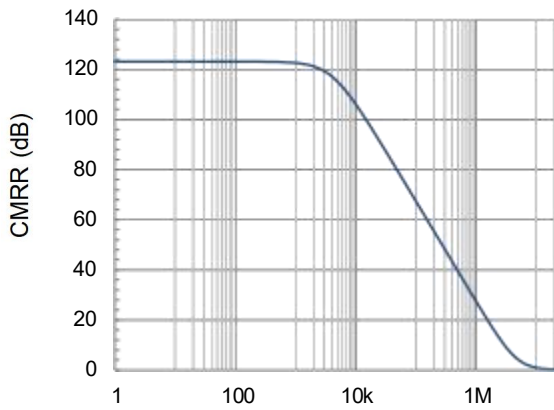

Common-mode Rejection Ratio as a function of Frequency.

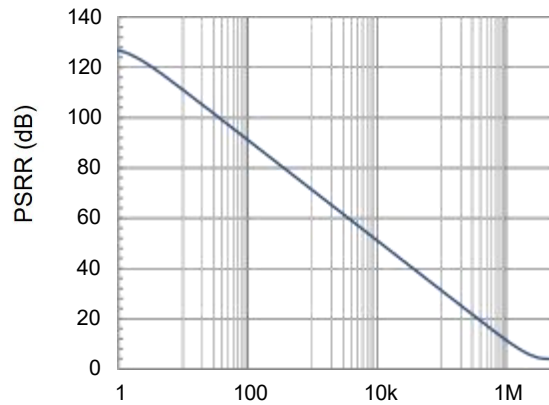

Power Supply Rejection Ratio as a function of Frequency.

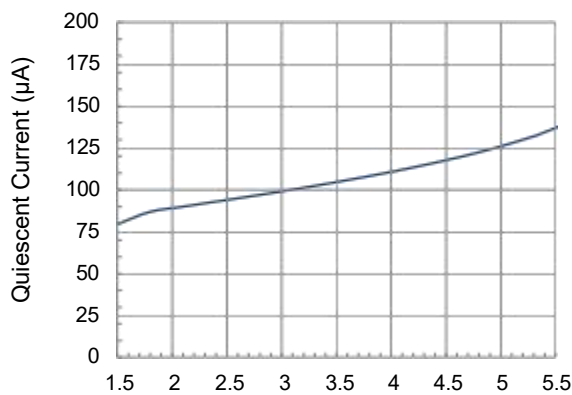

Quiescent Current as a function of Supply Voltage.

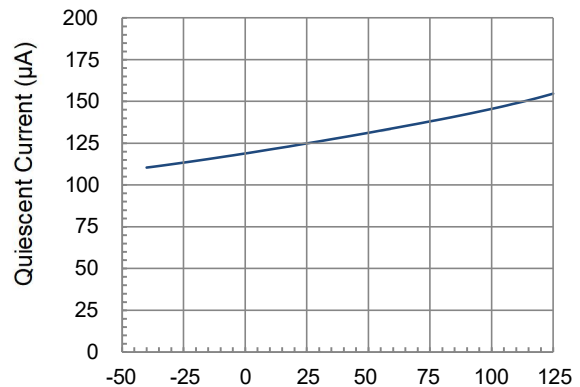

Quiescent Current as a function of Temperature.



Typical Performance Characteristics (continued)

At $T_A = +25^\circ\text{C}$, $V_{CM} = V_S/2$, and $R_L = 10\text{k}\Omega$ connected to $V_S/2$, unless otherwise noted.

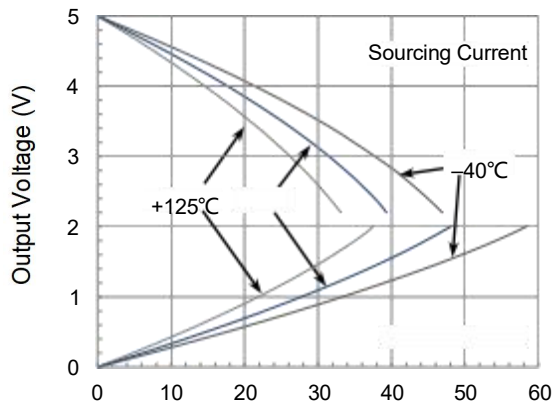

Output Voltage Swing as a function of Output Current.

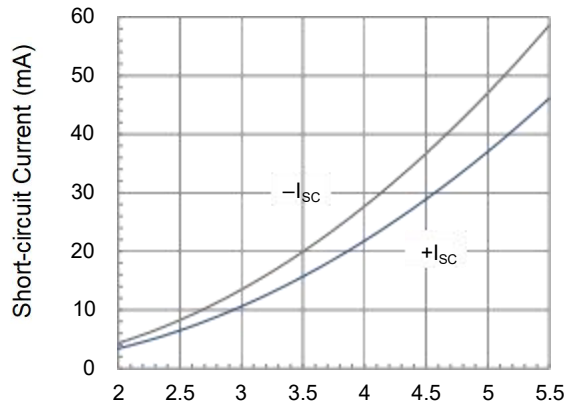

Short-circuit Current as a function of Supply Voltage.

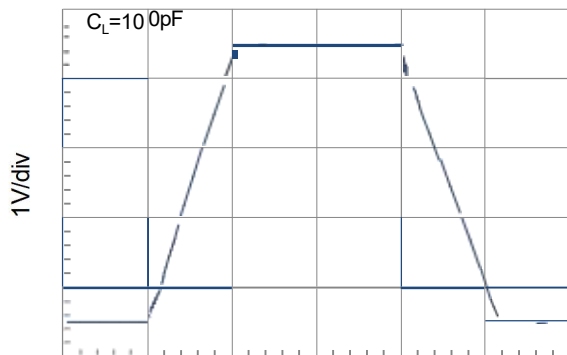

2.5 $\mu\text{s}/\text{div}$
Large Signal Step Response (4V Step).

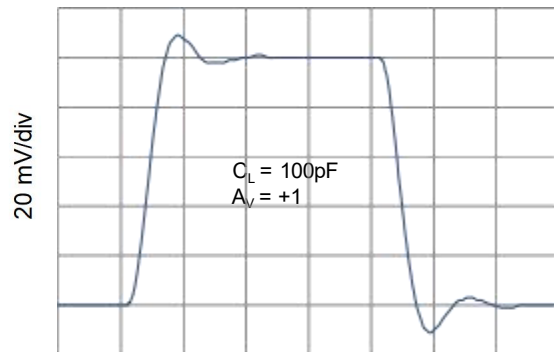

0.25 $\mu\text{s}/\text{div}$
Small Signal Step Response (100mV Step).



Application Notes

The MCP6V77T-E/MS operational amplifiers are unity-gain stable and free from unexpected output phase reversal. These devices use a proprietary auto-calibration technique to provide low offset voltage and very low drift over time and temperature. For lowest offset voltage and precision performance, optimize circuit layout and mechanical conditions. Avoid temperature gradients that create thermoelectric (Seebeck) effects create in the thermocouple junctions formed from connecting dissimilar conductors. Cancel these thermally-generated potentials by assuring they are equal on both input terminals. Other layout and design considerations include:

- Use low thermoelectric-coefficient conditions (avoid dissimilar metals).
- Thermally isolate components from power supplies or other heat sources.
- Shield operational amplifier and input circuitry from air currents, such as cooling fans.

Following these guidelines reduces the likelihood of junctions being at different temperatures, which can cause thermoelectric voltages of $0.1\mu\text{V}/^\circ\text{C}$ or higher, depending on materials used.

OPERATING VOLTAGE

The MCP6V77T-E/MS family is fully specified and ensured for operation from 2.0v to 5.5v ($\pm 1.0\text{v}$ to $\pm 2.75\text{v}$). In addition, many specifications apply from -40°C to $+125^\circ\text{C}$. Parameters that Vary significantly With operating voltages or temperature are illustrated in the Typical Characteristics graphs.

NOTE: Supply voltages (V_{S+} to V_{S-}) higher than +10v can permanently damage the device.

INPUT VOLTAGE

The input common-mode voltage range of the MCP6V77T-E/MS series extends 100mV beyond the negative supply rail and reaches the positive supply rail. This performance is achieved with a complementary input stage: an N-channel input differential pair in parallel with a P-channel differential pair. The N-channel pair is active for input voltages close to the positive rail, typically $V_{S+}-1.4\text{V}$ to the positive supply, whereas the P-channel pair is active for inputs from 200mV below the negative supply to approximately $V_{S-}-1.4\text{V}$. There is a small transition region, typically $V_{S-}-1.2\text{V}$ to $V_{S+}-1\text{V}$, in which both pairs are on. This 200mV transition region can vary up to 200mV with process variation. Thus, the transition region (both stages on) can range from $V_{S+}-1.4\text{V}$ to $V_{S-}-1.2\text{V}$ on the low end, up to $V_{S+}-1\text{V}$ to $V_{S-}-0.8\text{V}$ on the high end. Within this transition region, PSRR, CMRR, offset voltage, offset drift, and THD can be degraded compared to device operation outside this region.

The typical input bias current of the MCP6V77T-E/MS during normal operation is approximately 70pA. In over-driven conditions, the bias current can increase significantly. The most common cause of an over driven condition occurs when the operational amplifier is outside of the linear range of operation. When the output of the operational amplifier is driven to one of the supply rails, the feedback loop requirements cannot be satisfied and a differential input voltage develops across the input pins. This differential input voltage results in activation of parasitic diodes inside the front-end input. The typical input bias current of the MCP6V77T-E/MS during chopping switches that combine with electromagnetic interference (EMI) filter resistors to create the equivalent circuit. Notice that the input bias current remains within specification in the linear region.

INPUT EMI FILTER AND CLAMP CIRCUIT

Figure 1 shows the input EMI filter and clamp circuit. The MCP6V77T-E/MS op-amps have internal ESD protection diodes (D1, D2, D3, and D4) that are connected between the inputs and each supply rail. These diodes protect the input transistors in the event of electrostatic discharge and are reverse biased during normal operation. This protection scheme allows voltages as high as approximately 500mV beyond the rails to be applied at the input of either terminal without causing permanent damage. See the table of Absolute Maximum Ratings for more information.

Operational amplifiers vary in susceptibility to EMI. If conducted EMI enters the operational amplifier, the dc offset at the amplifier output can shift from its nominal value when EMI is present. This shift is a result of signal rectification associated with the internal semiconductor junctions. Although all operational amplifier pin functions can be affected by EMI, the input pins are likely to be the most susceptible. The EMI filter of the MCP6V77T-E/MS family is composed of two 5-k Ω input series resistors (R_{S1} and R_{S2}), two common-mode capacitors (C_{CM1} and C_{CM2}), and a differential capacitor (C_{DM}). These RC networks set the -3dB low-pass cutoff frequencies at 35-MHz for common-mode signals, and at 22-MHz for differential signals.

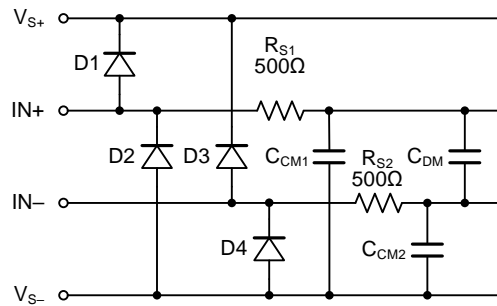

Figure1.Input EMI Filterand Clamp Circuit

INTERNAL OFFSET CORRECTION

The MCP6V77T-E/MS operational amplifiers use an auto-calibration technique with a time-continuous 500kHz operational amplifier in the signal path. This amplifier is zero-corrected every 2 μ s using a proprietary technique. Upon power up, the amplifier requires approximately 100 μ s to achieve specified VOS accuracy. This design has no aliasing or flicker noise.

CAPACITIVE LOAD AND STABILITY

The MCP6V77T-E/MS family can safely drive capacitive loads of up to 500pF in any configuration. As with most amplifiers, driving larger capacitive loads than specified may cause excessive overshoot and ringing ,or even oscillation. A heavy capacitive load reduces the phase margin and causes the amplifier frequency response to peak. Peaking corresponds to overshooting or ringing in the time domain. Therefore, it is recommended that external compensation be used if the MCP6V77T-E/MS op-amps must drive a load exceeding 500pF. This compensation is particularly important in the unity-gain configuration, which is the worst case for stability.

A quick and easy way to stabilize the op-amp for capacitive load drive is by adding a series resistor, R_{ISO} , between the amplifier output terminal and the load capacitance, as shown in Figure 2. R_{ISO} isolates the amplifier output and feedback network from the capacitive load. The bigger the R_{ISO} resistor value, the more stable V_{OUT} will be. Note that this method results in a loss of gain accuracy because R_{ISO} forms a voltage divider with the R_L .

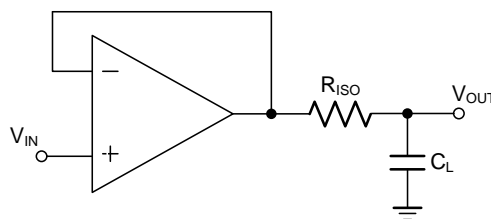

Figure 2. Indirectly Driving Heavy Capacitive Load

An improvement circuit is shown in Figure 3. It provides DC accuracy as well as AC stability. The R_F provides the DC accuracy by connecting the inverting signal with the output.

The C_F and R_{ISO} serve to counteract the loss of phase margin by feeding the high frequency component of the output signal back to the amplifier's inverting input, thereby preserving phase margin in the overall feedback loop. parallel with the feedback resistor to counteract the parasitic capacitance associated with inverting node For no-buffer configuration, there are two others ways to increase the phase margin: (a) by increasing the amplifier's gain, or (b) by placing a capacitor in parallel with the feedback resistor to counteract the parasitic capacitance associated with inverting node.

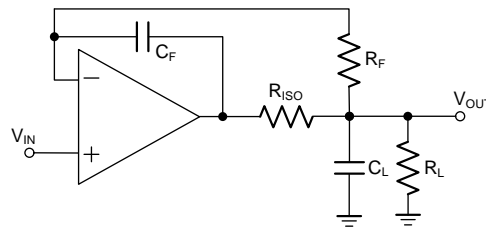

Figure 3. Indirectly Driving Heavy Capacitive Load with DC Accuracy

OVERLOAD RECOVERY

Overload recovery is defined as the time required for the operational amplifier output to recover from a saturated state to a linear state. The output devices of the operational amplifier enter a saturation region when the output voltage exceeds the rated operating voltage, either because of the high input voltage or the high gain. After the device enters the saturation region, the charge carriers in the output devices require time to return back to the linear state. After the charge carriers return back to the linear state, the device begins to slew at the specified slew rate. Thus, the propagation delay in case of an overload condition is the sum of the overload recovery time and the slew time. The overload recovery time for the MCP6V77T-E/MS family is approximately 35 μ s.

EMI REJECTION RATIO

Circuit performance is often adversely affected by high frequency EMI. When the signal strength is low and transmission lines are long, an op-amp must accurately amplify the input signals. However, all op-amp pins — the non-inverting input, inverting input, positive supply, negative supply, and output pins — are susceptible to EMI signals. These high frequency signals are coupled into an op-amp by various means, such as conduction, near field radiation, or far field radiation. For example, wires and printed circuit board (PCB) traces can act as antennas and pick up high frequency EMI signals.

Amplifiers do not amplify EMI or RF signals due to their relatively low bandwidth. However, due to the nonlinearities of the input devices, op-amps can rectify these out of band signals. When these high frequency signals are rectified, they appear as a dc offset at the output.

The MCP6V77T-E/MS op-amps have integrated EMI filters at their input stage. A mathematical method of measuring EMIRR is defined as follows:

$$EMIRR = 20 \log (V_{IN_PEAK} / \Delta V_{OS})$$

MAXIMIZING PERFORMANCE THROUGH PROPER LAYOUT

To achieve the maximum performance of the extremely high input impedance and low offset voltage of the MCP6V77T-E/MS op-amps, care is needed in laying out the circuit board. The PCB surface must remain clean and free of moisture to avoid leakage currents between adjacent traces. Surface coating of the circuit board reduces surface moisture and provides a humidity barrier, reducing parasitic resistance on the board. The use of guard rings around the amplifier inputs further reduces leakage currents. Figure 4 shows proper guard ring configuration and the top view of a surface-mount layout. The guard ring does not need to be a specific width, but it should form a continuous loop around both inputs. By setting the guard ring voltage equal to the voltage at the non-inverting input, parasitic capacitance is minimized as well. For further reduction of leakage currents, components can be mounted to the PCB using Teflon standoff insulators.

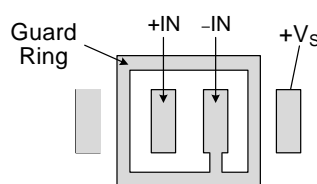

Figure4. Use a guard ring around sensitive pins



Other potential sources of offset error are thermoelectric voltages on the circuit board. This voltage, also called Seebeck voltage, occurs at the junction of two dissimilar metals and is proportional to the temperature of the junction. The most common metallic junctions on a circuit board are solder-to-board trace and solder-to-component lead. If the temperature of the PCB at one end of the component is different from the temperature at the other end, the resulting Seebeck voltages are not equal, resulting in a thermal voltage error.

This thermocouple error can be reduced by using dummy components to match the thermoelectric error source. Placing the dummy component as close as possible to its partner ensures both Seebeck voltages are equal, thus canceling the thermocouple error. Maintaining a constant ambient temperature on the circuit board further reduces this error. The use of a ground plane helps distribute heat throughout the board and reduces EMI noise pickup.

INPUT-TO-OUTPUT COUPLING

To minimize capacitive coupling, the input and output signal traces should not be parallel. This helps reduce unwanted positive feedback.



Typical Application Circuits

PRECISION LOW-SIDE CURRENTSHUNT SENSING

Many applications require the sensing of signals near the positive or negative rails. Current shunt sensing is one such application and is mostly used for feedback control systems. It is also used in a variety of other applications, including power metering, battery fuel gauging, and feedback controls in industrial applications. In such applications, it is desirable to use a shunt with very low resistance to minimize series voltage drop. This configuration not only minimizes wasted power, but also allows the measurement of high currents while saving power.

A typical shunt may be $100\text{m}\Omega$. At a measured current of 1A, the voltage produced from the shunt is 100mV, and the amplifier error sources are not critical. However, at low measured current in the 1mA range, the $100\mu\text{V}$ generated across the shunt demands a very low offset voltage and drift amplifier to maintain absolute accuracy. The unique attributes of a zero drift amplifier provide a solution. Figure 5 shows a low-side current sensing circuit using the MCP6V77T-E/MS. The MCP6V77T-E/MS are configured as difference amplifiers with a gain of 1000.

Although the MCP6V77T-E/MS have high CMRR, the CMRR of the system is limited by the external resistors. Therefore, the key to high CMRR for the system is resistors that are well matched from both the resistive ratio and relative drift, where $R_1/R_2 = R_3/R_4$. The transfer function is given by:

$$V_{\text{OUT}} = V_{\text{SHUNT}} \times \text{Gain}_{\text{Diff_Amp}} = (R_{\text{SHUNT}} \times I_{\text{LOAD}}) \times (R_2 / R_1) = 100 \times I_{\text{LOAD}}$$

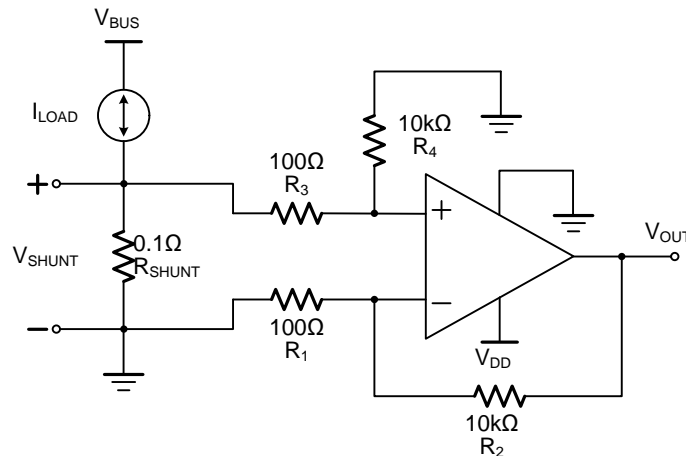

Figure5.Low-Side Current Sensing Circuit

Any unused channel of the MCP6V77T-E/MS must be configured in unity gain with the input common-mode voltage tied to the midpoint of the power supplies.

BIDIRECTIONALCURRENT-SENSING

This single-supply, low-side, bidirectional current-sensing solution detects load currents from -1A to $+1\text{A}$. The single-ended output spans from 110mV to 3.19V. This design uses the MCP6V77T-E/MS because of its low offset voltage and rail-to-rail input and output. One of the amplifiers is configured as a difference amplifier and the other amplifier provides the reference voltage. Figure 6 shows the solution. This solution has the following requirements:

- Supply voltage: 3.3V
- Input: -1A to $+1\text{A}$
- Output: $1.65\text{V} \pm 1.54\text{V}$ (110mV to 3.19V)

There are two types of errors in this design: offset and gain. Gain errors are introduced by the tolerance of the shunt resistor and the ratios of R_4 to R_3 and, similarly, R_2 to R_1 . Offset errors are introduced by the voltage divider (R_5 and R_6) and how closely the ratio of R_4/R_3 matches R_2/R_1 . The latter value affects the CMRR of the difference amplifier, ultimately translating to an offset error.



Typical Application Circuits

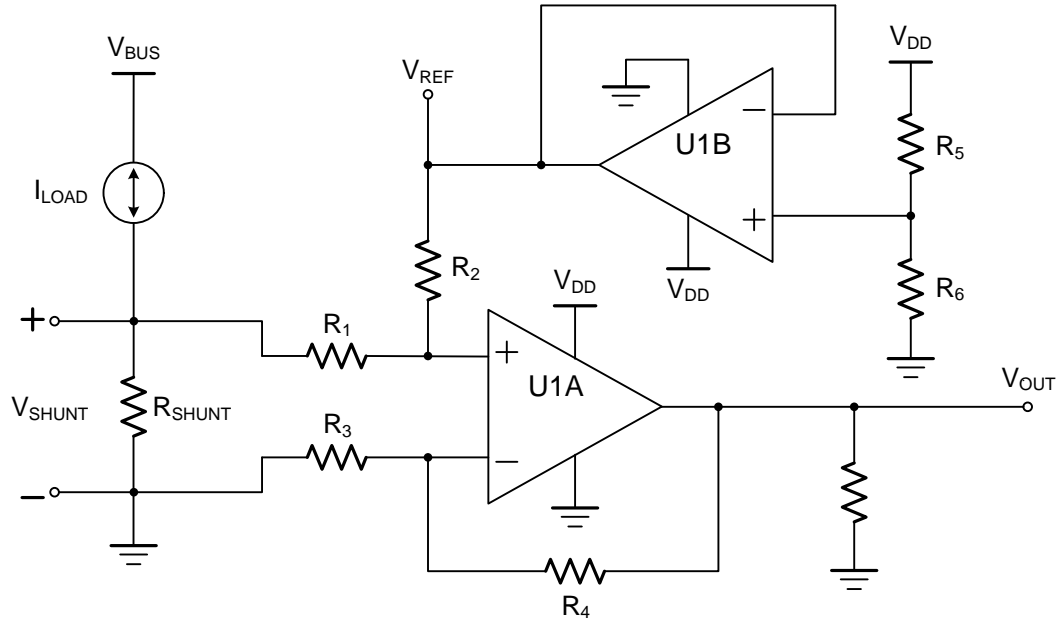

Figure6. Bidirectional Current-Sensing Schematic

The load current, I_{LOAD} , flows through the shunt resistor (R_{SHUNT}) to develop the shunt voltage, V_{SHUNT} . The shunt voltage is then amplified by the difference amplifier consisting of U1A and R_1 through R_4 . The gain of the difference amplifier is set by the ratio of R_4 to R_3 . To minimize errors, set $R_2=R_4$ and $R_1=R_3$. The reference voltage, V_{REF} , is supplied by buffering a resistor divider using U1B. The transfer function is given by Equation 1.

Equation 1:

$$V_{OUT} = V_{SHUNT} \times \text{Gain}_{\text{Diff_Amp}} + V_{REF}$$

Where

- $V_{SHUNT} = I_{LOAD} \times R_{SHUNT}$
- $\text{Gain}_{\text{Diff_Amp}} = R_4 / R_3$
- $V_{REF} = V_{DD} \times [R_6 / (R_5 + R_6)]$

There are two types of errors in this design: offset and gain. Gain errors are introduced by the tolerance of the shunt resistor and the ratios of R_4 to R_3 and, similarly, R_2 to R_1 . Offset errors are introduced by the voltage divider (R_5 and R_6) and how closely the ratio of R_4/R_3 matches R_2/R_1 . The latter value affects the CMRR of the difference amplifier, ultimately translating to an offset error.

The value of V_{SHUNT} is the ground potential for the system load because V_{SHUNT} is a low-side measurement.

Therefore, a maximum value must be placed on V_{SHUNT} . In this design, the maximum value for V_{SHUNT} is set to 100mV. Equation 2 calculates the maximum value of the shunt resistor given a maximum shunt voltage of 100mV and maximum load current of 1A.

$$\text{Equation 2 : } R_{SHUNT(MAX)} = V_{SHUNT(MAX)} / I_{LOAD(MAX)} = 100\text{mV} / 1\text{A} = 100 \text{ m}\Omega$$

The tolerance of R_{SHUNT} is directly proportional to cost. For this design, a shunt resistor with a tolerance of 0.5% was selected. If greater accuracy is required, select a 0.1% resistor or better.

The load current is bidirectional; therefore, the shunt voltage range is -100mV to $+100\text{mV}$. This voltage is divided down by R_1 and R_2 before reaching the operational amplifier, U1A. Take care to ensure that the voltage present at the non-inverting node of U1A is within the common-mode range of the device. Therefore, use an operational amplifier, such as the MCP6V77T-E/MS, that has a common-mode range that extends below the negative supply voltage. Finally, to minimize offset error, note that the MCP6V77T-E/MS has a typical offset voltage of merely $\pm 2\mu\text{V}$ ($\pm 8\mu\text{V}$ maximum).

Given a symmetric load current of -1A to $+1\text{A}$, the voltage divider resistors (R_5 and R_6) must be equal. To be consistent with the shunt resistor, a tolerance of 0.5% was selected. To minimize power consumption, 10k Ω resistors were used.



Typical Application Circuits

To set the gain of the difference amplifier, the common-mode range and output swing of the MCP6V77T-E/MS must be considered. Equation 3 and Equation 4 depict the typical common-mode range and maximum output swing, respectively, of the MCP6V77T-E/MS given a 3.3V supply.

Equation 3: $-100\text{mV} < \text{VCM} < 3.4\text{V}$ **Equation 4:** $100\text{mV} < \text{VOUT} < 3.2\text{V}$

The gain of the difference amplifier can now be calculated as shown in Equation 5.

Equation 5: $\text{Gain}_{\text{Diff_Amp}} = (\text{V}_{\text{OUT_MAX}} - \text{V}_{\text{OUT_MIN}}) / [R_{\text{SHUNT}} \times (I_{\text{MAX}} - I_{\text{MIN}})]$
 $= (3.2\text{V} - 100\text{mV}) / 100\text{m}\Omega \times [1\text{A} - (-1\text{A})] = 15.5 \text{ V/V}$

The resistor values selected for R1 and R3 was 1kΩ. 15.4kΩ was selected for R2 and R4 because this number is

the nearest standard value. Therefore, the ideal gain of the difference amplifier is 15.4V/V.

The gain error of the circuit primarily depends on R1 through R4. As a result of this dependence, 0.1% resistors were selected. This configuration reduces the likelihood that the design requires a two-point calibration. A simple one-point calibration, if desired, removes the offset errors introduced by the 0.5% resistors.

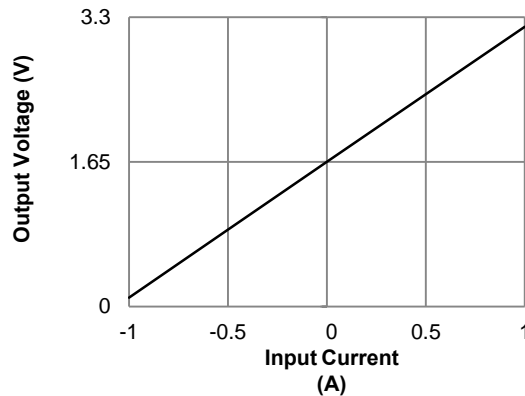

Figure7. Bidirectional Current-Sensing Circuit Performance:Output Voltagevs. Input Current

HIGH-SIDE VOLTAGE-TO-CURRENT(V-I)CONVERTER

The circuit shown in Figure 8 is a high-side voltage-to-current (V-I) converter. It translates in input voltage of 0V to 2V to and output current of 0mA to 100mA.

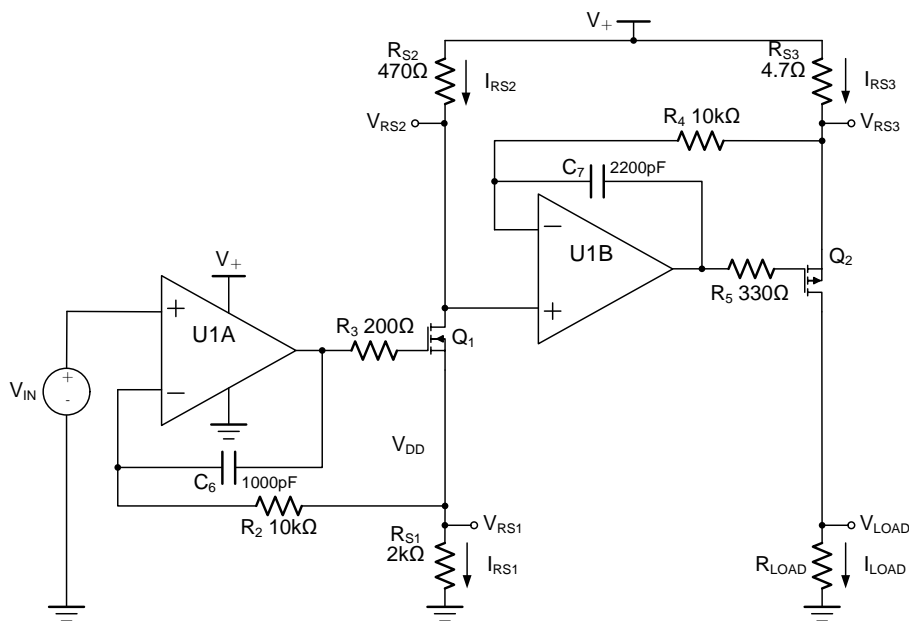

Figure8. Bidirectional Current-Sensing Schematic



Typical Application Circuits

The design requirements are as follows:

- Supply Voltage: 5V DC
- Input: 0V to 2V DC
- Output: 0mA to 100mA DC

The V-I transfer function of the circuit is based on the relationship between the input voltage, V_{IN} , and the three current sensing resistors, R_{S1} , R_{S2} , and R_{S3} . The relationship between V_{IN} and R_{S1} determines the current that flows through the first stage of the design. The current gain from the first stage to the second stage is based on the relationship between R_{S2} and R_{S3} .

For a successful design, pay close attention to the dc characteristics of the operational amplifier chosen for the application. To meet the performance goals, this application benefits from an operational amplifier with low offset voltage, low temperature drift, and rail-to-rail output. The MCP6V77T-E/MS CMOS operational amplifier is a high-precision, typically $2\mu V$ offset, $5nV/^\circ C$ drift amplifier optimized for low-voltage, single-supply operation with an output swing to within 15mV (at $R_L = 10k\Omega$) of the positive rail. The MCP6V77T-E/MS family uses chopping techniques to provide low initial offset voltage and near-zero drift over time and temperature. Low offset voltage and low drift reduce the offset error in the system, making these devices appropriate for precise dc control. The rail-to-rail output stage of the MCP6V77T-E/MS ensures that the output swing of the operational amplifier is able to fully control the gate of the MOSFET devices within the supply rails. Figure 9 shows the measured transfer function for this circuit. The low offset voltage and offset drift of the MCP6V77T-E/MS facilitate excellent dc accuracy for the circuit.

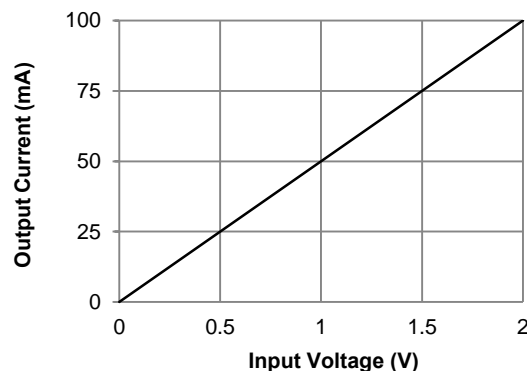

Figure9. Measured Transfer Function for High-Side V-I Converter

SINGLE-SUPPLY INSTRUMENTATION AMPLIFIER

The extremely low offset voltage and drift, high open-loop gain, high common-mode rejection, and high power supply rejection of the MCP6V77T-E/MS make them excellent op-amp choices as discrete, single-supply instrumentation amplifiers.

Figure 10 shows the classic 3-op-amp instrumentation amplifier using the MCP6V77T-E/MS. The key to High CMRR for the instrumentation amplifier are resistors that are well matched for both the resistive ratio and relative drift. For true difference amplification, matching of the resistor ratio is very important, where:

- $R5/R2 = R6/R4$
- $R_{G1} = R_{G2}$, $R1 = R3$, $R2 = R4$, $R5 = R6$
- $V_{OUT} = (V_{IN1} - V_{IN2}) \times (1 + R1 / R_{G1}) \times (R5 / R2)$

The resistors are important in determining the performance over manufacturing tolerances, time, and temperature. Assuming a perfect unity-gain difference amplifier with infinite common-mode rejection, a 1% tolerance resistor matching results in only 34dB of common-mode rejection. Therefore, at least 0.01% or better resistors are recommended.

To build a discrete instrumentation amplifier with external resistors without compromising on noise, pay close attention to the resistor values chosen. R_{G1} and R_{G2} each have thermal noise that is amplified by the total noise gain of the instrumentation amplifier and, therefore, a sufficiently low value must be chosen to reduce thermal noise contribution at the output while still providing an accurate measurement.



Typical Application Circuits

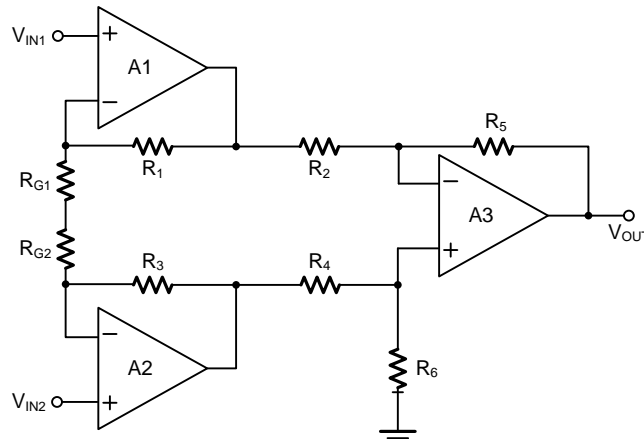

Figure10. Discrete3-Op-amp Instrumentation Amplifier

Figure 11 shows the external resistors noise contribution referred to the output .

Resistor	Value	Resistor Thermal Noise	Thermal Noise Referred to Output
R _{G1}	0.4 kΩ	2.57 nV/√ Hz	128.30 nV/√ Hz
R _{G2}	0.4 kΩ	2.57 nV/√ Hz	128.30 nV/√ Hz
R ₁	10 kΩ	12.83 nV/√ Hz	25.66 nV/√ Hz
R ₂	10 kΩ	12.83 nV/√ Hz	25.66 nV/√ Hz
R ₃	10 kΩ	12.83 nV/√ Hz	25.66 nV/√ Hz
R ₄	10 kΩ	12.83 nV/√ Hz	25.66 nV/√ Hz
R ₅	20 kΩ	18.14 nV/√ Hz	18.14 nV/√ Hz
R ₆	20 kΩ	18.14 nV/√ Hz	18.14 nV/√ Hz

Figure11. Thermal Noise Contribution Example

Note that A1 and A2 have a high gain of $1 + R_1/R_{G1}$. Therefore, use a high precision, low offset voltage and low noise amplifier for A1 and A2, such as the MCP6V77T-E/MS. Conversely, A3 operates at a much lower gain and has a different set of op-amp requirements. Its input noise, referred to the overall instrumentation amplifier input, is divided by the first stage gain and is not as important. Note that the input offset voltage and the input voltage noise of the amplifiers are also amplified by the overall noise gain. Any unused channel of the MCP6V77T-E/MS must be configured in unity gain with the input common-mode voltage tied to the midpoint of the power supplies.

Understanding how noise impacts a discrete instrumentation amplifier or a difference amplifier (the second stage of a 3-op-amp instrumentation amplifier) is important, because they are commonly used in many different applications.

LOAD CELL (STRAIN GAGE) SENSOR SIGNAL CONDITIONING

The MCP6V77T-E/MS, with its ultralow offset, drift, and noise, is well suited to signal condition a low level sensor output with high gain and accuracy. A weigh scale (load cell) is an example of an application

with such requirements. Figure 12 shows a configuration for a single-supply, precision, weigh scale measurement system. The MCP6V77T-E/MS is used at the front end for amplification of the low level signal from the load cell.

Current flowing through a PCB trace produces an IR voltage drop; with longer traces, this voltage drop can be several millivolts or more, introducing a considerable error. A 1 inch long, 0.005 inch wide trace of 1 oz copper has a resistance of approximately 100mΩ at room temperature. With a load current of 10mA, the resistance can introduce a 1mV error.

Typical Application Circuits

Therefore, a 6-wire load cell is used in the circuit. The load cell has two sense pins, in addition to excitation, ground, and two output connections. The sense pins are connected to the high side (excitation pin) and low side (ground pin) of the Wheatstone bridge. The voltage across the bridge can then be accurately measured regardless of voltage drop due to wire resistance. The two sense pins are also connected to the



analog-to-digital converter (ADC) reference inputs for a ratio-metric configuration that is immune to low frequency changes in the power supply excitation voltage.

The MCP6V77T-E/MS is configured as the first stage of a 3-op-amp instrumentation amplifier to amplify the low level amplitude signal from the load cell by a factor of $1 + 2 R_1/R_G$. Capacitors C1 and C2 are placed in the feedback loops of the amplifiers and interact with R1 and R2 to perform low-pass filtering. This filtering limits the amount of noise entering the Σ - Δ ADC. In addition, C3 , C4 , C5 , R3 and R4 provide further common-mode and differential mode filtering to reduce noise and unwanted signals.

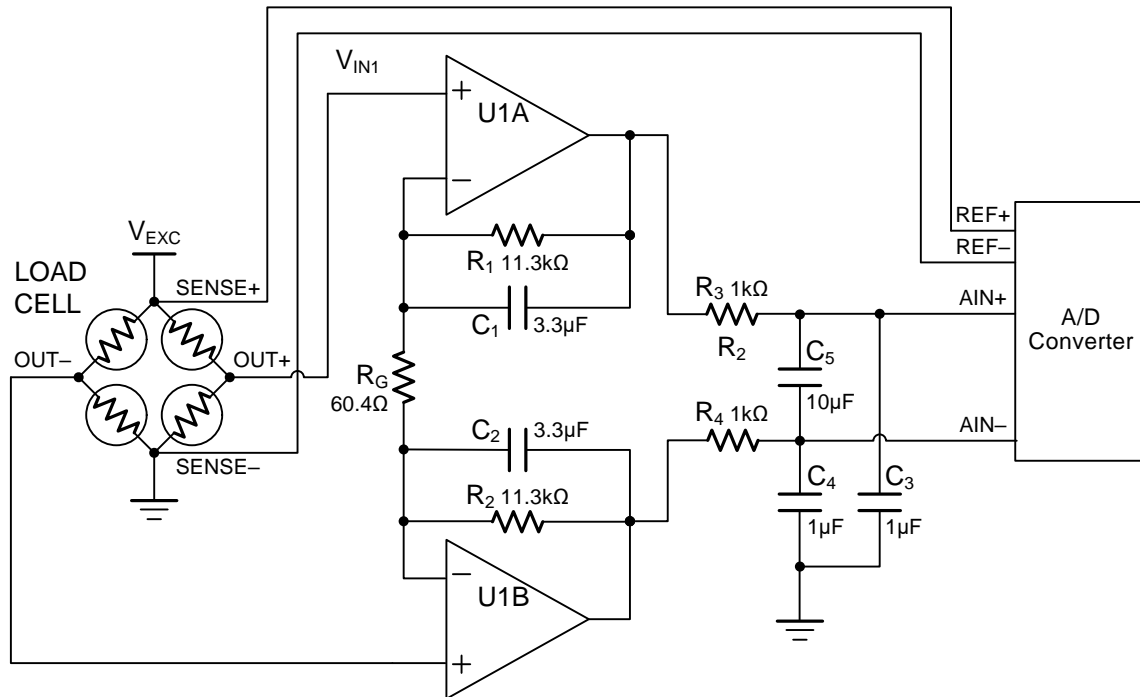
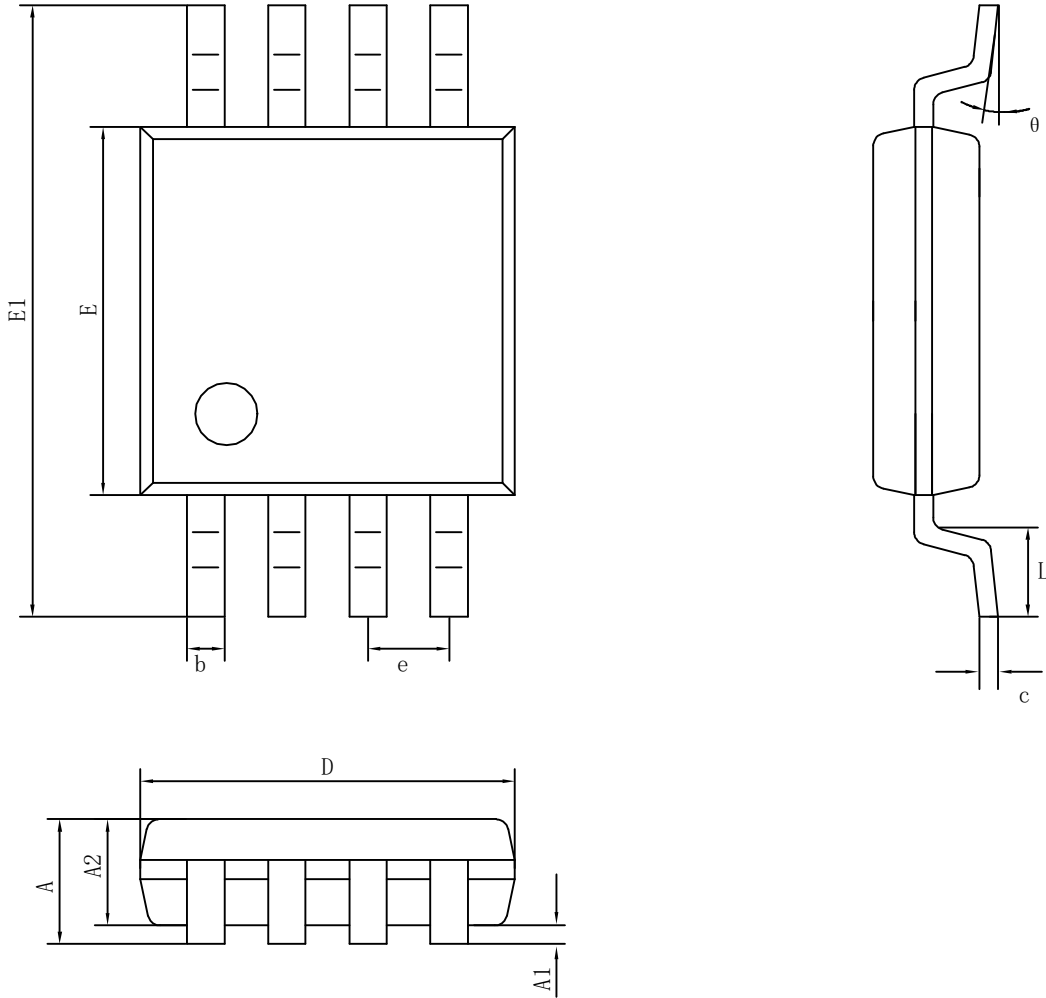

Figure12. Precision Weigh Scale Measurement System



Package Information

MSOP-8



Symbol \ Size	Dimensions In Millimeters		Symbol \ Size	Dimensions In Inches	
	Min (mm)	Max (mm)		Min (in)	Max (in)
A	0.820	1.100	A	0.320	0.043
A1	0.020	0.150	A1	0.001	0.006
A2	0.750	0.950	A2	0.030	0.037
b	0.250	0.380	b	0.010	0.015
c	0.090	0.230	c	0.004	0.009
D	2.900	3.100	D	0.114	0.122
e	0.65 (BSC)		e	0.026 (BSC)	
E	2.900	3.100	E	0.114	0.122
E1	4.750	5.050	E1	0.187	0.199
L	0.400	0.800	L	0.016	0.031
θ	0°	6°	θ	0°	6°



Attention

- Any and all HUA XUAN YANG ELECTRONICS products described or contained herein do not have specifications that can handle applications that require extremely high levels of reliability, such as life-support systems, aircraft's control systems, or other applications whose failure can be reasonably expected to result in serious physical and/or material damage. Consult with your HUA XUAN YANG ELECTRONICS representative nearest you before using any HUA XUAN YANG ELECTRONICS products described or contained herein in such applications.
- HUA XUAN YANG ELECTRONICS assumes no responsibility for equipment failures that result from using products at values that exceed, even momentarily, rated values (such as maximum ratings, operating condition ranges, or other parameters) listed in products specifications of any and all HUA XUAN YANG ELECTRONICS products described or contained herein.
- Specifications of any and all HUA XUAN YANG ELECTRONICS products described or contained herein stipulate the performance, characteristics, and functions of the described products in the independent state, and are not guarantees of the performance, characteristics, and functions of the described products as mounted in the customer's products or equipment. To verify symptoms and states that cannot be evaluated in an independent device, the customer should always evaluate and test devices mounted in the customer's products or equipment.
- HUA XUAN YANG ELECTRONICS CO.,LTD. strives to supply high-quality high-reliability products. However, any and all semiconductor products fail with some probability. It is possible that these probabilistic failures could give rise to accidents or events that could endanger human lives, that could give rise to smoke or fire, or that could cause damage to other property. When designing equipment, adopt safety measures so that these kinds of accidents or events cannot occur. Such measures include but are not limited to protective circuits and error prevention circuits for safe design, redundant design, and structural design.
- In the event that any or all HUA XUAN YANG ELECTRONICS products(including technical data, services) described or contained herein are controlled under any of applicable local export control laws and regulations, such products must not be exported without obtaining the export license from the authorities concerned in accordance with the above law.
- No part of this publication may be reproduced or transmitted in any form or by any means, electronic or mechanical, including photocopying and recording, or any information storage or retrieval system, or otherwise, without the prior written permission of HUA XUAN YANG ELECTRONICS CO.,LTD.
- Information (including circuit diagrams and circuit parameters) herein is for example only ; it is not guaranteed for volume production. HUA XUAN YANG ELECTRONICS believes information herein is accurate and reliable, but no guarantees are made or implied regarding its use or any infringements of intellectual property rights or other rights of third parties.
- Any and all information described or contained herein are subject to change without notice due to product/technology improvement, etc. When designing equipment, refer to the "Delivery Specification" for the HUA XUAN YANG ELECTRONICS product that you intend to use.