

BT152-D

MAIN FEATURES

Symbol	Value	Unit
$I_{T(RMS)}$	12	A
V_{DRM}/V_{RRM}	650	V

DESCRIPTION:

With high ability to withstand the shock loading of large current, BT152-D of silicon controlled rectifiers provides high dV/dt rate with strong resistance to electromagnetic interference. It is especially recommended for use on solid state relay, motorcycle, power charger, T-tools etc. From all three terminals to external heatsink.

Package TO-252 is RoHS compliant.

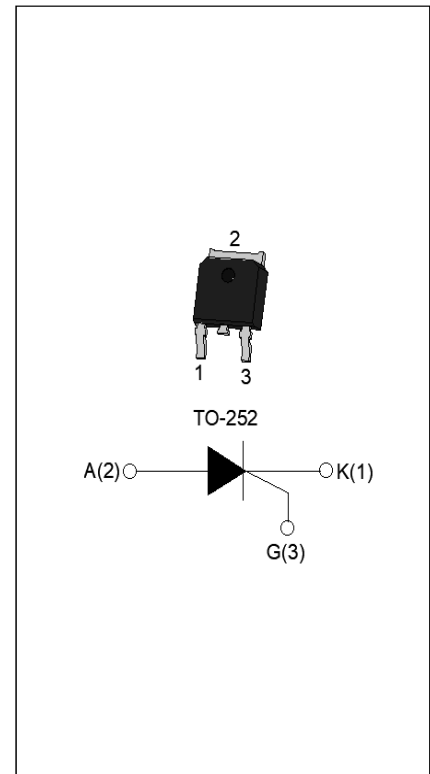

ABSOLUTE MAXIMUM RATINGS

Parameter	Symbol	Value	Unit
Storage junction temperature range	T_{stg}	-40-150	$^{\circ}C$
Operating junction temperature range	T_j	-40-125	$^{\circ}C$
Repetitive peak off-state voltage ($T_j=25^{\circ}C$)	V_{DRM}	650	V
Repetitive peak reverse voltage ($T_j=25^{\circ}C$)	V_{RRM}	650	V
RMS on-state current ($T_c \leq 80^{\circ}C$)	$I_{T(RMS)}$	12	A
Non repetitive surge peak on-state current (full cycle, $t_p=20ms$, $T_j=25^{\circ}C$)	I_{TSM}	120	A
I^2t value for fusing ($t_p=10ms$, $T_j=25^{\circ}C$)	I^2t	144	A^2s
Critical rate of rise of on-state current ($T_j=125^{\circ}C$)	di/dt	50	$A/\mu s$
Peak gate current ($t_p=20\mu s$, $T_j=125^{\circ}C$)	I_{GM}	4	A
Average gate power dissipation ($T_j=125^{\circ}C$)	$P_{G(AV)}$	1	W

ELECTRICAL CHARACTERISTICS ($T_j=25^{\circ}\text{C}$ unless otherwise specified)

Symbol	Test Condition	Value		Unit
I_{GT}	$V_D = 12\text{V}$ $R_L = 100\Omega$	MAX.	15	mA
V_{GT}		MAX.	1.5	V
V_{GD}	$V_D = V_{DRM}$ $T_j = 125^{\circ}\text{C}$ $R_L = 100\Omega$	MIN.	0.2	V
I_L	$I_G = 1.2I_{GT}$	MAX.	40	mA
			60	
I_H	$I_T = 500\text{mA}$	MAX.	30	mA
dV/dt	$V_D = 2/3V_{DRM}$ $T_j = 125^{\circ}\text{C}$	MIN.	500	V/ μs

STATIC CHARACTERISTICS

Symbol	Parameter		Value(MAX.)	Unit
V_{TM}	$I_{TM} = 30\text{A}$ $t_p = 380\mu\text{s}$	$T_j = 25^{\circ}\text{C}$	1.50	V
V_{TO}	Threshold voltage	$T_j = 125^{\circ}\text{C}$	0.86	V
R_D	Dynamic resistance	$T_j = 125^{\circ}\text{C}$	36.6	$\text{m}\Omega$
I_{DRM}	$V_D = V_{DRM}$ $V_R = V_{RRM}$	$T_j = 25^{\circ}\text{C}$	5	μA
I_{RRM}		$T_j = 125^{\circ}\text{C}$	1	mA

THERMAL RESISTANCES

Symbol	Parameter	Value	Unit
$R_{th(j-c)}$	junction to case (AC)	2.05	$^{\circ}\text{C}/\text{W}$

ORDERING INFORMATION

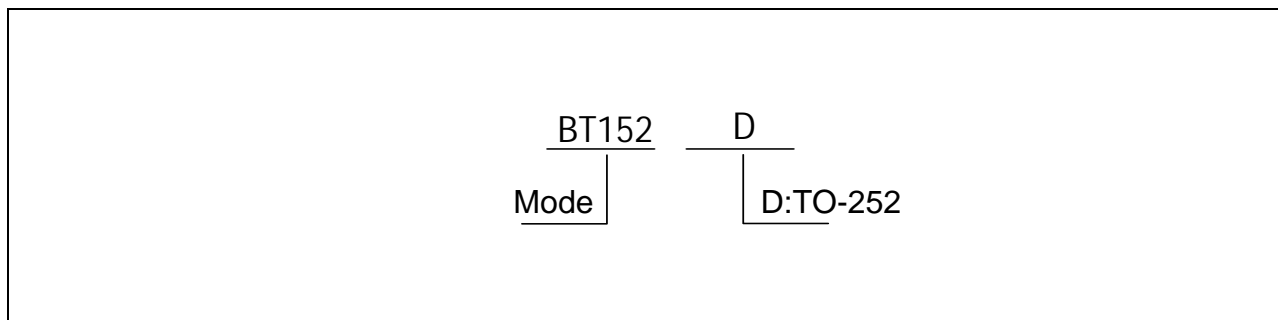

MARKING

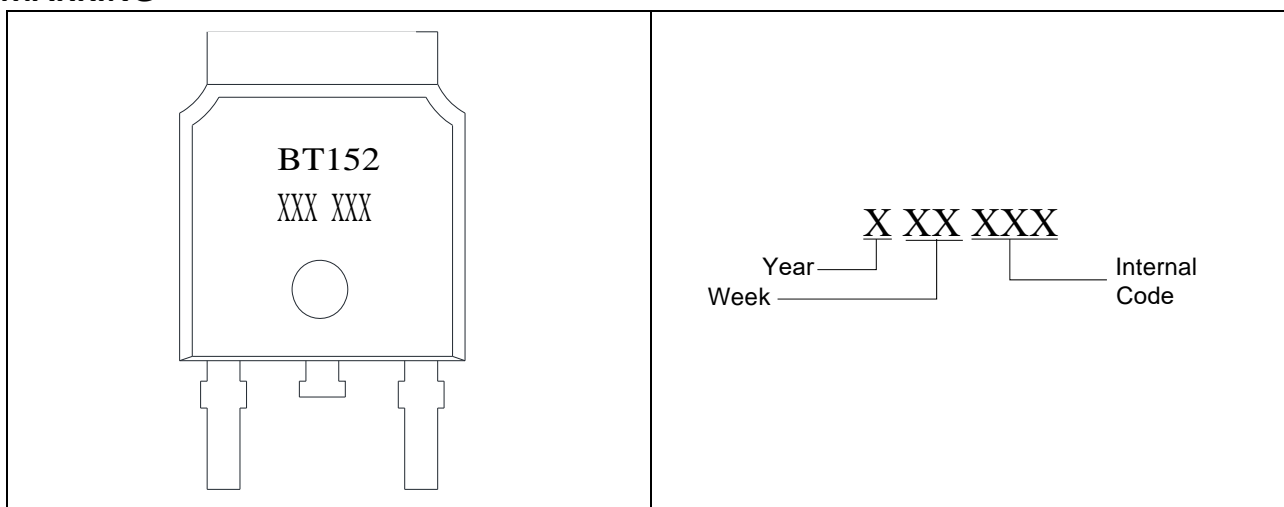

ORDERING INFORMATION

Order code	Voltage V _{DRM} /V _{R_{RM}} (V)	Package	Base qty. (pcs)	Delivery mode
BT152-D	650	TO-252	2500	Tube

PACKAGE MECHANICAL DATA

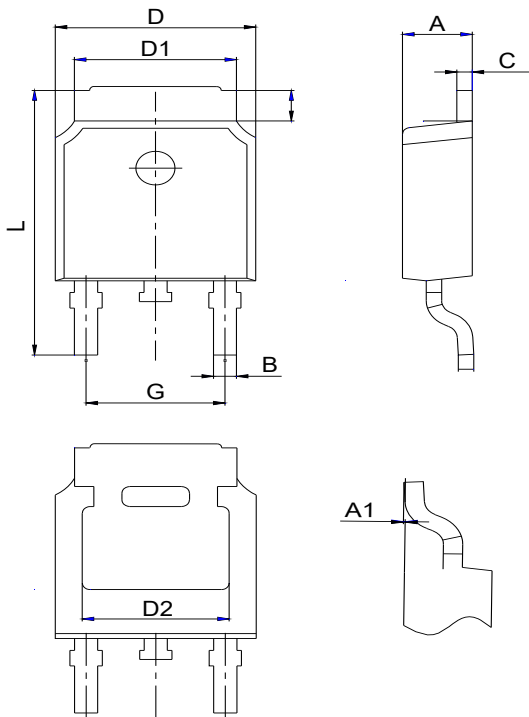

TO-252

Ref.	Dimensions		
	Milimeters		
	Min.	Typ.	Max.
A	2.10	2.30	2.50
A1	/	/	0.13
B	0.47	0.67	0.87
C	0.30	0.50	0.70
D	6.40	6.60	6.80
D1	5.13	5.33	5.53
D2	4.830REF		
G	4.37	4.57	4.77
L	9.80	10.00	10.20

DELIVERY MODE

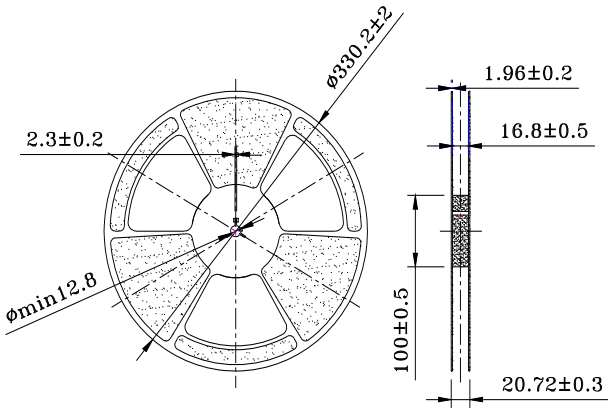
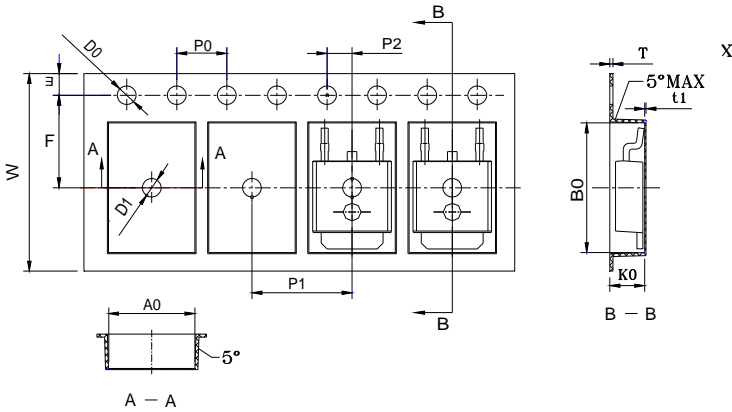

Ref.	Dimensions		
	Millimeters		
	Min.	Typ.	Max.
W	15.90	16.00	16.10
E	1.65	1.75	1.85
F	7.40	7.50	7.60
D0	1.50	1.55	1.60
D1	1.50	/	/
P0	3.90	4.00	4.10
P1	7.90	8.00	8.10
P2	1.90	2.00	2.10
10P0	39.8	40.00	40.20
A0	6.80	6.90	7.00
B0	10.40	10.50	10.60
K0	2.60	2.70	2.80
T	0.25	0.30	0.35
t1	0.10	/	/

PACKAGE	OUTLINE	REEL (PCS)	PER CARTON (PCS)
TO-252	REEL	2,500	5,000

FIG.1 Maximum power dissipation versus RMS on-state current

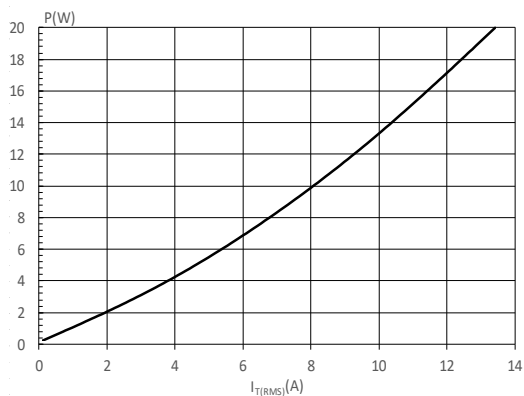

FIG.2: RMS on-state current versus case temperature

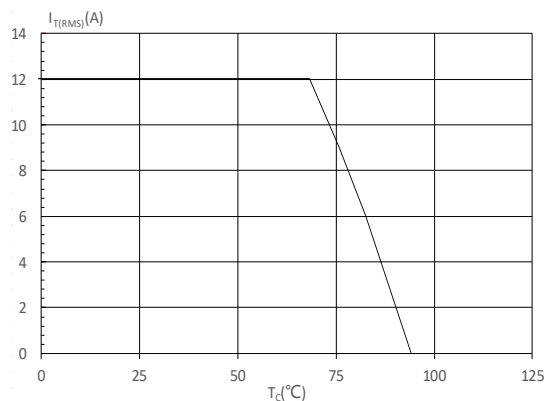

FIG.3: Surge peak on-state current versus number of cycles

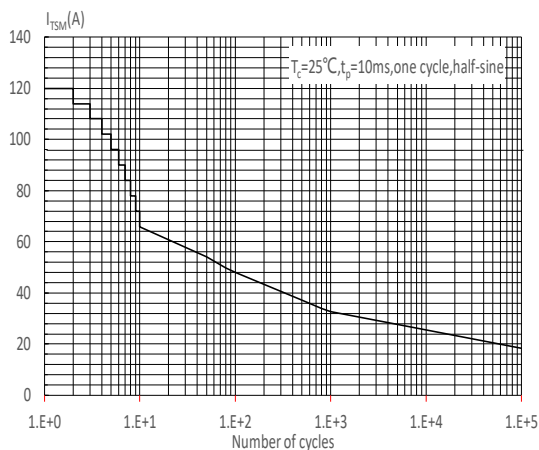

FIG.5: Non-repetitive surge peak on-state current for a sinusoidal pulse with width $t_p < 10\text{ms}$, and corresponding value of I^2t ($di/dt < 100\text{A}/\mu\text{s}$)

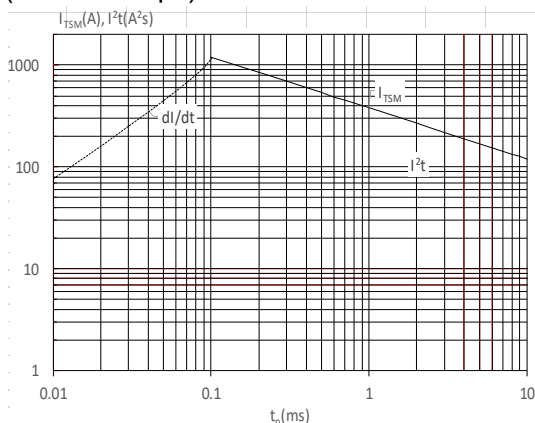

FIG.4: On-state characteristics

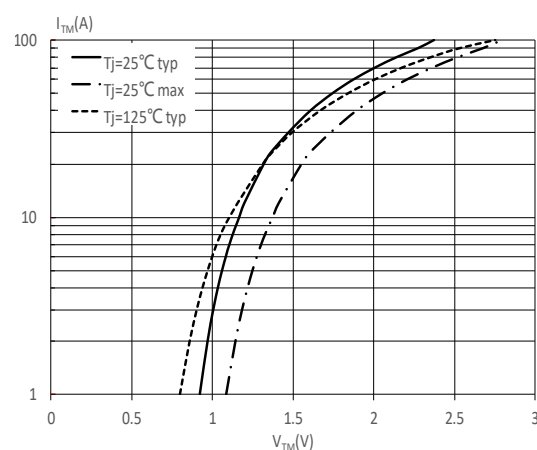

FIG.6: Relative variations of gate trigger current, holding current and latching current versus junction temperature

