

Description

The **GTA2718B-3** is a small package, single-ended output bottom port analog MEMS microphone, consists of a MEMS sensor and a low noise level ASIC.

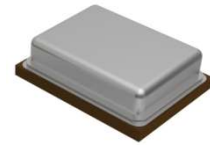

Top View

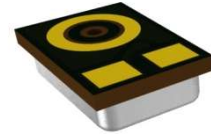

Bottom View

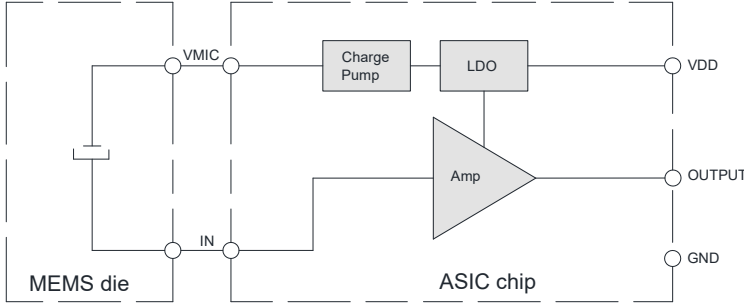

Fig. 1 Microphone block diagram

Key Features

- ✧ 2.75x1.85x1.0mm Bottom Port
- ✧ Single Ended Output
- ✧ High SNR
- ✧ Narrow Sensitivity +/-1dB
- ✧ RF Shielded
- ✧ Compatible with Standard SMD Reflow Technology
- ✧ RoHS Compliance & Halogen Free

Typical Applications

- ✧ TWS Earphone
- ✧ Wireless Headsets
- ✧ Smart Speakers
- ✧ Wearable Electronics
- ✧ Portable Electronics
- ✧ Smart Home Electronics

Maximum Ratings

Stresses at the maximum ratings shown in Table 1 may cause permanent damage to the device. These are stress ratings only at which the device may not function when an operation at these or any other condition beyond those specified under "Electro-Acoustic Specifications".

Table 1 Maximum Ratings

Parameter	Maximum Ratings	Unit
Supply voltage	4.2	V
Operation temperature range	-40~85	°C
Storage temperature range	-40~100	°C

Electro-Acoustic Specifications

Table 2 Electrical Specifications

Test condition: +25±2°C, 60%~70% RH, 86~106Kpa, Vdd=2.75V, no load, unless otherwise specified.

No.	Parameter	Symbol	Condition	Min.	Nom.	Max.	Unit
1	Sensitivity	S	f=1kHz, Pin=1Pa, 0dB=1V/Pa	-39	-38	-37	dB
2	Operating Voltage	V _{DD}		2.3	2.75	3.6	V
3	Directivity			Omni-directional			
4	Polarity		Sound pressure increase	Output voltage increase			
5	Sensitivity vs. Voltage	ΔS	Vs= 3.6V to 2.3V	<0.5			dB
6	Output Impedance	Z _{OUT}	f=1kHz			400	Ω
7	Current Consumption	I	2.3 V to 3.6V		135	200	μA
8	S/N Ratio	S/N	f=1kHz, BW=20-20kHz, A-Weighted	64	66		dBA
9	Total Harmonic Distortion	THD	94dB SPL @1KHz		0.05	0.5	%
			125dB SPL @1KHz		1		
10	Acoustic Overload Point	AOP	THD 10%@1KHz		129		dB SPL
11	Power Supply Rejection	PSR	100mVpp Square wave @217Hz, A-weighted		-102	-90	dB
12	Power Supply Rejection Ratio	PSRR	200mVpp Sinewave @1KHz	60	71		dB
13	DC output	VDC			1.1		V
14	Output load	C _{load}				100	pF
		R _{load}		8			KΩ

Note: Frequency response, sensitivity and current consumption are tested by 100% on product line.

Performance Curves

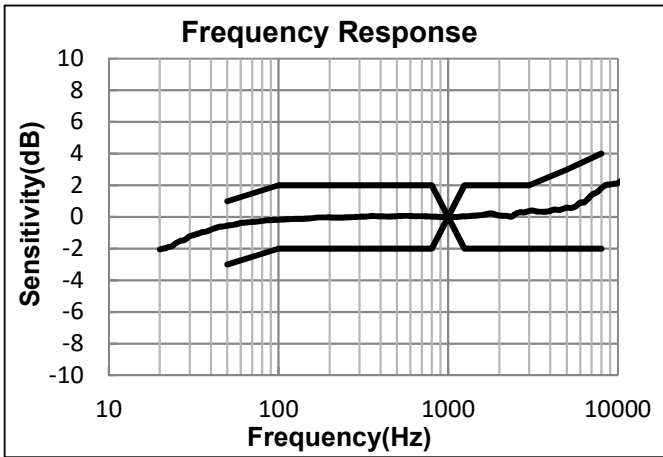

Fig.2 Frequency response curve normalized to 1 kHz

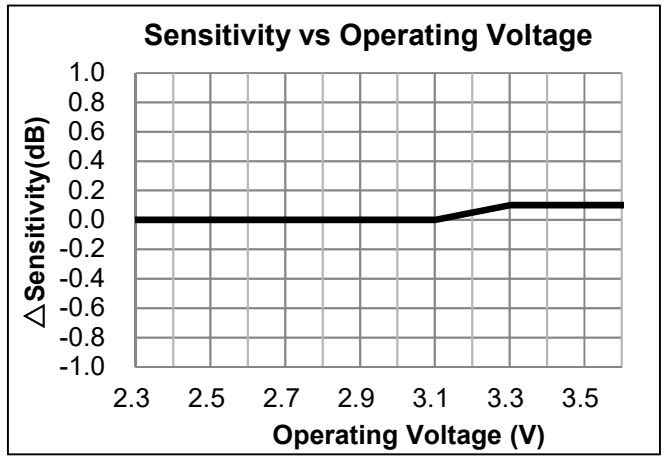

Fig. 3 Sensitivity vs Operating Voltage

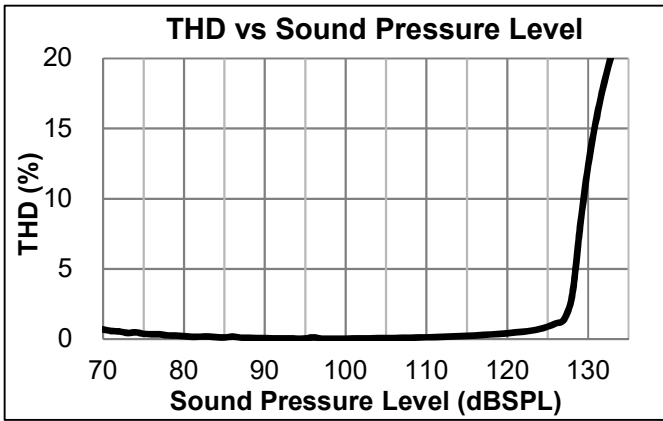

Fig. 4 Typical THD vs Sound Pressure Level

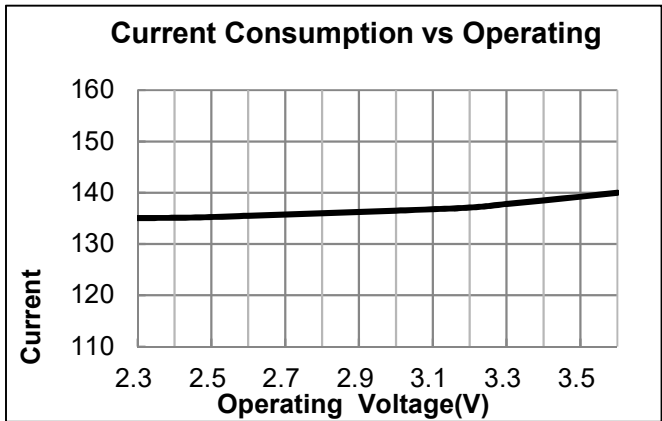

Fig. 5 Typical Current vs Operating Voltage

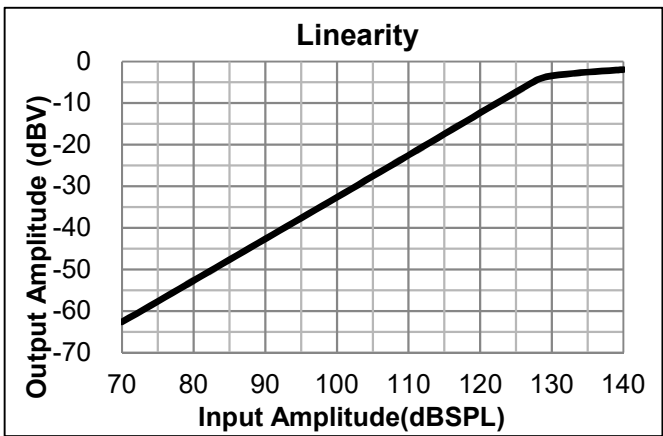

Fig. 6 Linearity

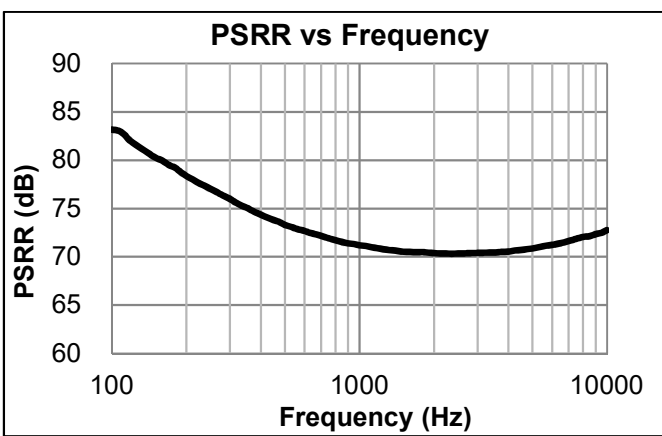

Fig. 7 Typical PSRR curve

Measurement System Setup

Test signal: Sinusoid, Sweep,
Step: 1/12 octave

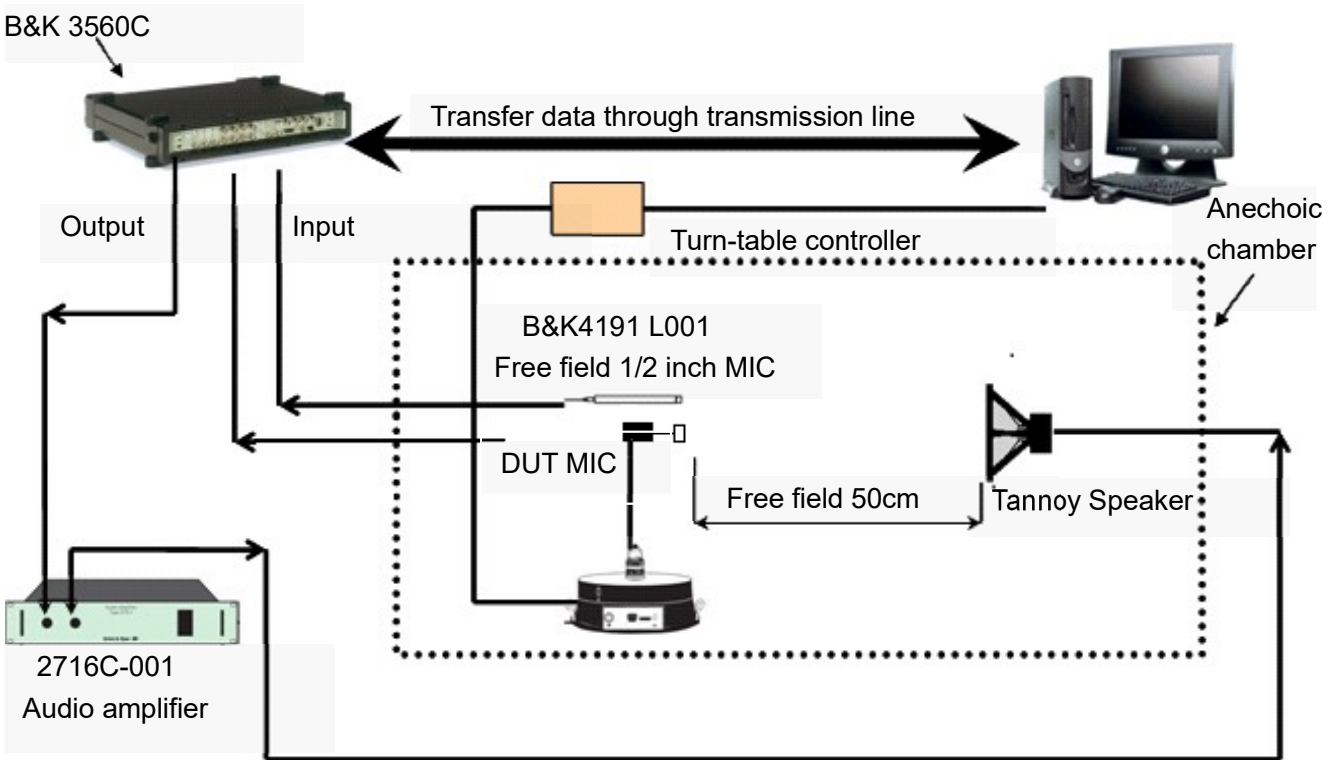

Fig. 8 Measurement System Setup

Typical Application Circuit

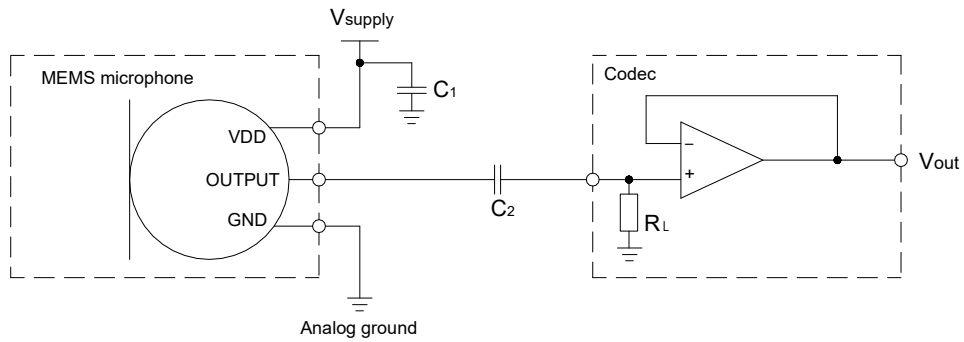

Fig. 9 Typical Application Circuit

Power supply decoupling :

A 0.1uF ceramic type decoupling capacitor C₁ is strongly recommended for every microphone and it should be placed as close to the VDD pad to reduce the noise on power supply;

The trace connected to each pad of capacitor should be as short as possible, and should stay on one layer of PCB without via. For the best performance, recommend to place the capacitor equidistance from power and ground pins of microphone, or slightly closer to the power pin if space not allowed. System ground should connect to far side of the capacitor, as shown in fig.10.

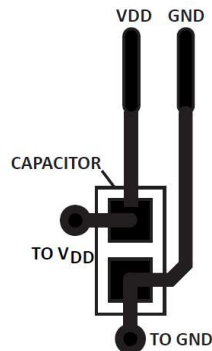

Fig. 10 Recommended Power Supply Decoupling Capacitor Layout

Low frequency roll-off :

DC-blocking capacitor C₂ is required on the output signal line. The 3-dB cut-off frequency can be calculated using follow equation which is related to DC-blocking capacitor C₂ and input resistance of the input amplifier.

$$3\text{dB cut-off frequency} = 1/2\pi R_L C_2$$

In order to get a cut-off frequency below 20 Hz, minimum 1uF value of C₂ and minimum 20KΩ value of input resistance of the input amplifier is recommended.

Mechanical Specifications

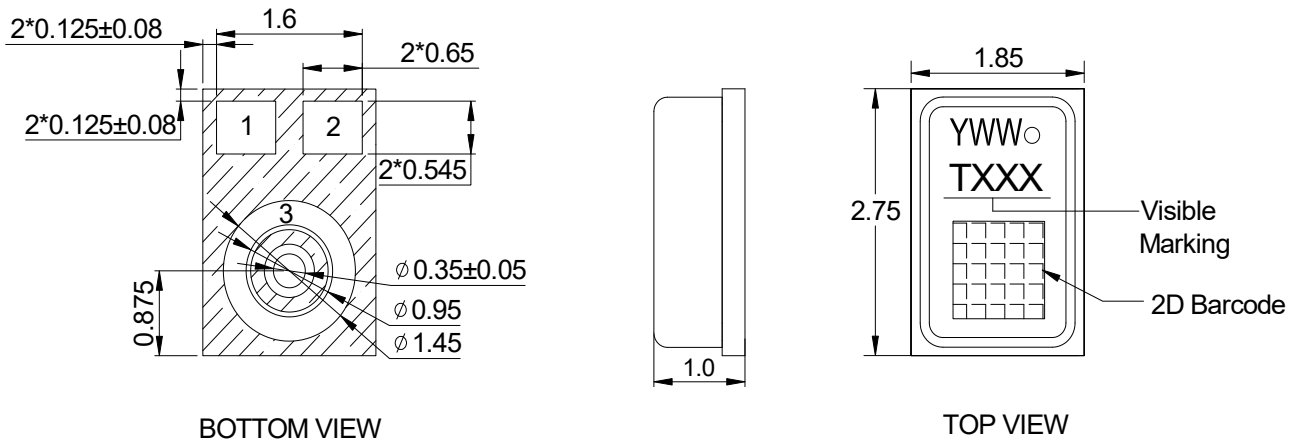

Unit: mm Unmarked Tolerance: ± 0.1 (mm)

Fig. 11 Dimension

Item	Dimension	Tolerance
Length	2.75	±0.1
Width	1.85	±0.1
Height	1.0	±0.1
Acoustic Port	0.35	±0.05

PIN	Definition	Description
1	VDD	Power Supply
2	Output	Signal Output
3	GND	Ground

Note:

- All Ground Pin must be connected to the ground in end application
- Identification Marking

Y: Year WW: Week ○: Polarity sign

T: GETTOP XXX: Serial Number



2D Barcode

Reliability Specifications

After conducting any of the following tests, the sensitivity change of DUT shall be less than $\pm 3\text{dB}$ from its initial value unless otherwise noted, and shall keep its initial operation and appearance.

Table 3 Reliability Specifications

No.	Item	Test condition
1	Preconditioning	24 hour bake at 125°C, followed by 168 hours at 85°C, 85%RH, followed by 3 passes solder reflow only for the following three tests: High Humidity & High Heat operating Test High Humidity & High Heat operating Test Thermal Shocking Test
2	Hi-Temperature Storage Test	105 \pm 3°C, 1000h, recover for two hours
3	Hi-Temperature operating Test	105 \pm 3°C, under upper limit bias, 1000h, recover for two hours
4	Low-Temperature storage Test	-40 \pm 3°C, 1000h, recover for two hours
5	Low-Temperature operating Test	-40 \pm 3°C, under upper limit bias, 1000h, recover for two hours
6	High Humidity & High Heat operating Test	85 \pm 3°C, 85%RH, under upper limit bias, 1000h, recover for two hours, there should be no corrosion and deformation inside of microphone after testing
7	High Humidity & High Heat operating Test	65 \pm 3°C, 95%RH, under upper limit bias, 168h, recover for two hours, there should be no corrosion and deformation inside of microphone after testing
8	Thermal Shocking Test	Double-Case Method, -40°C for 15mins \rightarrow 125°C for 15 mins, 100 cycles, recover for two hours
9	Vibration Test	Each 12mins for X, Y and Z axes, Frequency: 20~2000Hz, Peak Acceleration 20g, recover for two hours
10	Drop Test	Height: 1.5m Fixture Weight: 150g (Sound Hole Diameter in the fixture is $\geq 0.8\text{mm}$) Reference Surface: slippery marble floor Duration: 4 corners*4 times, 6 faces*4 times The sensitivity change should be less than 1dB after testing
11	Tumbling Test	Height: 1.0m Fixture Weight: 150g (Sound Hole Diameter in the fixture is $\geq 0.8\text{mm}$) Duration: 300 times Recommended Time: 10-11times/Min The sensitivity change should be less than 1dB after testing

12	ESD Test 1	<p>a. HMB Discharge Position: I/O pins Charge Voltage: ±3000V Discharge Network: 100pF & 1500Ω</p> <p>b. CDM Discharge Position: I/O pins Charge Voltage: ±250V</p>
13	ESD Test 2	<p>The tests are performed acc. to IEC61000-4-2 level 3:</p> <p>a. Contact Discharge Discharge Position: Output of Microphone Charge Voltage:±6000VDC Discharge Network:150pF & 330Ω</p> <p>b. Air Discharge Discharge Position: Sound Hole Charge Voltage:±8000VDC Discharge Network:150pF & 330Ω</p>
14	Structure Shock Test	10000g, Duration: 0.1ms, each 3 shocks for X/Y/Z 3 axes, The sensitivity change should be less than 1dB after testing
15	Reflow	3 reflow cycles with peak temperature of +260°C according to reflow profile

Packaging Details

- * Use ESD reel and tape for microphone packaging.
- * Anti-static measures should be applied during packaging operation.

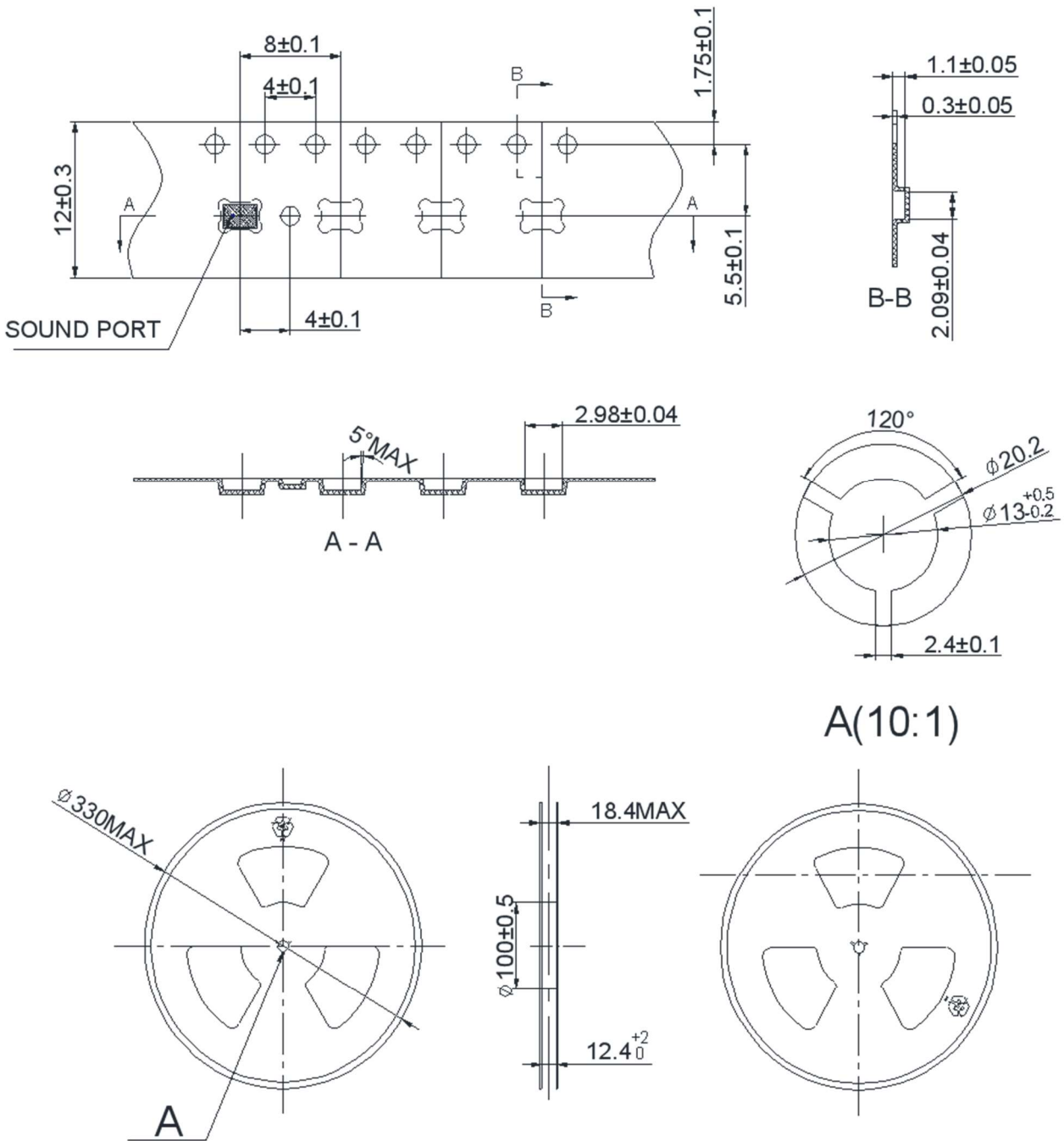
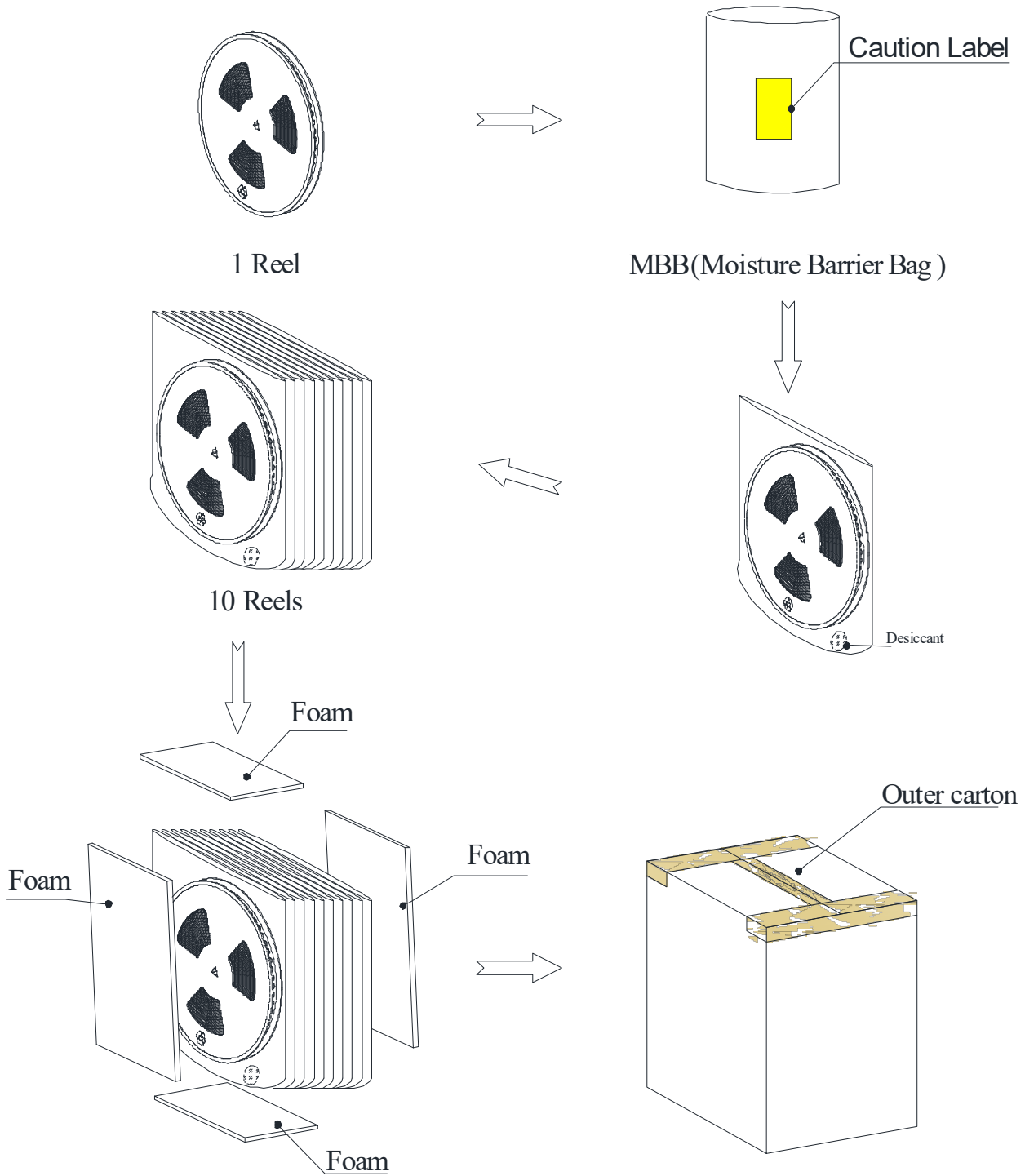

Fig. 12 Packaging



Tape and Reel	φ330mm	5,500PCS×1=5,500PCS
Shipping Box	215mm*370mm*370mm	5,500PCS×10=55,000PCS

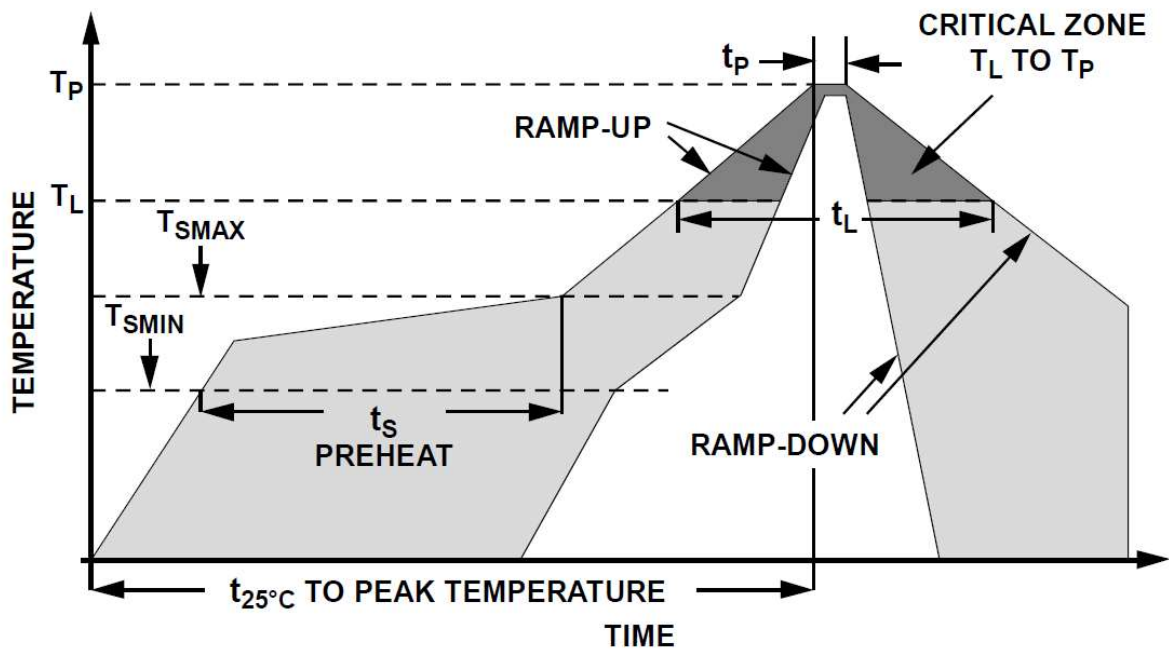

Fig. 13 Reflow Profile

Additional Notes:

- Mic should cool to room temp before next flow cycle if more reflow is needed.
- No more than 3 times reflow is recommended.
- Do not board wash by liquid or ultrasonic after the reflow process.
- Do not pull a vacuum over port hole of the microphone.
- Do not insert any object in port hole of device at any time.
- Suggest SMT the microphone at last time if double side PCBA used.
- Do not seal sound port during reflow .
- If there is any leakage risk, the peak temperature should be set to less than $240^{\circ}C$ or more than $255^{\circ}C$.

Recommended nozzle for reflow MIC

External diameter is $\Phi 1.3\text{mm}$
Inside diameter is $\Phi 1.0\text{mm}$

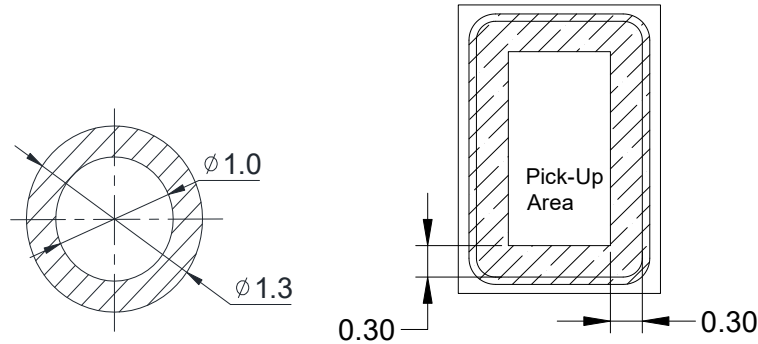

Fig. 14 Recommended nozzle for reflow MIC and Pick-up Area

Special Cautions

Air Rifle Cleaning Restriction

Do not bring air rifle to the port hole directly.

Recommended Condition:

- Air pressure < 0.3MPa;
- Distance > 5cm;
- Time < 5 sec.

Package

Do not vacuum seal unused material for storage. Vacuum Sealing can cause mic damage.

Storage

The component needs to meet the requirement of MSL(Moisture Sensitivity Level) class 1. Please keep MICs in warehouse with humidity less than 75% and without sudden temperature change, acid air, and any other harmful air or strong magnetic field.

Please protect products against moist, shock, sunburn and pressure.

Please take proper measures against ESD in the process of assembly and transportation.

Please use the shipping package for long-term storage.

Discard

For microphones to be wasted, customer shall follow the regulation of Waste Electrical and Electronic Equipment (WEEE) Directive (2002/96/EC).

Notes: More application suggestions can be found in the latest "MEMS Microphone Application Notes".

Specification Revisions

Date	Version	Description
08-16-2024	V1.1	Initial release
11-05-2024	V1.2	Updated AOP limit
11-22-2024	V2.0	Updated AOP
07-31-2025	V3.0	Updated Gettop information

Gettop 公司销售/技术支持联系方式 (Http://www.gettopacoustic.com)

Gettop Acoustic Co.,Ltd.

Tel: +86 536 2283666

E-Mail: gettop@gettopacoustic.com
sales@gettopacoustic.com

Website: [Http://www.gettopacoustic.com](http://www.gettopacoustic.com)

Address: NO.68 Fengshan Road.,Fangzi Development Zone, Weifang,Shandong,China

共达电声股份有限公司

电话: +86 536 2283666

邮箱: gettop@gettopacoustic.com
sales@gettopacoustic.com

网址: [Http://www.gettopacoustic.com](http://www.gettopacoustic.com)

地址: 中国山东省潍坊市坊子区凤山路 68 号