

SA164 Series Automotive Grade Quartz Crystal

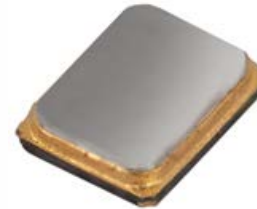

Part Dimensions:
1.6 × 1.2 × 0.45mm • 2.76mg

Features

- AEC-Q200 Compliant
- Hermetic Ceramic Surface Mount Package
- Fundamental Crystal Design
- Frequency Range 24 – 60MHz
- Frequency Tolerance, ±30ppm Standard
- Frequency Stability, ±50ppm Standard
- Operating Temperature Range to -55°C to +125°C
- Tape and Reel Packaging, EIA-418

Standard Frequencies – see Page 5 for developed frequencies.
* Check with factory for availability of frequencies not listed.

Applications

- Automotive Electronics
- Mobile Multimedia/Infotainment
- Car Navigation Systems
- Internet of Things [IoT, IIoT]
- Microcontrollers and FPGAs
- Wireless Communication
- Ethernet/GbE/SyncE
- Medical Electronics
- Commercial Military & Aerospace

Description

CTS Model SA164 incorporates a low cost, high Q, small size quartz resonator specifically developed to operate over extended temperature ranges for use in automotive electronics.

Ordering Information

Model	Frequency Code [MHz]	Mode of Oscillation	Tolerance @ +25°C	Temperature Stability	Temperature Range	Load Capacitance	Packaging
SA164	XXX	F	3	5	G	A	R
	Code Frequency		Code Tolerance		Code Temp. Range		Code Packing
	Product Frequency Code ¹		1 ±10ppm X ±15ppm 2 ±20ppm 3 ±30ppm 5 ±50ppm		I -40°C to +85°C ² G -40°C to +105°C ³ H -40°C to +125°C ⁴ N -40°C to +150°C ⁵ P -55°C to +105°C ⁵ M -55°C to +125°C ⁵		R 3k pcs./reel
		Code Mode		Code Stability		Code Capacitance Code Capacitance	
		F Fundamental		X ±15ppm 2 ±20ppm 3 ±30ppm 5 ±50ppm 6 ±100ppm 7 ±150ppm		V 7pF C 16pF K 8pF D 18pF J 9pF E 20pF A 10pF F 24pF L 12pF G 30pF B 13pF S Series	

Notes:

- 1] Refer to document 016-1454-0, Frequency Code Tables. 3-digits for frequencies <100MHz, 4-digits for frequencies 100MHz or greater.
- 2] Available with all stability codes.
- 3] Available with stability codes 3, 5, 6 and 7.
- 4] Available with stability codes 5, 6 and 7.
- 5] Stability codes 6 and 7. Contact factory for code 5 availability.

**Not all performance combinations and frequencies may be available.
Contact your local CTS Representative or CTS Customer Service for availability.**

This product is specified for use only in standard commercial applications. Supplier disclaims all express and implied warranties and liability in connection with any use of this product in any non-commercial applications or in any application that may expose the product to conditions that are outside of the tolerances provided in its specification.



Electrical Specifications

Operating Conditions

PARAMETER	SYMBOL	CONDITIONS	MIN	TYP	MAX	UNIT
Operating Temperature	T _A	-	-40		+85	°C
			-40		+105	
			-40	+25	+125	
			-40		+150	
			-55		+105	
			-55		+125	
Storage Temperature	T _{STG}	-	-55	-	+125	°C

Frequency Stability

PARAMETER	SYMBOL	CONDITIONS	MIN	TYP	MAX	UNIT
Frequency Range	f ₀	Fundamental mode		24 - 60		MHz
Frequency Tolerance	Δf/f ₀	@ +25°C		10, 15, 20, 30 or 50		±ppm
Frequency Stability	Δf/f ₂₅	Referenced to +25°C reading		15, 20, 30, 50, 100 or 150		±ppm
Aging	Δf/f ₀	Typical per year @ +25°C	-3	-	3	ppm

Crystal Parameters

PARAMETER	SYMBOL	CONDITIONS	MIN	TYP	MAX	UNIT
Operating Mode	-	-		Fundamental		-
Crystal Cut	-	-		AT-Cut Strip		-
Load Capacitance	C _L	-		See Ordering Information		pF
Shunt Capacitance	C ₀	-	-	-	3.0	pF
Series Resistance						
Fundamental	R ₁	24MHz - <40MHz	-	-	150	Ω
		40MHz - 60MHz	-	-	100	
Drive Level	DL	-	-	10	150	μW
Insulation Resistance	R _i	+100Vdc ±15Vdc	500	-	-	MΩ

Δf/f₀ - Frequency deviation referenced to nominal frequency.

Δf/f₂₅ - Frequency deviation over operating temperature range, referenced to +25°C frequency.

Mechanical Specifications

Package Drawing

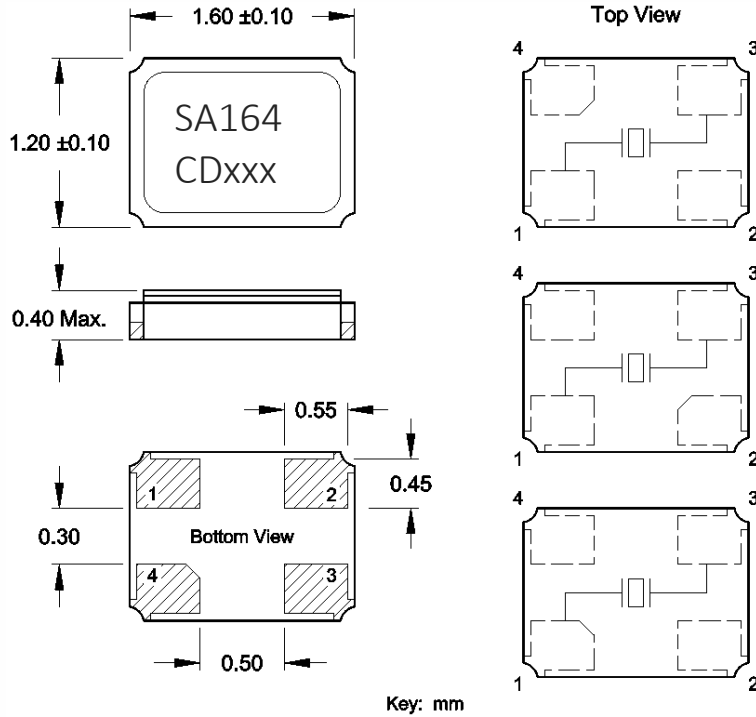

Marking Information

- SA164 – CTS model.
- C – CTS.
- D – Date Code. See Table I for codes.
- xxx – Frequency Code.
3-digits, frequencies below 100MHz
[See document 016-1454-0, Frequency Code Tables.]

Recommended Pad Layout

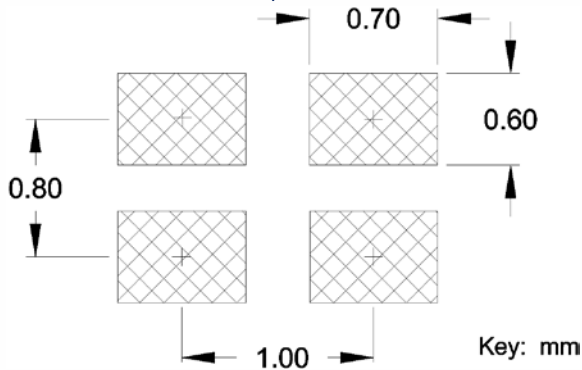

Notes

- JEDEC termination code (e4). Barrier-plating is nickel [Ni] with gold [Au] flash plate.
- Terminations #2, #4 and the metal lid are connected internally. End user may connect these pins to circuit ground for EMI suppression.
- Due to package variability, the pad chamfer on the bottom could be located on Pin 1 in a given lot. Layout orientation should be based on the top view [marking side], as indicated in package drawing. The chamfer location does not affect the electrical performance of the device.
- Reflow conditions per JEDEC J-STD-020; +260°C maximum, 20 seconds.
- MSL = 1.

Table I – Date Code, Beginning year 2021

MONTH					JAN	FEB	MAR	APR	MAY	JUN	JUL	AUG	SEP	OCT	NOV	DEC
YEAR																
2021	2025	2029	2033	2037	A	B	C	D	E	F	G	H	J	K	L	M
2022	2026	2030	2034	2038	N	P	Q	R	S	T	U	V	W	X	Y	Z
2023	2027	2031	2035	2039	a	b	c	d	e	f	g	h	j	k	l	m
2024	2028	2032	2036	2040	n	p	q	r	s	t	u	v	w	x	y	z

Packaging – Tape and Reel

Tape Drawing

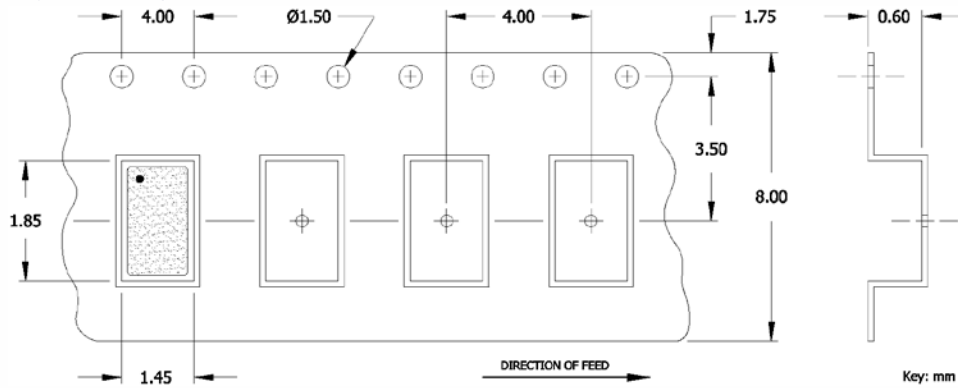

Reel Drawing

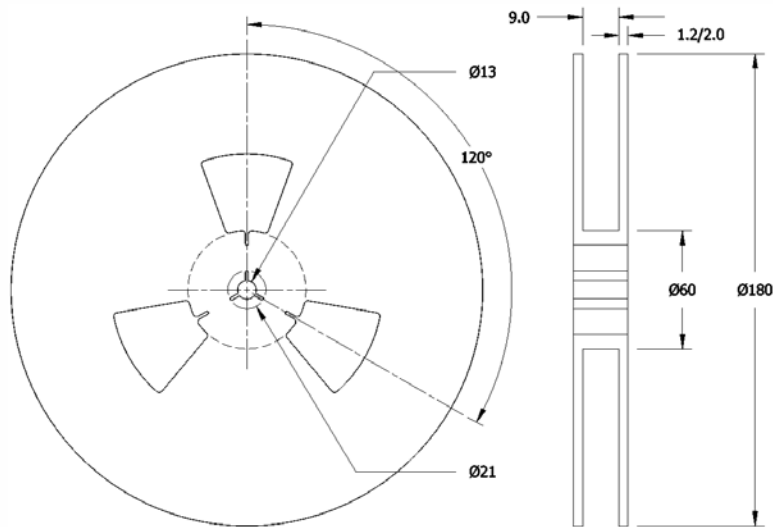

Notes

1. Device quantity is 1k pieces minimum to 3k pieces maximum per 180mm reel.
2. Complete CTS part number, frequency value, date code and manufacturing site code information must appear on reel and carton labels.



Addendum

Common Frequencies and Frequency Codes – MHz

Common Wireless Frequencies		Additional Frequencies					
FREQUENCY	FREQUENCY CODE	FREQUENCY	FREQUENCY CODE	FREQUENCY	FREQUENCY CODE	FREQUENCY	FREQUENCY CODE
24.000000	240	24.305000	243	33.333300	33A		
25.000000	250	24.545400	24F	33.868800	338		
26.000000	260	24.545454	24G	35.328000	353		
27.120000	271	24.553500	24B	36.000000	360		
30.000000	300	24.576000	24C	38.000000	380		
32.000000	320	25.000625	25A	38.880000	388		
37.400000	374	26.041660	26F	39.062500	39A		
38.400000	384	27.000000	270	41.600000	41C		
40.000000	400	28.224000	282	44.000000	440		
48.000000	480	28.322000	28C	45.000000	450		
52.000000	520	28.375000	283	49.152000	491		
		28.636360	286	50.000000	500		
		29.491200	29B	54.000000	540		
		30.400000	304				
		30.720000	307				
		31.250000	312				
		32.768000	327				
		33.000000	330				
		33.330000	333				
		33.333000	33E				