

Features

- Guaranteed 1.8V and 5.5V performance
- Rail-to-Rail Input and Output
- Low supply current 40μA/comparator Typ
- Open-Drain Output for Maximum Flexibility
- RoHS and Halogen free compliance
- package: SOT353(SC70-5),SOT23-5,SOP-8

Applications

- Alarm and Monitoring Circuits
- Peak and Zero-crossing Detectors
- Logic Level Shifting or Translation
- Window Comparators
- IR Receivers
- Portable Systems

General Description

The TECH PUBLIC INCORPORATED LMV331/LMV393 series are low-voltage,(1.8V to 5.5V) single and dual comparators, which are redesigned to effectively reduce cost and space at low-voltage levels.

Pinout (top view)

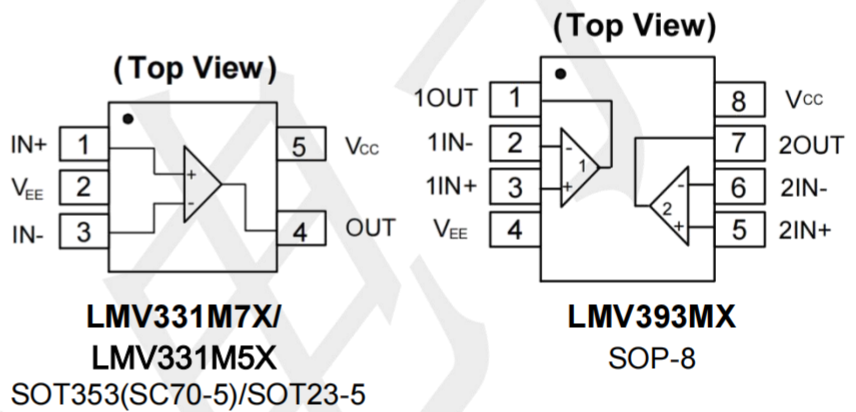

Pin Configurations

LMV331M7X (SOT353) (SC70-5) LMV331M5X (SOT23-5)		
Pin Number	Pin Name	Pin Function
1	IN+	Non-Inverting Input
2	VEE	Chip Supply Voltage(Negative)/GND
3	IN-	Inverting Input
4	OUT	Output
5	VCC	Chip Supply Voltage(Positive)
LMV393MX (SOP-8)		
1	1OUT	Channel 1 Output
2	1IN-	Channel 1 Inverting Input
3	1IN+	Channel 1 Non-inverting Input
4	VEE	Chip Supply Voltage(Negative)/GND
5	2IN+	Channel 2 Non-inverting Input
6	2IN-	Channel 2 Inverting Input
7	2OUT	Channel 2 Output
8	VCC	Chip Supply Voltage(Positive)

Absolute Maximum Ratings

(@TA = +25°C, unless otherwise specified.)

		Rating	UNIT
VID	Differential Input Voltage	±Supply Voltage	V
VCC -VEE	Supply Voltage	5.5	V
θJA	Thermal Resistance	SOT353(SC70-5)	333
	Junction-to Ambient	SOT23-5	190
		SOP-8	125
LT	Lead Temperature (Soldering, 10 sec.)	260	
Temperature	Junction Temperature , TJ	-40	125
	Storage, Tstg	-65	150
HBM	ESD Susceptibility	4000	V
MM		300	

BLOCK DIAGRAM

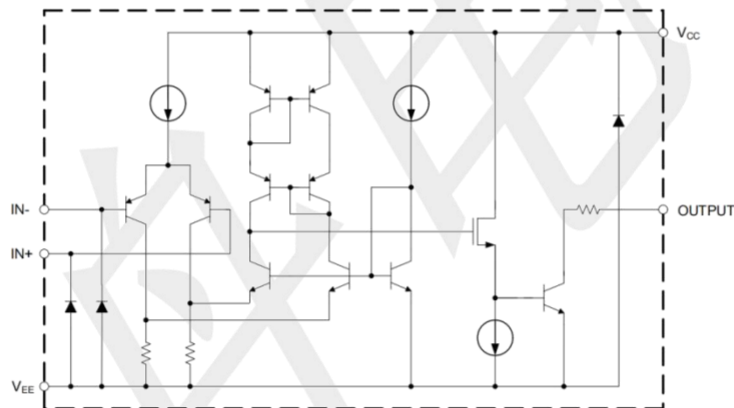

Power Supply Bypassing

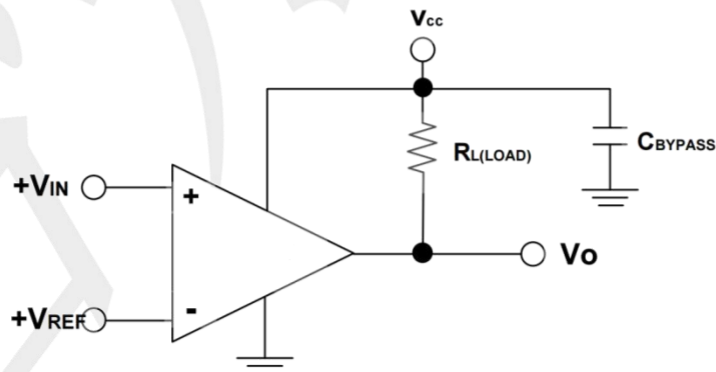

For better performance, power supply bypass capacitor is necessary. For a single-supply operation system, a minimum of 0.1μF bypass capacitor should be recommended to place as close as possible between VCC pin and GND.

Typical Application Circuit

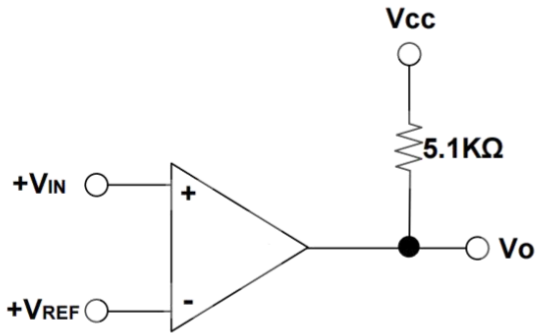

Basic Comparator

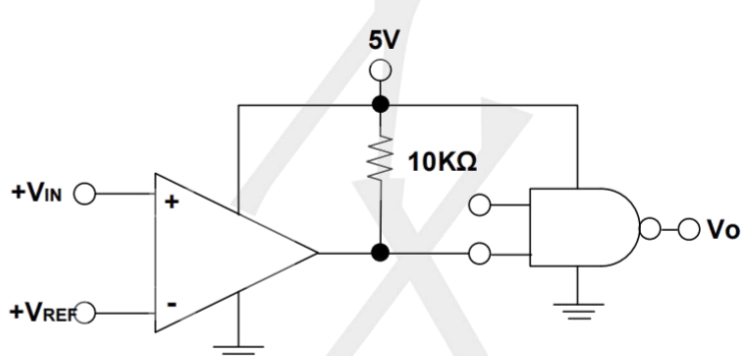

Driving CMOS/TTL

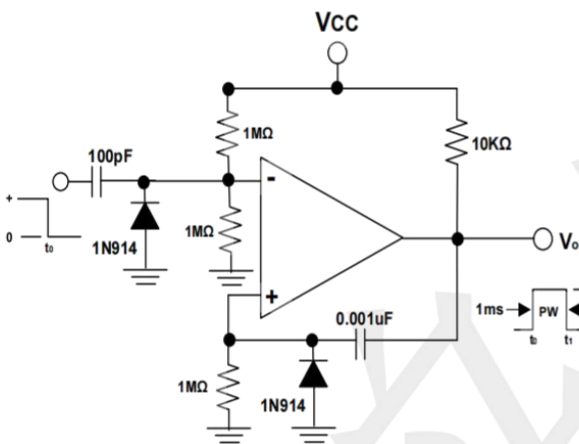

One-Shot Multivibrator

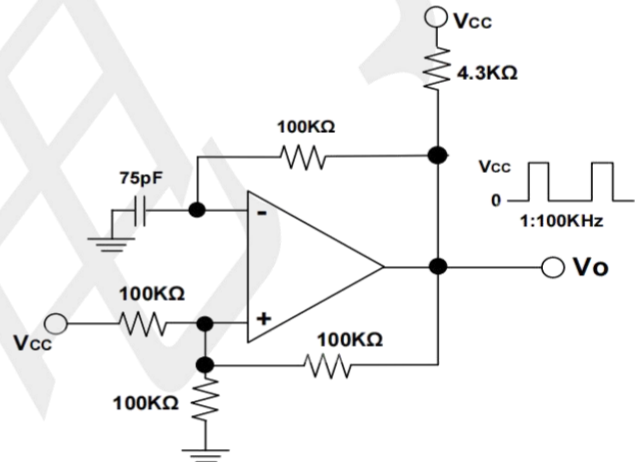

Squarewave Oscillator

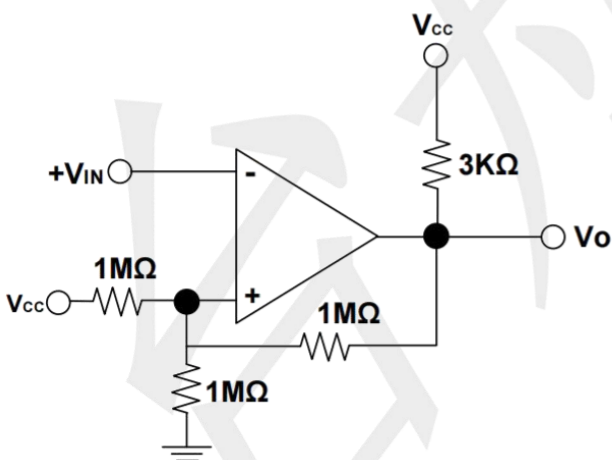

Inverting Comparator with Hysteresis

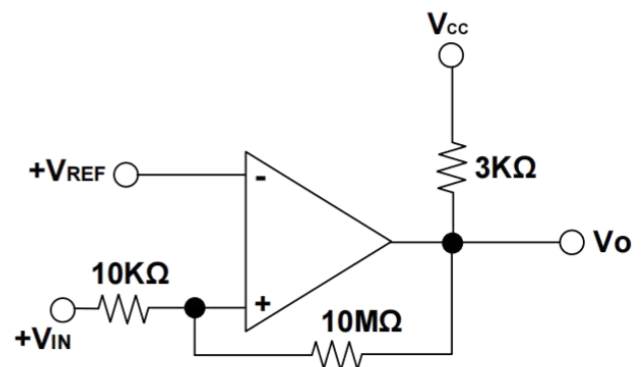

Non-Inverting Comparator with Hysteresis

Electrical Characteristics

(At $V_S = +5V$, $V_{CM} = 0V$, $C_L = 15pF$, and $T_A = +25^\circ C$, unless otherwise noted.)

PARAMETER	SYMBOL	TEST Conditions	MIN	TYP	MAX	UNIT
Operating Voltage Range	V_{CC}		1.8	--	5.5	V
Quiescent Current / Comparator	I_Q		--	40	70	μA
Input Offset Voltage	V_{OS}		--	0.5	3	mV
Input Offset Voltage Tempco	$\Delta V_{OS}/\Delta T$		--	2	--	$\mu V/^\circ C$
Input Bias Current	I_B		--	6	--	PA
Input Offset Current	I_{OS}		--	4	--	PA
Common-Mode Voltage Range	V_{CM}	$V_S = 5.5V$	--	-0.1 to +5.6	--	V
Common-Mode Rejection Ratio	CMRR	$V_S = 5V, V_{CM} = 0V$ to 5V	--	70	--	dB
Power-Supply Rejection Ratio	PSRR	$V_S = +1.6V$ to +5.5V, $V_{CM} = 0V$	--	75	--	dB
Input Hysteresis	V_{HYS}		--	6	--	mV
Output Voltage Swing from Rail	V_{OH}	$V_S = 5V, I_O = 1mA$	--	$V_S - 0.05$	$V_S - 0.3$	V
	V_{OL}		--	57	300	V
Output Short-Circuit Current	I_{SINK}	$V_S = 5V, Out$ to $V_S/2$	--	33	--	mA
Propagation Delay (Low to High)	T_{dLH}	$V_S = 3V, Overdrive = 100mV$	--	77.5	--	ns
Propagation Delay (High to Low)	T_{dHL}		--	59.4	--	ns
Rise Time	T_r		--	5	--	ns
Fall Time	T_f		--	5	--	ns

Notes:

1. Typical values represent the most likely parametric norm as determined at the time of characterization. Actual typical values may vary over time and will also depend on the application and configuration. The typical values are not tested and are not guaranteed on shipped production material.
2. All limits are guaranteed by testing or statistical analysis.

Typical Performance Characteristics (@TA = +25°C, unless otherwise specified.)

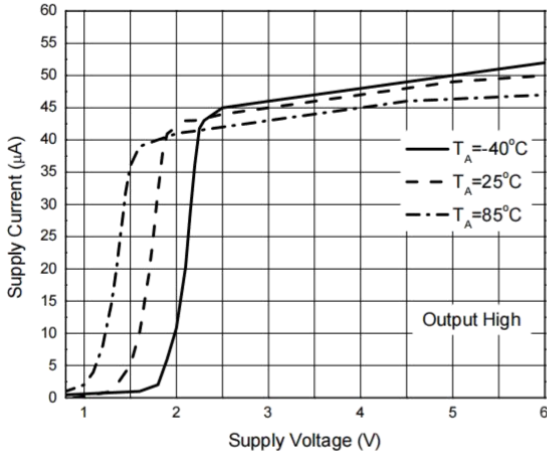

Supply Current vs. Supply Voltage (TPV331)

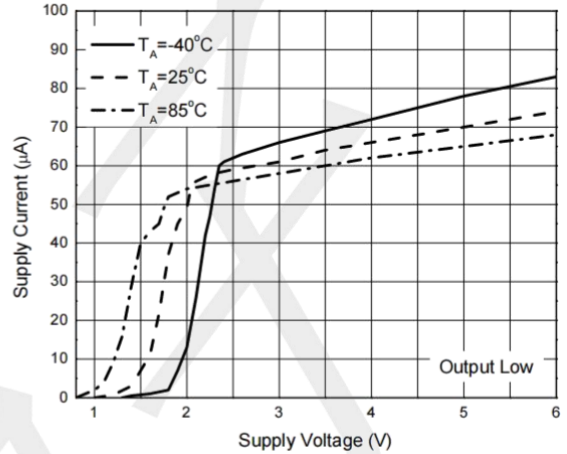

Supply Current vs. Supply Voltage (TPV331)

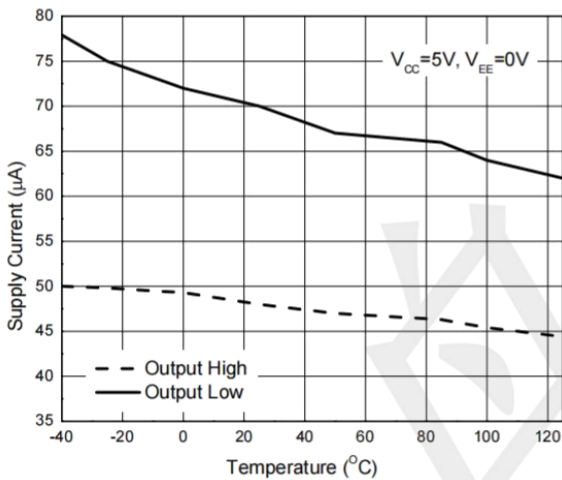

Supply Current vs. Temperature (TPV331)

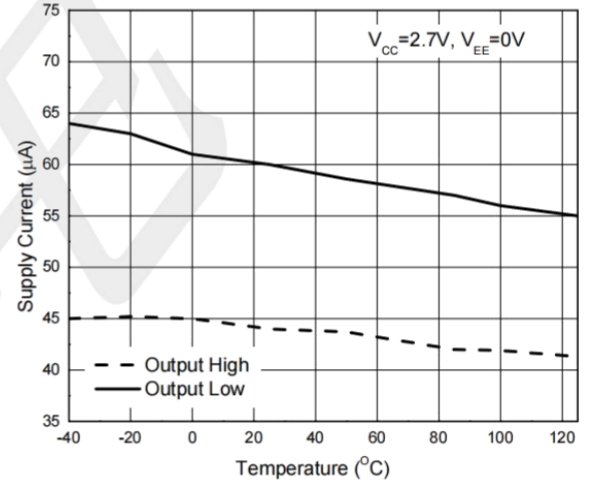

Supply Current vs. Temperature (TPV331)

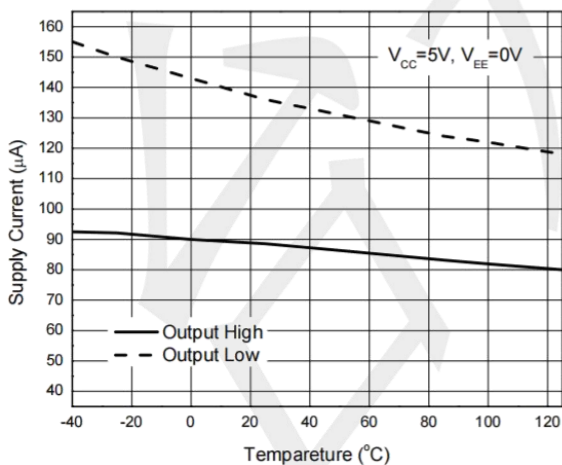

Supply Current vs. Temperature (TPV393)

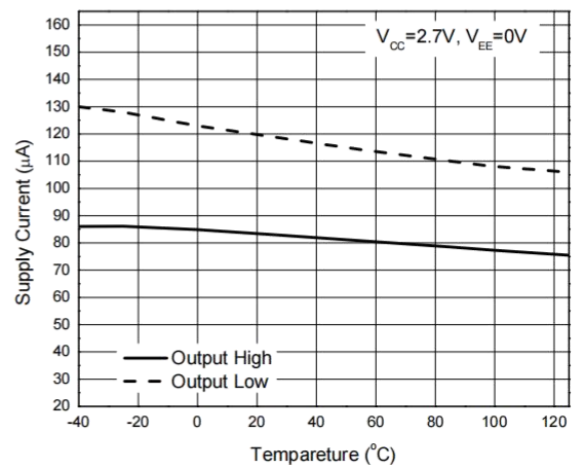

Supply Current vs. Temperature (TPV393)

Package information

SOT23-5

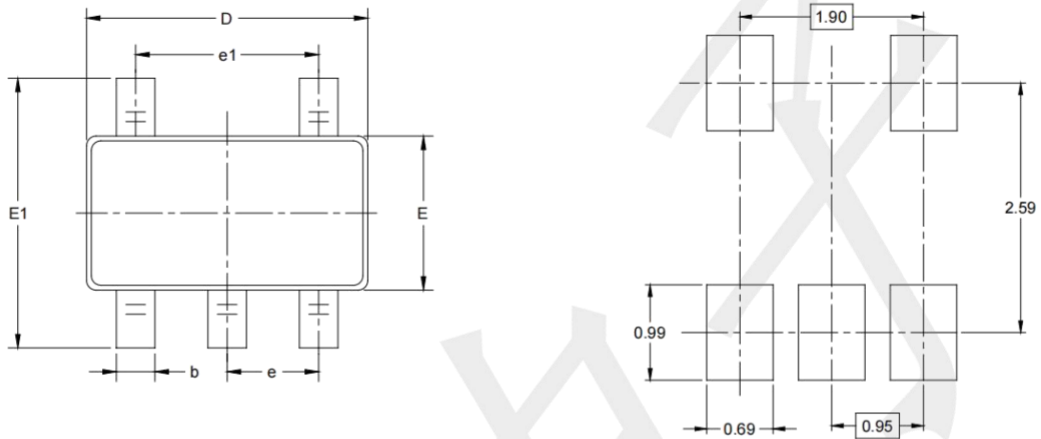

RECOMMENDED LAND PATTERN (Unit: mm)

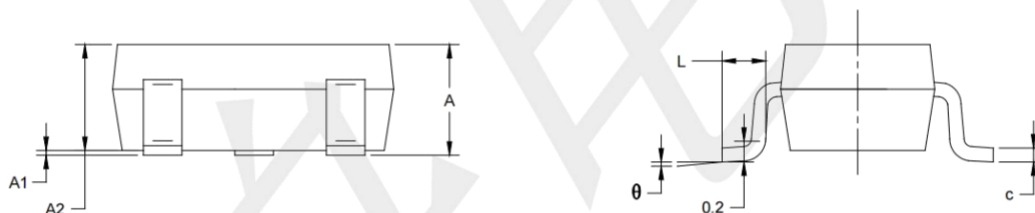

Symbol	Dimensions In Millimeters		Dimensions In Inches	
	MIN	MAX	MIN	MAX
A	1.050	1.250	0.041	0.049
A1	0.000	0.100	0.000	0.004
A2	1.050	1.150	0.041	0.045
b	0.300	0.500	0.012	0.020
c	0.100	0.200	0.004	0.008
D	2.820	3.020	0.111	0.119
E	1.500	1.700	0.059	0.067
E1	2.650	2.950	0.104	0.116
e	0.950 BSC		0.037 BSC	
e1	1.900 BSC		0.075 BSC	
L	0.300	0.600	0.012	0.024
θ	0°	8°	0°	8°

Package information

SOT353(SC70-5)

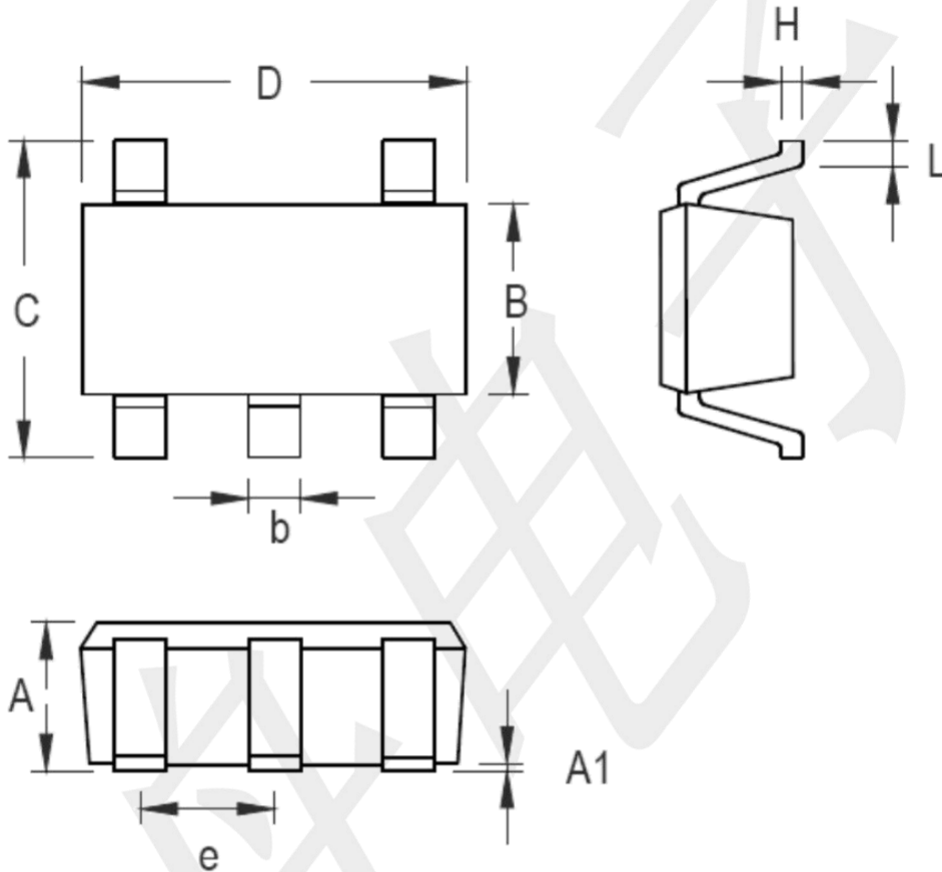

Symbol	Dimensions In Millimeters		Dimensions In Inches	
	Min	Max	Min	Max
A	0.800	1.100	0.031	0.044
A1	0.000	0.100	0.000	0.004
B	1.150	1.350	0.045	0.054
b	0.150	0.400	0.006	0.016
C	1.800	2.450	0.071	0.096
D	1.800	2.250	0.071	0.089
e	0.650		0.026	
H	0.080	0.260	0.003	0.010
L	0.210	0.460	0.008	0.018

Package information

SOP-8

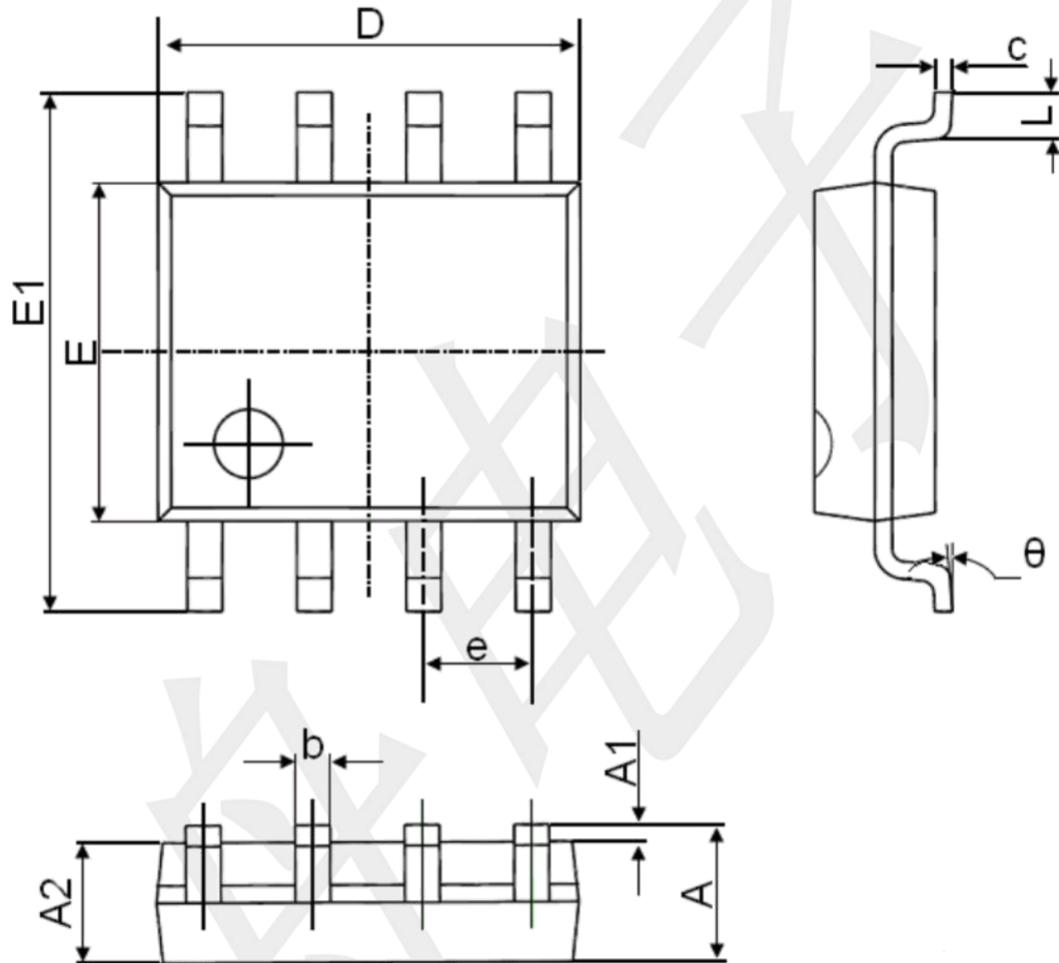

Symbol	Dimensions In Millimeters		Dimensions In Inches	
	Min.	Max.	Min.	Max.
A	1.350	1.750	0.053	0.069
A1	0.100	0.250	0.004	0.010
A2	1.350	1.550	0.053	0.061
b	0.330	0.510	0.013	0.020
c	0.170	0.250	0.006	0.010
D	4.700	5.100	0.185	0.200
E	3.800	4.000	0.150	0.157
E1	5.800	6.200	0.228	0.244
e	1.270(BSC)		0.050(BSC)	
L	0.400	1.270	0.016	0.050
θ	0°	8°	0°	8°