

Features

- Typical Quiescent Current of 3 μ A
- No External Components
- V_{CC} Transient Immunity
- Correct Logic Output Guaranteed to V_{CC}=1.0V
- Push-Pull Low Active Reset Output
- Packages SOT23

Applications

- Computers
- Embedded Systems
- Battery-Powered Equipments
- Intelligent Instruments
- CPU and Logic Circuit Reset
- Power Fail Detectors
- Automotive

Pin Definition

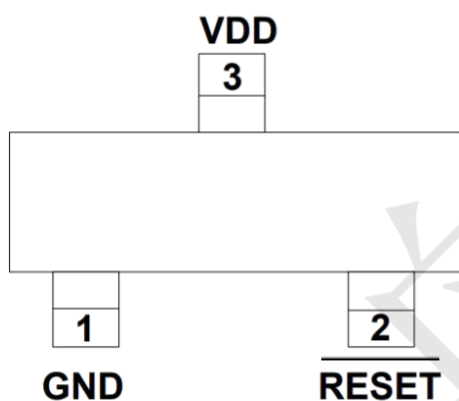

Ordering Information

ORDER NUMBER	RESET VOLTAGE
TPTLV809L30DBZR-TP	2.63V
TPTLV809K33DBZR-TP	2.93V

PIN CONFIGURATION

PIN	NAME	FUNCTION
1	GND	Ground
2	RESET	RESET output remains low while VCC is below the reset voltage threshold, and for a reset timeout period after VCC rises above reset threshold
3	VCC	Supply Voltage .

Absolute Maximum Ratings (Note 1)

Symbol	Parameter	Value	UNIT
VCC	Any pin with respect to ground	-0.3 to +6.0	V
ICC	Input Current, VCC	20	mA
IO	Output Current, RESET	20	mA
	Rate of Rise, VCC	100	V/ μ s
PD	Continuous Power Dissipation	250	mW
TA	Operating Temperature Range	-40 to +85	$^{\circ}$ C
TSTG	Storage Temperature Range	-65 to +105	$^{\circ}$ C
R $^{\theta}$ JC	Thermal Resistance from Junction to Case	110	$^{\circ}$ C/W
R $^{\theta}$ JA	Thermal Resistance from Junction to Ambient	250	$^{\circ}$ C/W

TYPICAL APPLICATION CIRCUIT

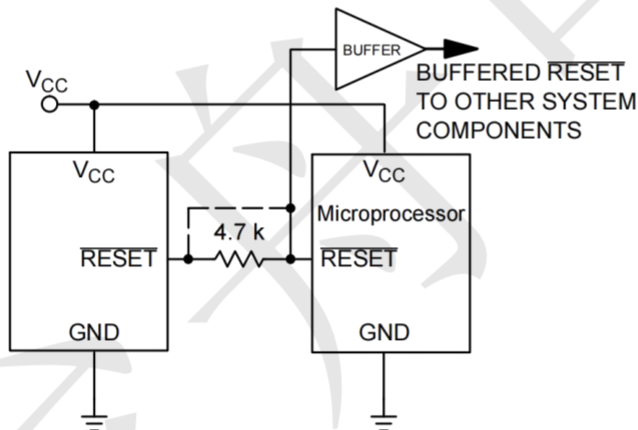

FUNCTIONAL BLOCK DIAGRAM

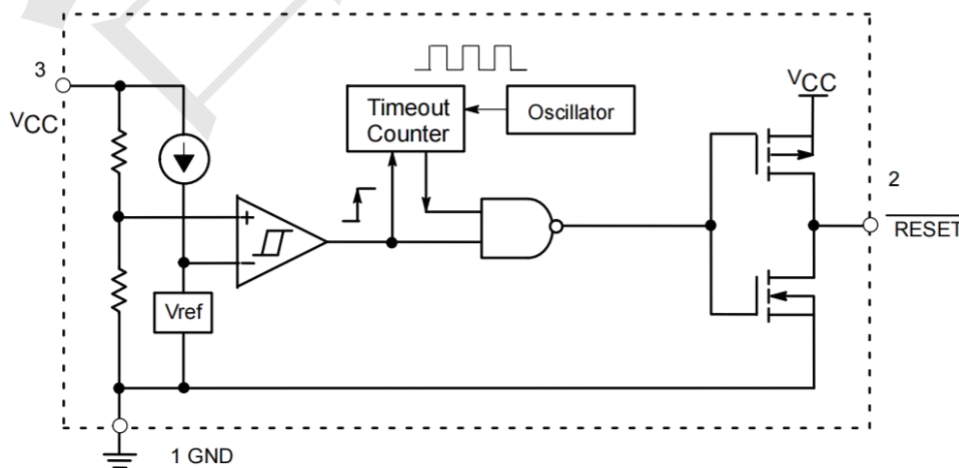

Series Complementary Active-Low Output

Electrical Characteristics

Symbol	Parameter	Conditions	Min	Typ	Max	Unit	
	V _{CC} Range	T _A =0°C to +70°C	1.0		5.5	V	
I _{CC}	Supply Current	V _{CC} <5.5V,		3	5	μA	
		V _{CC} <3.6V,		3	5		
V _{TH}	Reset Threshold	K33	T _A =+25°C	2.83	2.93	2.97	V
			T _A =-40°C to +85°C	2.80		3.00	
		L30	T _A =+25°C	2.54	2.63	2.67	
			T _A =-40°C to +85°C	2.51		2.69	
Reset Threshold Tempco				30		ppm/°C	
V _{CC} to Reset Delay		V _{CC} =V _{TH} to (V _{TH} -100mV)		10		μs	
Reset Active Timeout Period		T _A =-40°C to +85°C	140	240	360	ms	
V _{OL}	RESET Output Voltage Low (Push-Pull Active Low)	V _{CC} =V _{TH} min, I _{SINK} =1.2mA, S/T/Z			0.3	V	
		V _{CC} =V _{TH} min, I _{SINK} =3.2mA, J/L/M			0.4		
		V _{CC} ≤1.0V, I _{SINK} =50μA			0.3		
V _{OH}	RESET Output Voltage High (Push-Pull Active Low)	V _{CC} >V _{TH} max, I _{SOURCE} =500μA, S/T/Z	0.8V _{CC}			V	
		V _{CC} >V _{TH} max, I _{SOURCE} =800μA, J/L/M	V _{CC} -1.5				

Note 1: Production testing done at T_A=+25°C; limits over temperature guaranteed by design only.

Typical Operating Characteristics

(VCC = Full range, TA = -40°C to +85°C unless otherwise noted. Typical values at TA = +25°C and VCC = 5 V for the L/M/J versions, VCC = 3.3 V for the T/S versions, VCC = 3 V for the R version and VCC = 2.5 V for the Z version.)

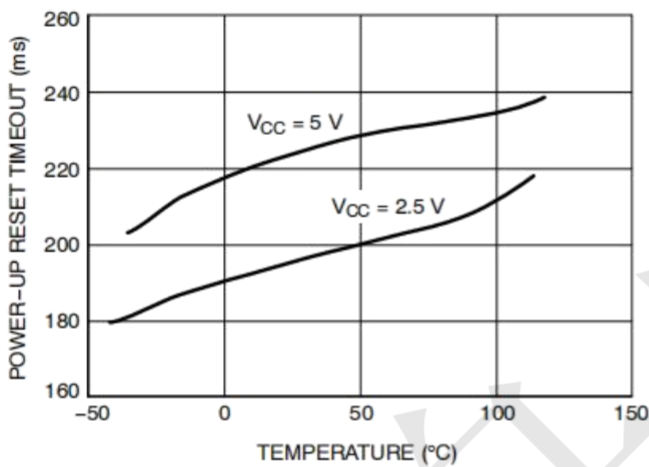

Power-Up Reset Timeout vs. Temperature

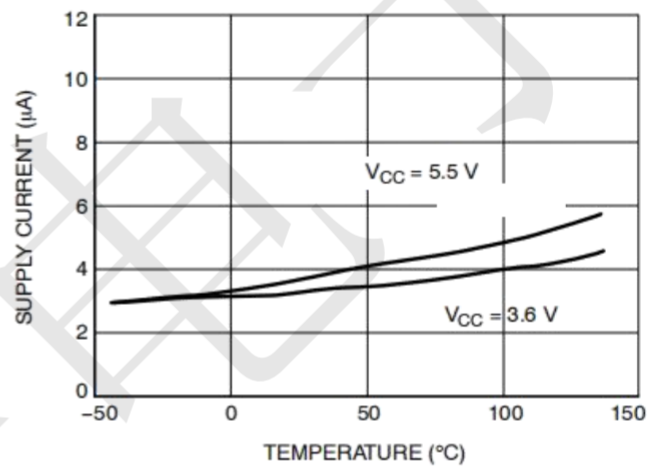

Supply Current vs. Temperature (No Load,)

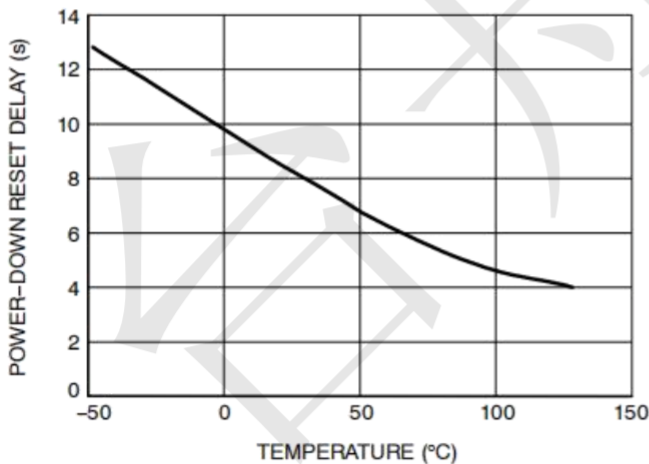

Power-Down Reset Delay vs. Temperature

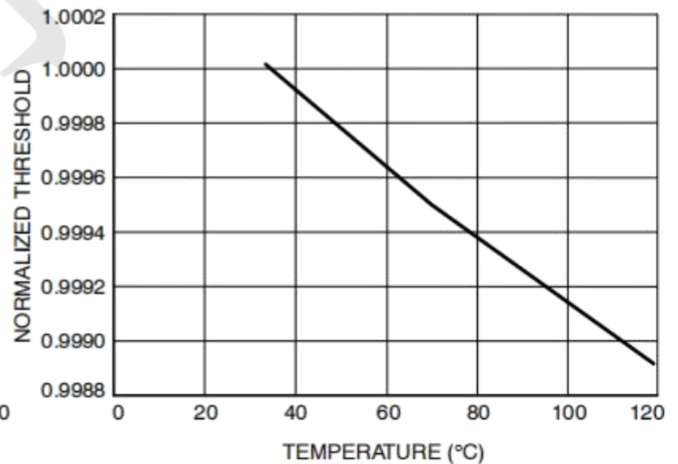

Normalized Reset Threshold vs. Temperature

Package Outline Dimensions (unit: mm)

SOT23

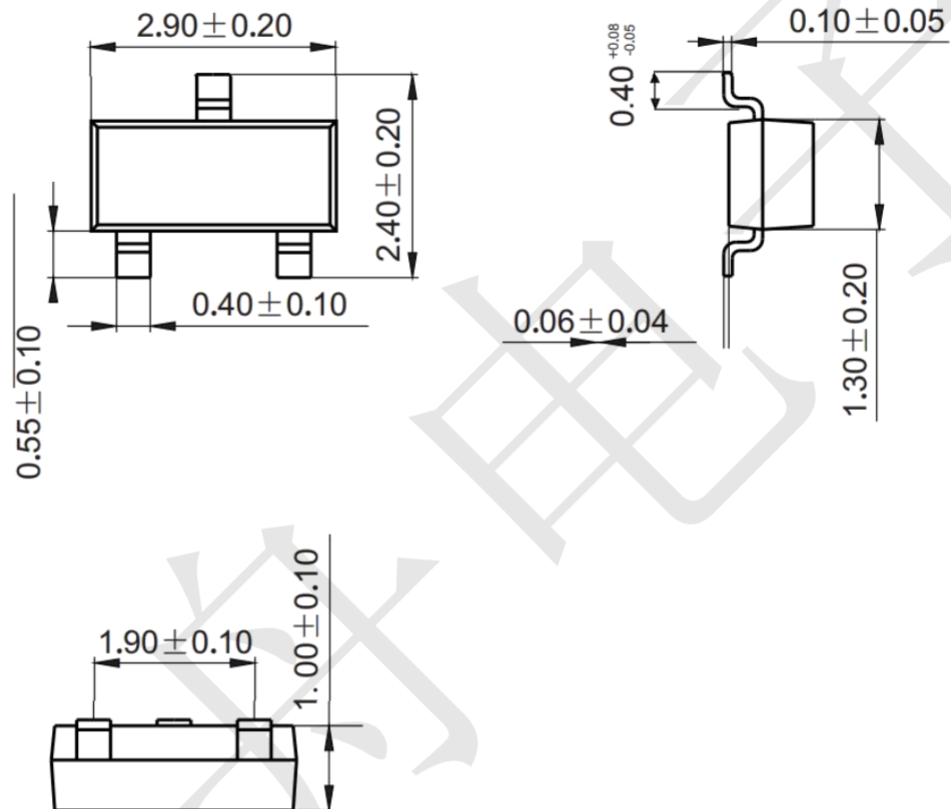

Mounting Pad Layout (unit: mm)

