

修订	标记	修改摘要	签名	日期
REV	MARK	REVISION DESCRIPTION	SIGNATURE	DATE
AO		NEW DWG		2016-03-12

NOTE:

- MATERIAL SPECIFICATION:
 - HOUSING: HIGH TEMPERATURE RESISTANT PLASTIC, UL94 V-0.
 - CONTACTS: COPPER ALLOY
 - MID PLATE: STAINLESS STEEL
 - SHELL: STAINLESS STEEL
- PLATING SPECIFICATION:
 - CONTACTS:
 - Ni 50u" MIN. UNDER PLATED OVER ALL.
 - Au PLATED ON THE FUNCTIONAL AREA OF CONTACT. (GOLD PLATING THICKNESS FOLLOW THE P/N)
 - GOLD FLASH PLATING ON SOLDER AREA
 - SHELL OR OUTSIDE SHELL:
 - Ni 30u" MIN. UNDER PLATED OVER ALL.
- MECHANICAL PERFORMANCE,
 - INSERTION FORCE: 0.5~2.0kgf.
 - REMOVAL FORCE: 0.8kgf~2.0kgf.
 - DURABILITY: 10000 CYCLES.
- ELECTRICAL PERFORMANCE,
 - CURRENT RATING: 5A
VOLTAGE RATING: 20V
 - INSULATION RESISTANCE: 100MΩ MIN
 - DIELECTRIC WITHSTAND VOLTAGE, AC 100V FOR 1 MINUTE.
 - LOW CONTACT RESISTANCE: INITIAL 40MΩ
AFTER 50MΩ
- ENVIRONMENTAL PERFORMANCE:
 - OPERATING TEMPERATURE: -30°C~+80°C.
- IR REFLOW:
 - THE PEAK TEMPERATURE ON THE BOARD SHALL BE MAINTAINED FOR 10 SECONDS AT 260°C.

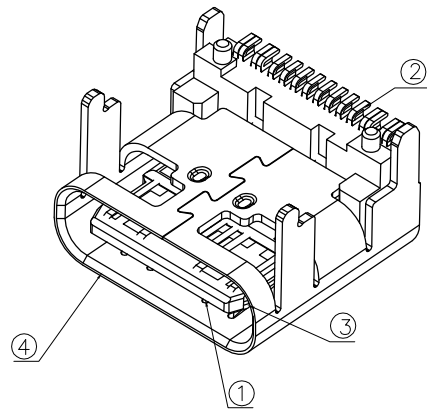
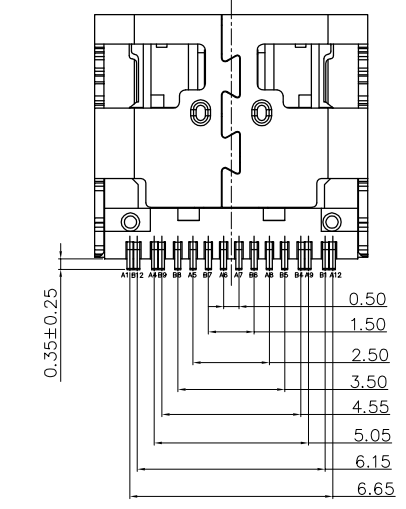
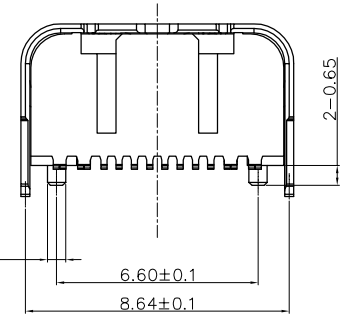
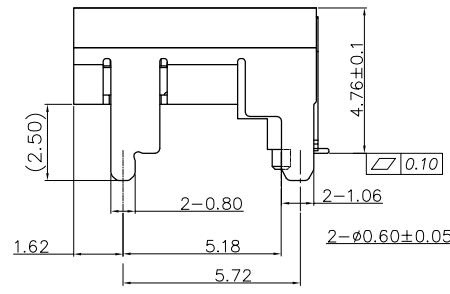
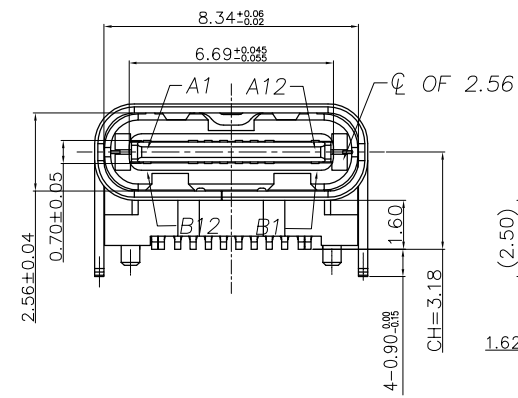
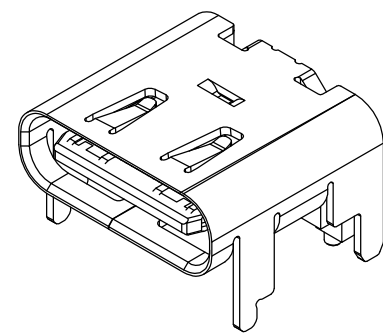
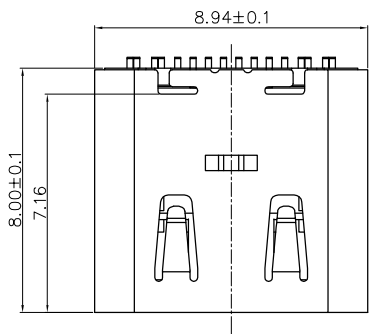

4	SHELL	STAINLESS STEEL T=0.30MM	NI 40u"MIN	1PCS
3	SHIELDING PLATE	STAINLESS STEEL T=0.15MM	N/A	1PCS
2	CONTACT	COPPER ALLOY T=0.15MM	Mating area 1u"Au Solder Tails: G/F Underplate: 80u"Min Ni overall	2SET
1	INSERT MOLDING	LCP UL94V-0	BLACK	1PCS
NO.	DESCRIPTION	MATERIAL	REMARKS	



深圳市华德共创科技有限公司
Shenzhen Huade co-create Technology Co.,LTD
电话: 0755-27111216 传真: 0755-29940187

-TOLERANCES- UNLESS OTHERWISE SPECIFIED 公差参数表			TITLE: TYPE C 16PIN 板上型垫高1.6 产品名称: 带弹 L=8.0					
X.X	±0.30	X.X*	±3°	APPD: 核准:	PART NO: 产品编号: TYPE C-DB-117PWB			
X.XX	±0.20	X.XX*	±2°	CHECK: 校对: 王建业	DATE	SCALE	UNIT	CODE NUMBER
X.XXX	±0.10	X.XXX*	±1°	DRAW: 绘图: 黄艳兰	2016-03-12	1:1	mm	A001

修订 REV A0	标记 MARK	修改摘要 REVISION DESCRIPTION NEW DWG	签名 SIGNATURE	日期 DATE 2016-03-12
-----------------	------------	---	-----------------	--------------------------

USB TYPE-C PIN ASSIGNMENTS

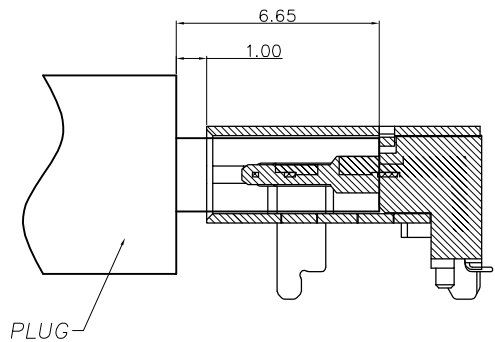

PIN NUMBER	SIGNAL NAME	PIN NUMBER	SIGNAL NAME
A1	GND	B12	GND
A4	VBUS	B9	VBUS
A5	CC1	B8	SBU2
A6	Dp1	B7	Dn2
A7	Dn1	B6	Dp2
A8	SBU1	B5	CC2
A9	VBUS	B4	VBUS
A12	GND	B1	GND

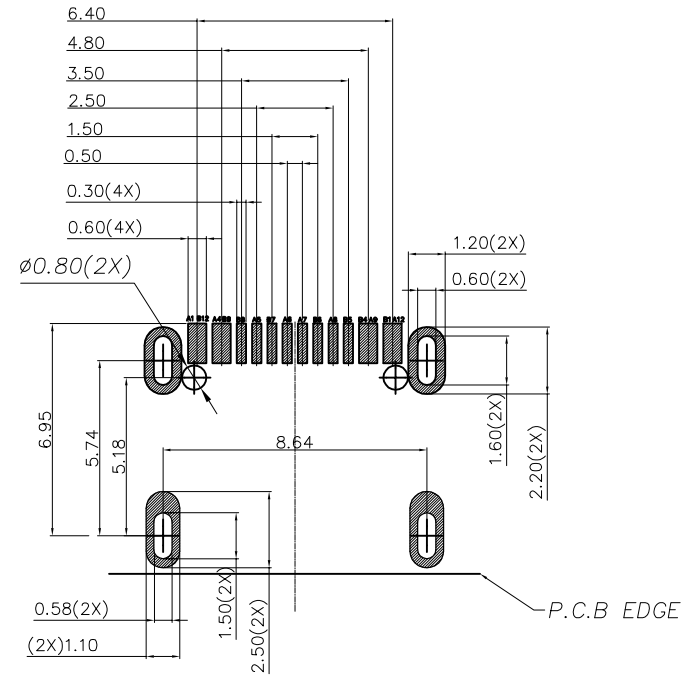

AFTER MATING
SCALE 1:1



RECOMMEND P.C.B LAYOUT(COMPONENT SIDE)
TOLERANCE FOR PCB LAYOUT IS ± 0.05

		深圳市华德共创科技有限公司 Shenzhen Huade co-create Technology Co.,LTD 电话：0755-27111216 传真：0755-29940187						
		TITLE: TYPE C 16PIN 板上型垫高1.6 产品名称: 带弹 L=8.0		PART NO: 产品编号: TYPE C-DB-117PWB				
-TOLERANCES- UNLESS OTHERWISE SPECIFIED 公差参数表		 		DATE	SCALE	UNIT	CODE NUMBER	
X.X	± 0.30	X.X*	$\pm 3^\circ$	APPD: 核准:	DATE	SCALE	UNIT	CODE NUMBER
X.XX	± 0.20	X.XX*	$\pm 2^\circ$	CHECK: 校对: 王建业	2016-03-12	1:1	mm	A001
X.XXX	± 0.10	X.XXX*	$\pm 1^\circ$	DRAW: 绘图: 黄艳兰				

修訂 REV A0	标记 MARK	修改摘要 REVISION DESCRIPTION	签名 SIGNATURE	日期 DATE
		NEW DWG		2016-03-12

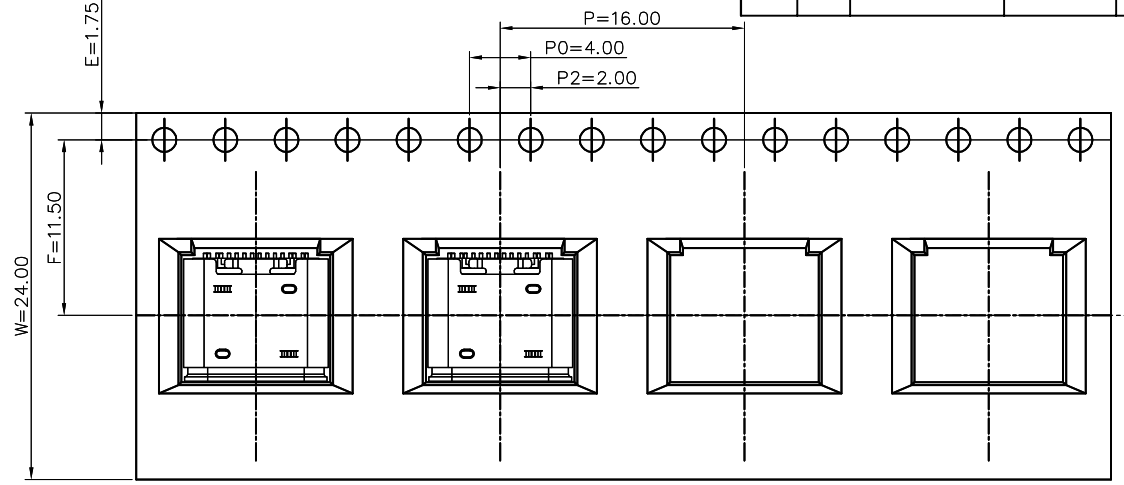
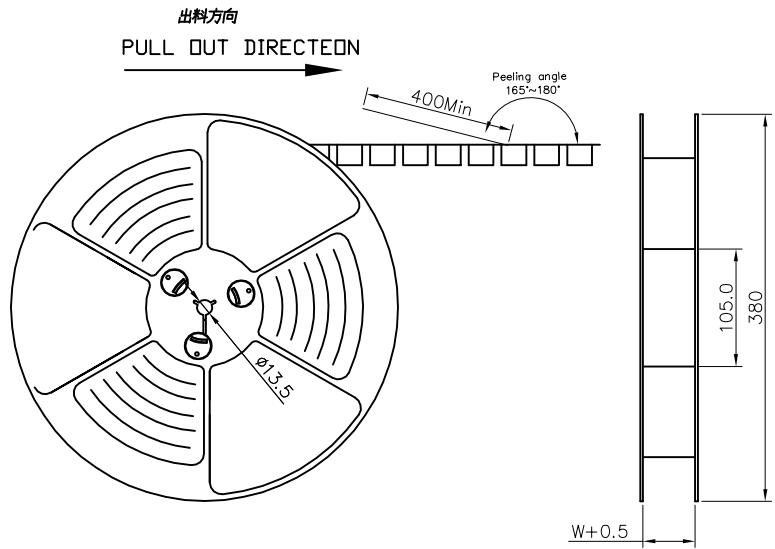

NOTES

1. 帶子引導長度
LEAD TAPE LENGTH

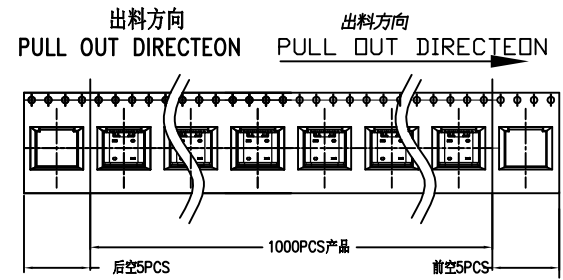

2. 上帶 剝離力為: 0.1~1.3N(10.2gf~130gf)
PEELING OFF FORCE OF TOP TAPE: 0.1~1.3N(10.2gf~130gf)
出貨運輸過程中一定注意:
THIS REQUIREMENT SHOULD BE APPLIED AT SHIPMENT:
卷帶在運輸過程中不能散開
PEELING OFF SHOULD NOT BE ALLOWED DURING TRANSPORTATION

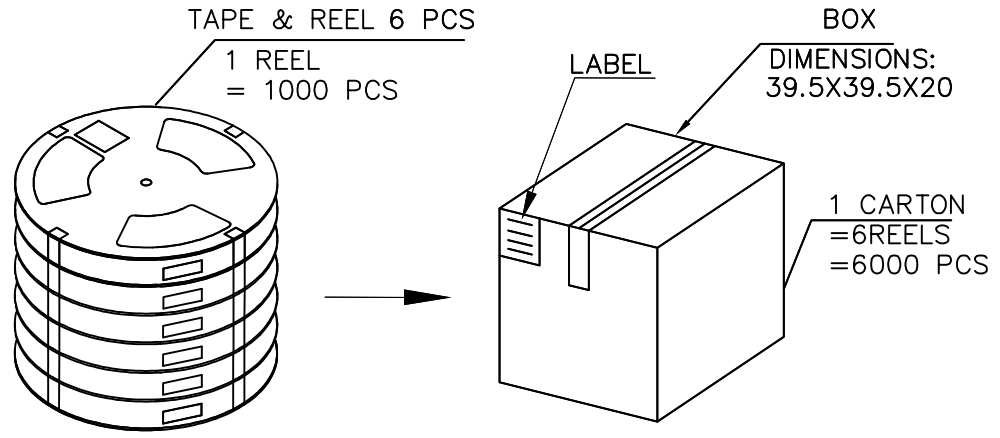

包裝明細表 (The detail of the packing) Carton						
產品料號 (Product No.)	包裝容量 (Packing Capacity)			重量 Weight (Kg)		
	pcs/box	boxes/Carton	Pcs/Box	N.W./Pcs	N.W./Box	G.W./Box
UCR04-0161X-00XR	1000	6	6000	----	----	----

		深圳市華德共創科技有限公司 Shenzhen Huade co-create Technology Co.,LTD 電話: 0755-27111216 傳真: 0755-29940187			
-TOLERANCES- UNLESS OTHERWISE SPECIFIED 公差參數表				TITLE: TYPE C 16PIN 板上型墊高1.6 產品名稱: 帶彈 L=8.0	
X.X	±0.30	X.X*	±3*	APPD: 核准:	PART NO: 產品編號: TYPE C-DB-117PWB
X.XX	±0.20	X.XX*	±2*	CHECK: 校對: 王建業	DATE SCALE UNIT CODE NUMBER
X.XXX	±0.10	X.XXX*	±1*	DRAW: 繪圖: 黃艷蘭	2016-03-12 1:1 mm A001