

1

2

3

4

A

A

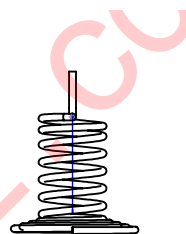
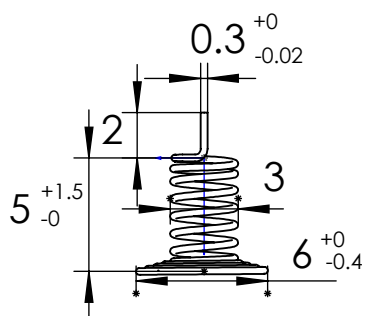

B

B

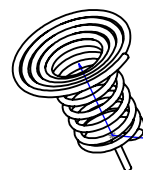
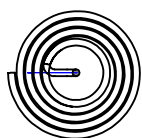

C

C

Technical requirements:

- 1、Unit: mm
- 2、Wire diameter: 0.3
- 3、Material: Nickel-plated carbon steel (RoHS compliant)
- 4、Type: horn mouth center
- 5、Processing: Heat-treated at 260° C
- 6、Size tolerance: ± 0.25 for unmarked dimensions
- 7、Quality: Free from surface contaminants, No base material defects
- 8、Contact number: 13459252012、0592-5216722
- 9、Mode: F6-5-3-0.3Z
- 10、Salt spray test: passes 24 Hours test (5% NaCl Solution)
- 11、Package: Bag-packed, MPQ: 2000PCS/bag

D

D

E

E

						碳钢线			厦门市芯网电子科技有限公司	
						阶段标记	重量	比例		
标记	处数	分区	更改文件号	签名	年月日					
设计						s		3:1		
校核										
批准										

F

F

1

2

3

4