



CD4023 (LX) Triple 3-input Nand Gate

Product Specification

Specification Revision History:

Version	Date	Description
2019-06-A1	2019-06	New
2023-04-B1	2023-04	Update the template



灵星芯微 芯片经营

Contents

1、 General Description.....	3
2、 Block Diagram And Pin Description	5
2.1、 Block Diagram	5
2.2、 Pin Configurations.....	5
2.3、 Pin Description	6
2.4、 Function Table.....	6
3、 Electrical Parameter	6
3.1、 Absolute Maximum Ratings.....	6
3.2、 Recommended Operating Conditions	7
3.3、 Electrical Characteristics	7
3.3.1、 DC Characteristics 1	7
3.3.2、 DC Characteristics 2	8
3.3.3、 AC Characteristics	8
4、 Testing Circuit	9
4.1、 AC Testing Circuit	9
4.2、 AC Testing Waveforms.....	9
4.3、 Measurement Points	9
4.4、 Test Data	9
5、 Package Information	10
5.1、 DIP14	10
5.2、 SOP14	11
5.3、 TSSOP14.....	12
6、 Statements And Notes	13
6.1、 The name and content of Hazardous substances or Elements in the product.....	13
6.2、 Notes	13



灵星芯微 集成电路

1、General Description

The CD4023 provides the positive triple 3-input NAND function. The outputs are fully buffered for highest noise immunity and pattern insensitivity of output impedance.

It operates over a recommended V_{DD} power supply range of 3V to 15V referenced to GND (usually ground). Unused inputs must be connected to V_{DD} , GND, or another input.

Features:

- Wide supply voltage range from 3V to 15V
- Fully static operation
- 5V, 10V, and 15V parametric ratings
- Standardized symmetrical output characteristics
- Inputs and outputs are protected against electrostatic effects
- Specified from -40°C to $+125^{\circ}\text{C}$
- Packaging information: DIP14/SOP14/TSSOP14



Ordering Information:

Tube packing specifications:

Part number	Packaging form	Marking code	Tube quantity	Boxed tube quantity	Boxed quantity	Notes
CD4023BE (LX)	DIP14	CD4023BE	25 PCS/tube	40 tube/box	1000 PCS/box	Dimensions of plastic enclosure: 19.0mm×6.4mm Pin spacing: 2.54mm
CD4023BM(LX)	SOP14	CD4023BM	50 PCS/tube	200 tube/box	10000 PCS/box	Dimensions of plastic enclosure: 8.7mm×3.9mm Pin spacing: 1.27mm
CD4023BPW(LX)	TSSOP14	CD4023	96 PCS/tube	200 tube/box	19200 PCS/box	Dimensions of plastic enclosure: 5.0mm×4.4mm Pin spacing: 0.65mm

Reel packing specifications:

Part number	Packaging form	Marking code	Reel quantity	Boxed reel quantity	Notes
CD4023BM(LX)	SOP14(1)	CD4023BM	2500 PCS/reel	5000 PCS/box	Dimensions of plastic enclosure: 8.7mm×3.9mm Pin spacing: 1.27mm
CD4023BM(LX)	SOP14(2)	CD4023BM	4000 PCS/reel	8000 PCS/box	Dimensions of plastic enclosure: 8.7mm×3.9mm Pin spacing: 1.27mm
CD4023BPW(LX)	TSSOP14	CD4023	5000 PCS/reel	10000 PCS/box	Dimensions of plastic enclosure: 5.0mm×4.4mm Pin spacing: 0.65mm

Note: If the physical information is inconsistent with the ordering information, please refer to the actual product.



2、Block Diagram And Pin Description

2.1、Block Diagram

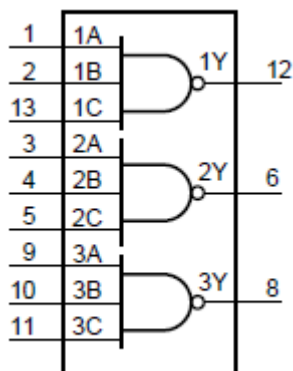

Figure 1. Functional diagram

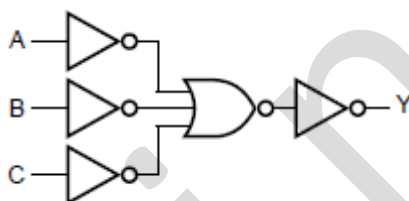
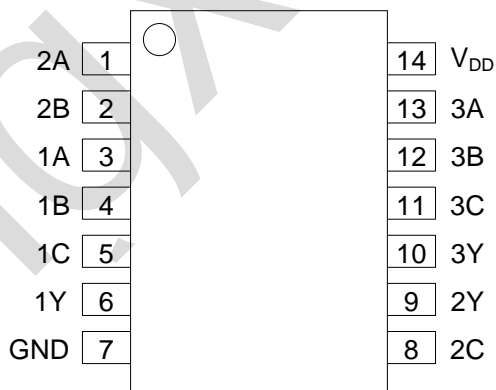

Figure 2. Logic diagram (one gate)

2.2、Pin Configurations





2.3、Pin Description

Pin No.	Pin Name	Description
1	2A	data input
2	2B	data input
3	1A	data input
4	1B	data input
5	1C	data input
6	1Y	data output
7	GND	ground (0V)
8	2C	data input
9	2Y	data output
10	3Y	data output
11	3C	data input
12	3B	data input
13	3A	data input
14	V _{DD}	supply voltage

2.4、Function Table

Input			Output
nA	nB	nC	nY
L	X	X	H
X	L	X	H
X	X	L	H
H	H	H	L

Note: H=HIGH voltage level; L=LOW voltage level; X=don't care.

3、Electrical Parameter

3.1、Absolute Maximum Ratings

(Voltages are referenced to GND (ground=0V), unless otherwise specified.)

Parameter	Symbol	Conditions	Min.	Max.	Unit
supply voltage	V _{DD}	-	-0.5	+18	V
DC input current	I _{IK}	any one input	-	±10	mA
input voltage	V _I	all inputs	-0.5	V _{DD} +0.5	V
storage temperature	T _{stg}	-	-65	+150	°C
total power dissipation	P _{tot}	-	-	500	mW
device dissipation	P	per output transistor	-	100	mW
Soldering temperature	T _L	10s	DIP	245	°C
			SOP/TSSOP	260	



3.2、Recommended Operating Conditions

Parameter	Symbol	Conditions	Min.	Typ.	Max.	Unit
supply voltage	V_{DD}	-	3	-	15	V
ambient temperature	T_{amb}	in free air	-40	-	+125	°C

3.3、Electrical Characteristics

3.3.1、DC Characteristics 1

($T_{amb}=25^{\circ}\text{C}$, voltages are referenced to GND (ground=0V), unless otherwise specified.)

Parameter	Symbol	Conditions (V)			$T_{amb}=25^{\circ}\text{C}$			Unit
		V_O	V_{IN}	V_{DD}	Min.	Typ.	Max.	
supply current	I_{DD}	-	0, 5	5	-	-	1	uA
		-	0, 10	10	-	-	1	uA
		-	0, 15	15	-	-	1	uA
LOW-level output current	I_{OL}	0.4	0, 5	5	0.51	1	-	mA
		0.5	0, 10	10	1.3	2.6	-	mA
		1.5	0, 15	15	3.4	6.8	-	mA
HIGH-level output current	I_{OH}	4.6	0, 5	5	-0.51	-1	-	mA
		2.5	0, 5	5	-1.6	-3.2	-	mA
		9.5	0, 10	10	-1.3	-2.6	-	mA
		13.5	0, 15	15	-3.4	-6.8	-	mA
LOW-level output voltage	V_{OL}	-	0, 5	5	-	0	0.05	V
		-	0, 10	10	-	0	0.05	V
		-	0, 15	15	-	0	0.05	V
HIGH-level output voltage	V_{OH}	-	0, 5	5	4.95	5	-	V
		-	0, 10	10	9.95	10	-	V
		-	0, 15	15	14.95	15	-	V
LOW-level input voltage	V_{IL}	4.5	-	5	-	-	1.5	V
		9	-	10	-	-	3	V
		13.5	-	15	-	-	4	V
HIGH-level input voltage	V_{IH}	0.5, 4.5	-	5	3.5	-	-	V
		1, 9	-	10	7	-	-	V
		1.5, 13.5	-	15	11	-	-	V
input leakage current	I_I	-	0, 15	15	-	-	±1	uA



3.3.2、DC Characteristics 2

($T_{amb}=-40^{\circ}\text{C}$ to $+125^{\circ}\text{C}$, voltages are referenced to GND (ground=0V), unless otherwise specified.)

Parameter	Symbol	Conditions (V)			$T_{amb}=-40^{\circ}\text{C}$		$T_{amb}+85^{\circ}\text{C}$		$T_{amb}+125^{\circ}\text{C}$		Unit
		V_O	V_{IN}	V_{DD}	Min.	Max.	Min.	Max.	Min.	Max.	
supply current	I_{DD}	-	0, 5	5	-	1	-	7.5	-	7.5	μA
		-	0, 10	10	-	1	-	15	-	15	μA
		-	0, 15	15	-	1	-	30	-	30	μA
LOW-level output current	I_{OL}	0.4	0, 5	5	0.61	-	0.42	-	0.36	-	mA
		0.5	0, 10	10	1.5	-	1.1	-	0.9	-	mA
		1.5	0, 15	15	4	-	2.8	-	2.4	-	mA
HIGH-level output current	I_{OH}	4.6	0, 5	5	-0.61	-	-0.42	-	-0.36	-	mA
		2.5	0, 5	5	-1.8	-	-1.3	-	-1.15	-	mA
		9.5	0, 10	10	-1.5	-	-1.1	-	-0.9	-	mA
		13.5	0, 15	15	-4	-	-2.8	-	-2.4	-	mA
LOW-level output voltage	V_{OL}	-	0, 5	5	-	0.05	-	0.05	-	0.05	V
		-	0, 10	10	-	0.05	-	0.05	-	0.05	V
		-	0, 15	15	-	0.05	-	0.05	-	0.05	V
HIGH-level output voltage	V_{OH}	-	0, 5	5	4.95	-	4.95	-	4.95	-	V
		-	0, 10	10	9.95	-	9.95	-	9.95	-	V
		-	0, 15	15	14.95	-	14.95	-	14.95	-	V
LOW-level input voltage	V_{IL}	4.5	-	5	-	1.5	-	1.5	-	1.5	V
		9	-	10	-	3	-	3	-	3	V
		13.5	-	15	-	4	-	4	-	4	V
HIGH-level input voltage	V_{IH}	0.5, 4.5	-	5	3.5	-	3.5	-	3.5	-	V
		1, 9	-	10	7	-	7	-	7	-	V
		1.5, 13.5	-	15	11	-	11	-	11	-	V
input leakage current	I_I	-	0, 15	15	-	± 1	-	± 1	-	± 1	μA

3.3.3、AC Characteristics

($T_{amb}=25^{\circ}\text{C}$, GND=0V, $t_r, t_f=20\text{ns}$, $C_L=50\text{pF}$, $R_L=200\text{k}\Omega$, unless otherwise specified.)

Parameter	Symbol	Conditions	Min.	Typ.	Max.	Unit	
propagation delay time	t_{PHL}, t_{PLH}	see Figure 4	$V_{DD}=5\text{V}$	-	125	250	ns
		$V_{DD}=10\text{V}$	-	60	120	ns	
		$V_{DD}=15\text{V}$	-	45	90	ns	
transition time	t_{THL}, t_{TLH}	see Figure 4	$V_{DD}=5\text{V}$	-	100	200	ns
		$V_{DD}=10\text{V}$	-	50	100	ns	
		$V_{DD}=15\text{V}$	-	40	80	ns	
input capacitance	C_I	any input	-	5	7.5	pF	



4、Testing Circuit

4.1、AC Testing Circuit

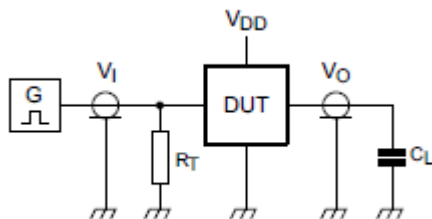

Figure 3. Test circuit for switching times

Definitions for test circuit:

DUT=Device Under Test.

C_L =Load capacitance including jig and probe capacitance.

R_T =Termination resistance should be equal to the output impedance Z_o of the pulse generator.

4.2、AC Testing Waveforms

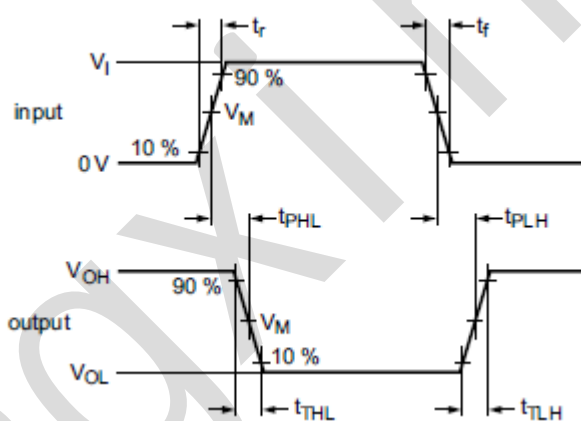

Figure 4. Propagation delay, output transition time

4.3、Measurement Points

Supply voltage	Input	Output
V_{DD}	V_M	V_M
5V to 15V	$0.5 \times V_{DD}$	$0.5 \times V_{DD}$

4.4、Test Data

Supply voltage	Input		Load
V_{DD}	V_I	t_r, t_f	C_L
5V to 15V	GND or V_{DD}	$\leq 20\text{ns}$	50pF



灵星芯微 芯片封装

5、Package Information

5.1、DIP14

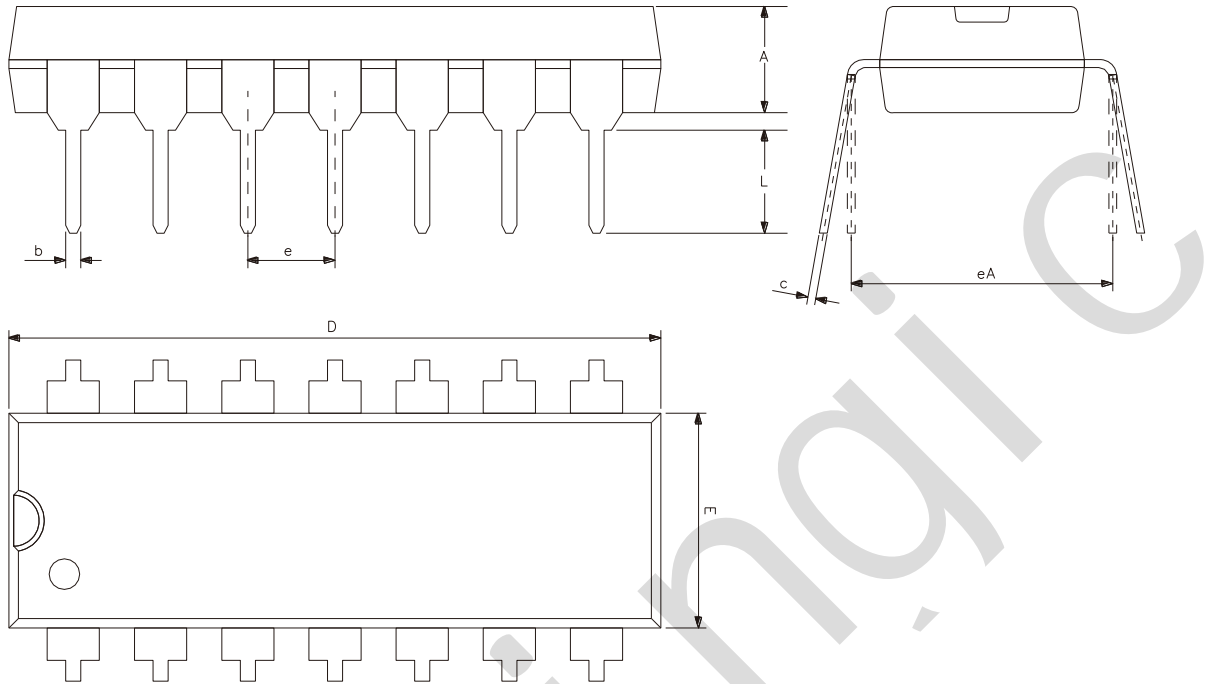

Symbol	Dimensions (mm)	
	Min.	Max.
A	3.05	3.60
b	0.33	0.56
c	0.20	0.36
D	18.80	19.40
E	6.20	6.60
e	2.54	
eA	7.62	10.90
L	2.92	-



灵星芯微 精芯经营

5.2、SOP14

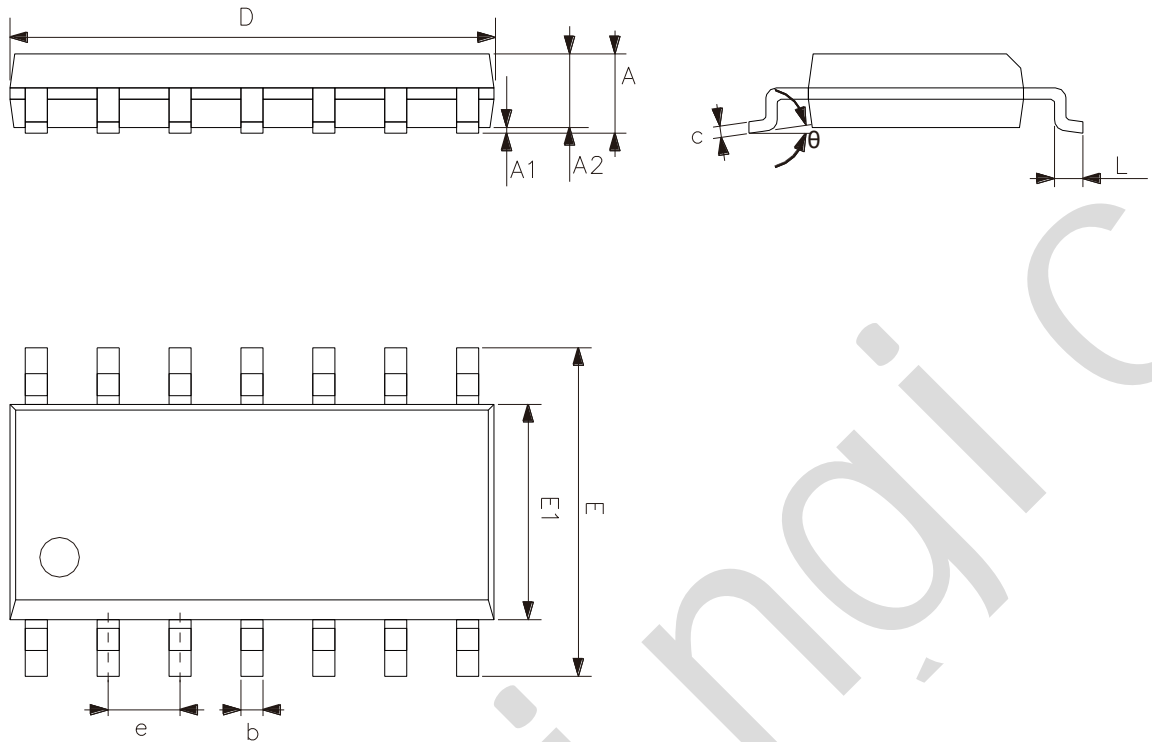

Symbol	Dimensions (mm)	
	Min.	Max.
A	1.50	1.75
A1	0.05	0.25
A2	1.30	-
b	0.33	0.50
c	0.19	0.25
D	8.43	8.76
E	5.80	6.25
E1	3.75	4.00
e	1.27	
L	0.40	0.89
θ	0°	8°



5.3、TSSOP14

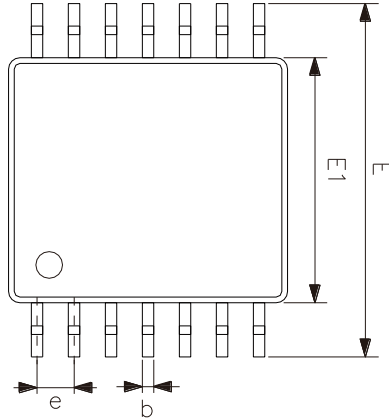
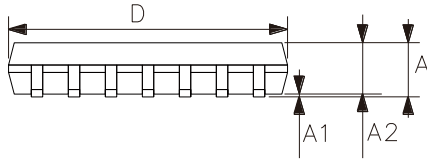

Symbol	Dimensions (mm)	
	Min.	Max.
A	-	1.20
A1	0.05	0.15
A2	0.80	1.05
b	0.19	0.30
c	0.09	0.20
D	4.90	5.10
E1	4.30	4.50
E	6.20	6.60
e	0.65	
L	0.45	0.75
L1	1.00	
θ	0°	8°



6、 Statements And Notes

6.1、 The name and content of Hazardous substances or Elements in the product

Part name	Hazardous substances or Elements									
	Lead and lead compounds	Mercury and mercury compounds	Cadmium and cadmium compounds	Hexavalent chromium compounds	Polybrominated biphenyls	Polybrominated biphenyl ethers	Dibutyl phthalate	Butylbenzyl phthalate	Di-2-ethylhexyl phthalate	Diisobutyl phthalate
Lead frame	○	○	○	○	○	○	○	○	○	○
Plastic resin	○	○	○	○	○	○	○	○	○	○
Chip	○	○	○	○	○	○	○	○	○	○
The lead	○	○	○	○	○	○	○	○	○	○
Plastic sheet installed	○	○	○	○	○	○	○	○	○	○
explanation	○: Indicates that the content of hazardous substances or elements in the detection limit of the following the SJ/T11363-2006 standard. ×: Indicates that the content of hazardous substances or elements exceeding the SJ/T11363-2006 Standard limit requirements.									

6.2、 Notes

We Recommend you to read this chapter carefully before using this product.

The information in this chapter is provided for reference only and lingxing disclaims any express or implied warranties, including but not limited to applicability, special application or non-infringement of third party rights.

This product is not suitable for critical equipment such as life-saving, life-sustaining or safety equipment. It is also not suitable for applications that may result in personal injury, death, or serious property or environmental damage due to product malfunction or failure. Lingxing will not be liable for any damages incurred by the customers at their own risk for such applications.

The customer is responsible for conducting all necessary tests lingxing's application to avoid failure in the application or the application of the customer's third party users. Lingxing does not accept any liability. The Company reserves the right to change or improve the information published in this chapter at any time. The information in this chapter are subject to change without notice. We recommend the customer to consult our sales staff before purchasing.

Please obtain related materials form lingxing's regular channels and we are not responsible for its content if it is provided by sources other than our company.

In case of any conflict between the Chinese and English version, the version is subject to the Chinese one.