

## 1. General Description

---

The EM74HC244; EM74HCT244 are 8-bit buffer/line drivers with 3-state outputs. The device can be used as two 4-bit buffers or one 8-bit buffer. The device features two output enables ( $\overline{1OE}$  and  $\overline{2OE}$ ), each controlling four of the 3-state outputs. A HIGH on  $\overline{nOE}$  causes the outputs to assume a high-impedance OFF-state. Inputs include clamp diodes that enable the use of current limiting resistors to interface inputs to voltages in excess of  $V_{CC}$ .

## 2. Features and Benefits

---

- Wide supply voltage range from 2.0 V to 6.0 V
- High noise immunity
- CMOS low power dissipation
- Latch-up performance exceeds 250 mA
- Octal bus interface
- Non-inverting 3-state outputs
- Complies with JEDEC standards:
  - JESD8C (2.7 V to 3.6 V)
  - JESD7A (2.0 V to 6.0 V)
- Input levels:
  - For EM74HC244: CMOS level
  - For EM74HCT244: TTL level
- ESD protection:
  - HBM ANSI/ESDA/JEDEC JS-001 Class 3A exceeds 6000 V
  - CDM ANSI/ESDA/JEDEC JS-002 Class C3 exceeds 2000 V
- Multiple package options

### 3. Ordering Information

Table 1. Ordering information

Type number	Topside marking	Package		
		Name	Description	Quantity
EM74HC244D	HC244□ XYYWW	SOP-20L	plastic small outline package; 20 leads; body width 7.5 mm	2000
EM74HCT244D	HCT244□ XYYWW			
EM74HC244PW	HC244□ XYYWW	TSSOP-20L	plastic thin shrink small outline package; 20 leads; body width 4.4 mm	3000
EM74HCT244PW	HCT244□ XYYWW			

**MARKING INFORMATION**

**NOTE:** HC244□ = Serial number and Internal code; XYYWW = Vendor Code and Date Code.

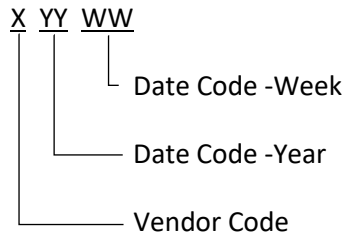
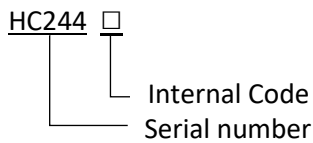

## 4. Function Diagram

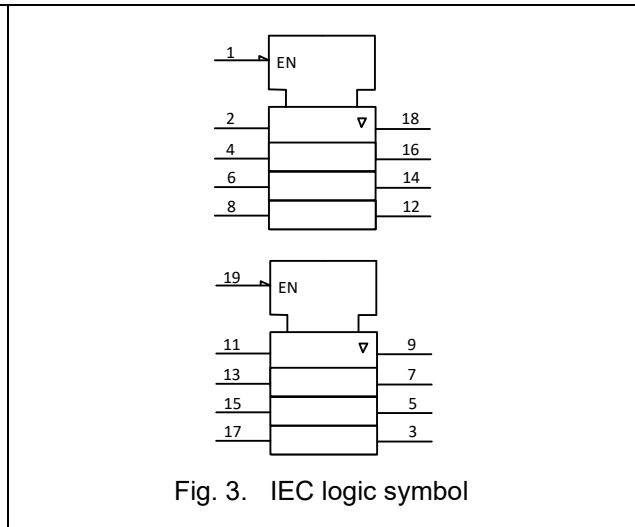
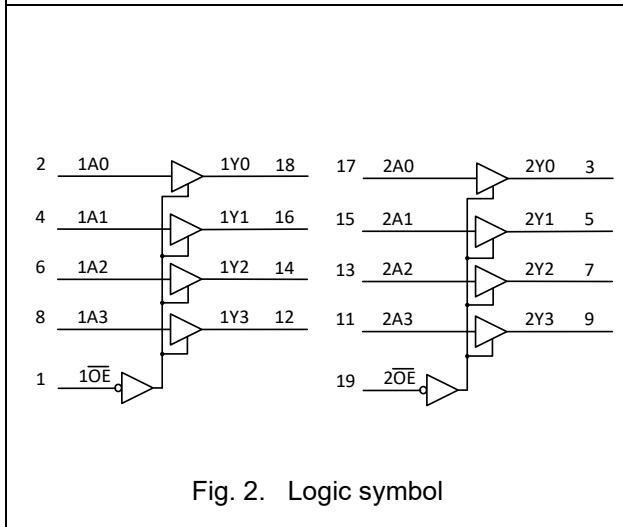
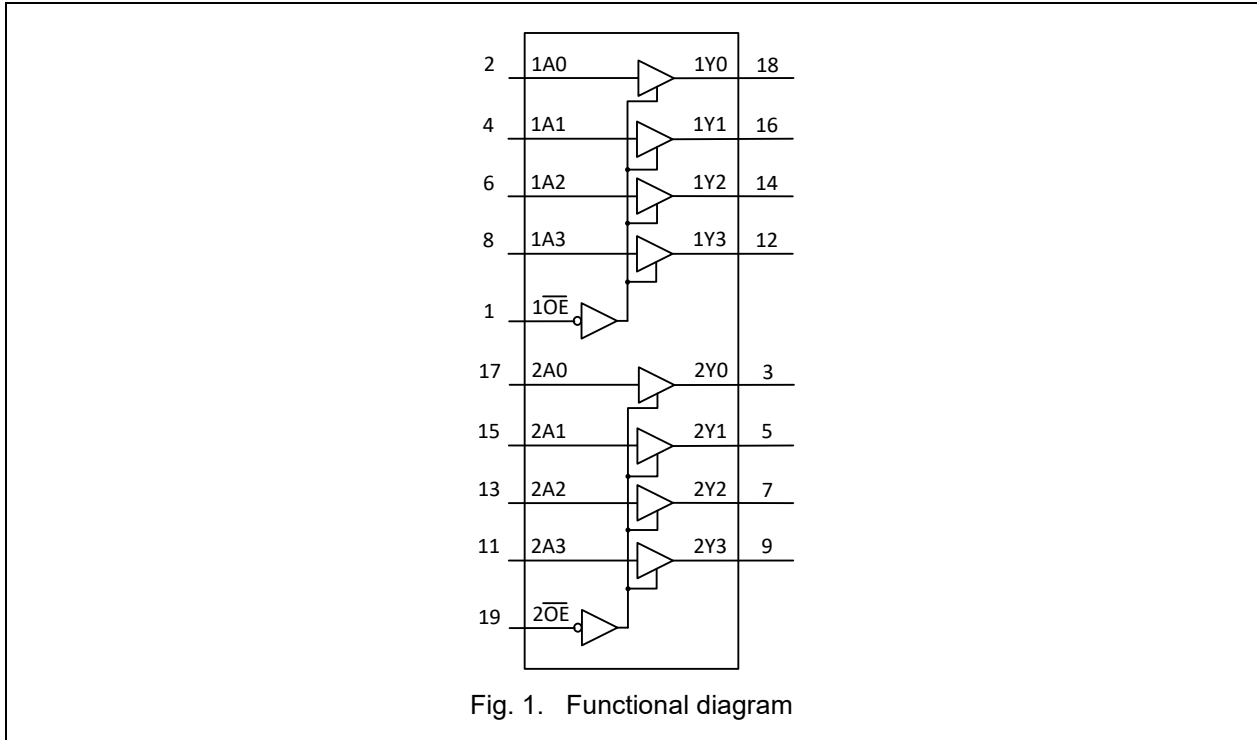

## 5. Pinning Information

### 5.1. Pinning

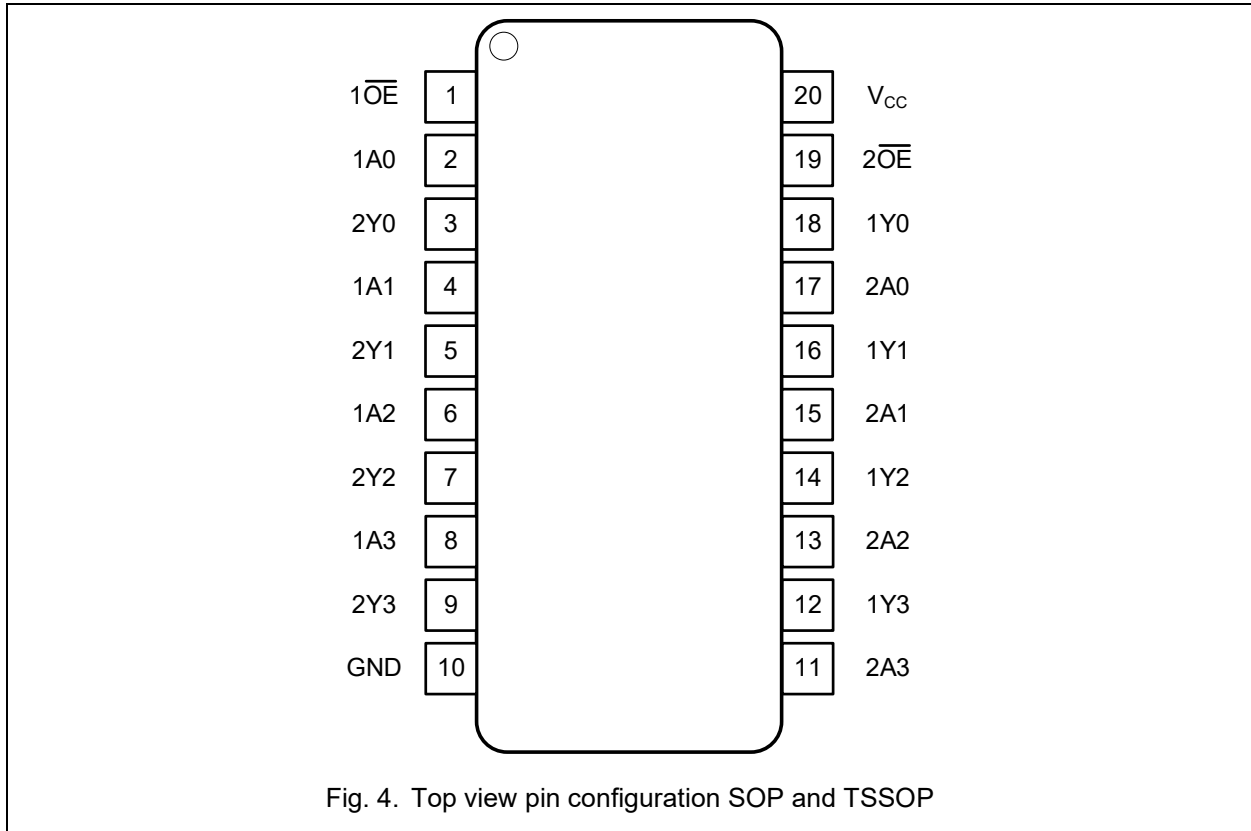

### 5.2. Pin description

Table 2. Pin description

Symbol	Pin	Description
$\overline{1OE}$ , $\overline{2OE}$	1, 19	Output enable input(active LOW)
1A0, 1A1, 1A2, 1A3	2, 4, 6, 8	Data input
2Y0, 2Y1, 2Y2, 2Y3	3, 5, 7, 9	Bus output
GND	10	Ground (0V)
2A0, 2A1, 2A2, 2A3	17, 15, 13, 11	Data input
1Y0, 1Y1, 1Y2, 1Y3	18, 16, 14, 12	Bus output
V <sub>cc</sub>	20	Supply voltage

## 6. Functional Description

**Table 3. Function table**

H = HIGH voltage level; L = LOW voltage level; X = don't care; Z = high-impedance OFF-state.

Input		Output
$\overline{nOE}$	nAn	nYn
L	L	L
L	H	H
H	X	Z

## 7. Absolute Maximum Ratings

Stresses exceeding the absolute maximum ratings may damage the device. The device may not function or be operable above the recommended operating conditions and stressing the parts to these levels is not recommended. In addition, extended exposure to stresses above the recommended operating conditions may affect device reliability. The absolute maximum ratings are stress ratings only.

**Table 4. Absolute Maximum Ratings**

In accordance with the Absolute Maximum Rating System (IEC 60134). Voltages are referenced to GND.

Symbol	Parameter	Conditions	Min	Max	Unit
$V_{CC}$	supply voltage		-0.5	7.0	V
$I_{IK}$	input clamping current	$V_I < -0.5\text{ V}$ or $V_I > V_{CC} + 0.5\text{ V}$ [1]		$\pm 20$	mA
$I_{OK}$	output clamping current	$V_O < -0.5\text{ V}$ or $V_O > V_{CC} + 0.5\text{ V}$ [1]		$\pm 20$	mA
$I_O$	output current	$V_O = -0.5\text{ V}$ to $(V_{CC} + 0.5\text{ V})$		$\pm 25$	mA
$I_{CC}$	supply current			50	mA
$I_{GND}$	ground current		-50		mA
$P_{tot}$	total power dissipation			500	mW
$T_{stg}$	storage temperature		-65	150	°C

[1] The input and output voltage ratings may be exceeded if the input and output current ratings are observed.

## 8. Recommended Operating Conditions

The Recommended Operating Conditions table defines the conditions for actual device operation. Recommended operating conditions are specified to ensure optimal performance to the datasheet specifications. EnergyMath does not recommend exceeding them or designing to Absolute Maximum Ratings.

**Table 5. Recommended Operating Conditions**

Symbol	Parameter	Conditions	EM74HC244			EM74HCT244			Unit
			Min	Typ	Max	Min	Typ	Max	
V <sub>CC</sub>	supply voltage		2.0	5.0	6.0	2.7	5.0	5.5	V
V <sub>I</sub>	input voltage		0		V <sub>CC</sub>	0		V <sub>CC</sub>	V
V <sub>O</sub>	output voltage		0		V <sub>CC</sub>	0		V <sub>CC</sub>	V
T <sub>amb</sub>	ambient temperature		-40		125	-40		125	°C
Δt/ΔV	input transition rise and fall rate	V <sub>CC</sub> = 2.0 V			625				ns/V
		V <sub>CC</sub> = 4.5 V		1.67	139		1.67	139	ns/V
		V <sub>CC</sub> = 6.0 V			83				ns/V

## 9. Static Characteristics

**Table 6. Static characteristics**

At recommended operating conditions. Voltages are referenced to GND (ground = 0 V). Typical values measured at  $T_{amb} = 25^{\circ}\text{C}$  (unless otherwise noted).

Symbol	Parameter	Conditions	-40 °C to +85 °C			-40 °C to +125 °C		Unit
			Min	Typ	Max	Min	Max	
<b>EM74HC244</b>								
$V_{IH}$	HIGH-level input voltage	$V_{CC} = 2.0\text{ V}$	1.5			1.5		V
		$V_{CC} = 4.5\text{ V}$	3.15			3.15		V
		$V_{CC} = 6.0\text{ V}$	4.2			4.2		V
$V_{IL}$	LOW-level input voltage	$V_{CC} = 2.0\text{ V}$			0.5		0.5	V
		$V_{CC} = 4.5\text{ V}$			1.35		1.35	V
		$V_{CC} = 6.0\text{ V}$			1.8		1.8	V
$V_{OH}$	HIGH-level output voltage	$V_I = V_{IH}$ or $V_{IL}$						
		$I_O = -20\ \mu\text{A}$ ; $V_{CC} = 2.0\text{ V}$	1.9			1.9		V
		$I_O = -20\ \mu\text{A}$ ; $V_{CC} = 4.5\text{ V}$	4.4			4.4		V
		$I_O = -20\ \mu\text{A}$ ; $V_{CC} = 6.0\text{ V}$	5.9			5.9		V
		$I_O = -6.0\text{ mA}$ ; $V_{CC} = 4.5\text{ V}$	3.84			3.7		V
		$I_O = -7.8\text{ mA}$ ; $V_{CC} = 6.0\text{ V}$	5.34			5.2		V
$V_{OL}$	LOW-level output voltage	$V_I = V_{IH}$ or $V_{IL}$						
		$I_O = 20\ \mu\text{A}$ ; $V_{CC} = 2.0\text{ V}$			0.1		0.1	V
		$I_O = 20\ \mu\text{A}$ ; $V_{CC} = 4.5\text{ V}$			0.1		0.1	V
		$I_O = 20\ \mu\text{A}$ ; $V_{CC} = 6.0\text{ V}$			0.1		0.1	V
		$I_O = 6.0\text{ mA}$ ; $V_{CC} = 4.5\text{ V}$			0.33		0.4	V
		$I_O = 7.8\text{ mA}$ ; $V_{CC} = 6.0\text{ V}$			0.33		0.4	V
$I_I$	input leakage current	$V_I = V_{CC}$ or GND ; $V_{CC} = 6.0\text{ V}$			$\pm 1$		$\pm 1$	$\mu\text{A}$
$I_{OZ}$	OFF-state output current	$V_I = V_{IH}$ or $V_{IL}$ ; $V_{CC} = 6.0\text{ V}$ ; $V_O = V_{CC}$ or GND			$\pm 5$		$\pm 10$	$\mu\text{A}$
$I_{CC}$	supply current	$V_I = V_{CC}$ or GND ; $I_O = 0\text{ A}$ ; $V_{CC} = 6.0\text{ V}$			20		40	$\mu\text{A}$
$C_i$	input capacitance	Pin $\overline{\text{OE}}$		4.0				pF
		Pin nAn		7.7				pF

**EM74HC244; EM74HCT244**

Octal buffer/line driver; 3-state

Symbol	Parameter	Conditions	-40 °C to +85 °C			-40 °C to +125 °C		Unit
			Min	Typ	Max	Min	Max	
<b>EM74HCT244</b>								
V <sub>IH</sub>	HIGH-level input voltage	V <sub>CC</sub> = 3 V	2.0			2.0		V
		V <sub>CC</sub> = 4.5 V	2.0			2.0		V
		V <sub>CC</sub> = 5.5 V	2.1			2.1		V
V <sub>IL</sub>	LOW-level input voltage	V <sub>CC</sub> = 3 V			0.7		0.7	V
		V <sub>CC</sub> = 4.5 V			0.8		0.8	V
		V <sub>CC</sub> = 5.5 V			0.8		0.8	V
V <sub>OH</sub>	HIGH-level output voltage	V <sub>I</sub> = V <sub>IH</sub> or V <sub>IL</sub> ;						
		I <sub>O</sub> = -20 μA; V <sub>CC</sub> = 3 V	2.9			2.9		V
		I <sub>O</sub> = -20 μA; V <sub>CC</sub> = 4.5 V	4.4			4.4		V
		I <sub>O</sub> = -6.0 mA; V <sub>CC</sub> = 4.5 V	3.84			3.7		V
V <sub>OL</sub>	LOW-level output voltage	V <sub>I</sub> = V <sub>IH</sub> or V <sub>IL</sub> ;						
		I <sub>O</sub> = 20 μA; V <sub>CC</sub> = 3 V			0.1		0.1	V
		I <sub>O</sub> = 20 μA; V <sub>CC</sub> = 4.5 V			0.1		0.1	V
		I <sub>O</sub> = 6.0 mA; V <sub>CC</sub> = 4.5 V			0.33		0.4	V
I <sub>I</sub>	input leakage current	V <sub>I</sub> = V <sub>CC</sub> or GND ; V <sub>CC</sub> = 5.5 V			±1		±1	μA
I <sub>OZ</sub>	OFF-state output current	V <sub>I</sub> = V <sub>IH</sub> or V <sub>IL</sub> ; V <sub>CC</sub> = 5.5 V ; V <sub>O</sub> = V <sub>CC</sub> or GND			±5		±10	μA
I <sub>CC</sub>	supply current	V <sub>I</sub> = V <sub>CC</sub> or GND; I <sub>O</sub> = 0 A; V <sub>CC</sub> = 5.5 V			20		40	μA
ΔI <sub>CC</sub>	additional supply current	per pin ; V <sub>I</sub> = V <sub>CC</sub> - 2.1 V; I <sub>O</sub> = 0 A; other inputs at V <sub>CC</sub> or GND; V <sub>CC</sub> = 4.5 V to 5.5 V			400		490	μA
C <sub>I</sub>	input capacitance	Pin $\overline{OE}$		4.0				pF
		Pin nAn		7.7				pF

## 10. Dynamic Characteristics

**Table 7. Dynamic characteristics**

Voltages are referenced to GND (ground = 0 V); for test circuit see Fig. 7. Typical values measured at  $T_{amb} = 25^{\circ}\text{C}$  (unless otherwise noted).

Symbol	Parameter	Conditions	-40 °C to +85 °C			-40 °C to +125 °C		Unit
			Min	Typ	Max	Min	Max	
<b>EM74HC244</b>								
$t_{pd}$	propagation delay	nAn to nYn; see Fig. 5 [1]						
		$V_{CC} = 2.0\text{ V}$			35		40	ns
		$V_{CC} = 4.5\text{ V}$			20		25	ns
		$V_{CC} = 6.0\text{ V}$			15		20	ns
$t_{en}$	enable time	$\overline{nOE}$ to nYn; see Fig. 6 [2]						
		$V_{CC} = 2.0\text{ V}$			35		40	ns
		$V_{CC} = 4.5\text{ V}$			20		25	ns
		$V_{CC} = 6.0\text{ V}$			15		20	ns
$t_{dis}$	disable time	$\overline{nOE}$ to nYn; see Fig. 6 [3]						
		$V_{CC} = 2.0\text{ V}$			35		40	ns
		$V_{CC} = 4.5\text{ V}$			20		25	ns
		$V_{CC} = 6.0\text{ V}$			15		20	ns
$t_t$	transition time	see Fig. 5 [4]						
		$V_{CC} = 2.0\text{ V}$			9		11	ns
		$V_{CC} = 4.5\text{ V}$			6		8	ns
		$V_{CC} = 6.0\text{ V}$			4		5	ns
$C_{PD}$	power dissipation capacitance	Per buffer ; $V_I = \text{GND to } V_{CC}$ [5]		18				pF

## EM74HC244; EM74HCT244

Octal buffer/line driver; 3-state

Symbol	Parameter	Conditions	-40 °C to +85 °C			-40 °C to +125 °C		Unit
			Min	Typ	Max	Min	Max	
<b>EM74HCT244</b>								
$t_{pd}$	propagation delay	nA to nY; $V_{CC} = 4.5\text{ V}$ ; see Fig. 5 [1]			20		25	ns
$t_{en}$	enable time	$\overline{nOE}$ to nYn; $V_{CC} = 4.5\text{ V}$ ; see Fig. 6 [2]			20		25	ns
$t_{dis}$	disable time	$\overline{nOE}$ to nYn; $V_{CC} = 4.5\text{ V}$ ; see Fig. 6 [3]			20		25	ns
$t_t$	transition time	$V_{CC} = 4.5\text{ V}$ ; see Fig. 5 [4]			6		8	ns
$C_{PD}$	power dissipation capacitance	per buffer ; $V_I = \text{GND to } (V_{CC} - 1.5\text{ V})$ [5]		18				pF

[1]  $t_{pd}$  is the same as  $t_{PHL}$  and  $t_{PLH}$ .

[2]  $t_{en}$  is the same as  $t_{PZH}$  and  $t_{PZL}$ .

[3]  $t_{dis}$  is the same as  $t_{PLZ}$  and  $t_{PHZ}$ .

[4]  $t_t$  is the same as  $t_{THL}$  and  $t_{TLH}$ .

[5]  $C_{PD}$  is used to determine the dynamic power dissipation ( $P_D$  in  $\mu\text{W}$ ).

$$P_D = C_{PD} \times V_{CC}^2 \times f_i \times N + \sum(C_L \times V_{CC}^2 \times f_o) \text{ where:}$$

$f_i$  = input frequency in MHz;

$f_o$  = output frequency in MHz;

$C_L$  = output load capacitance in pF;

$V_{CC}$  = supply voltage in V;

$N$  = number of inputs switching;

$\sum(C_L \times V_{CC}^2 \times f_o)$  = sum of outputs.

### 10.1. Waveforms and test circuit

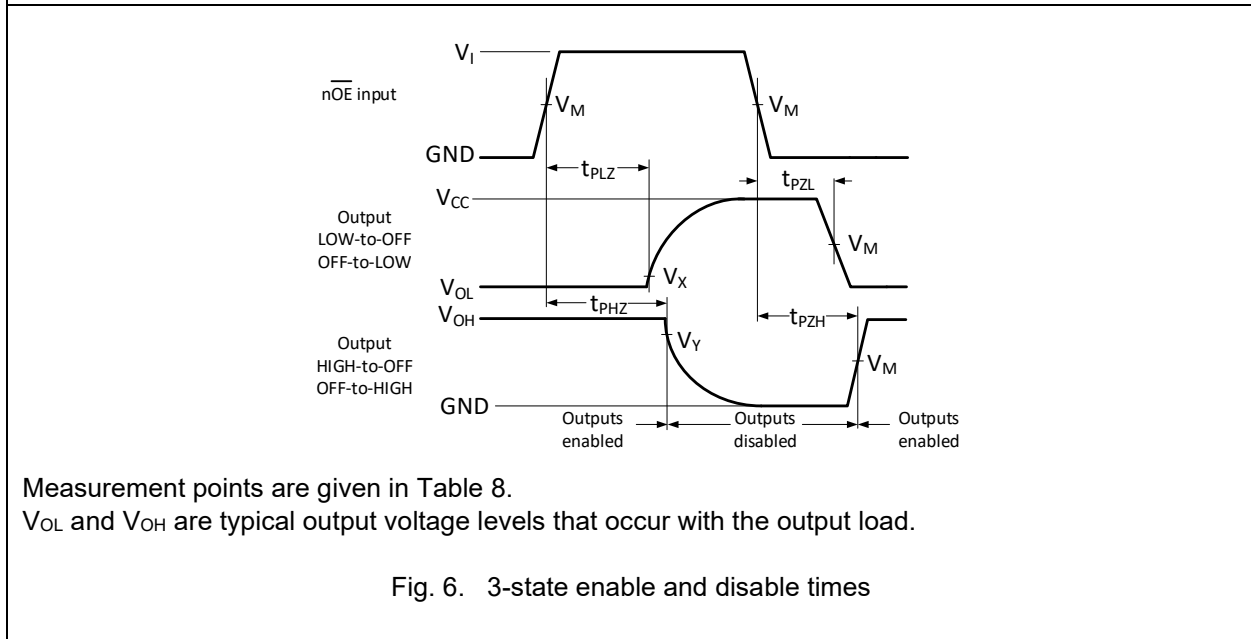
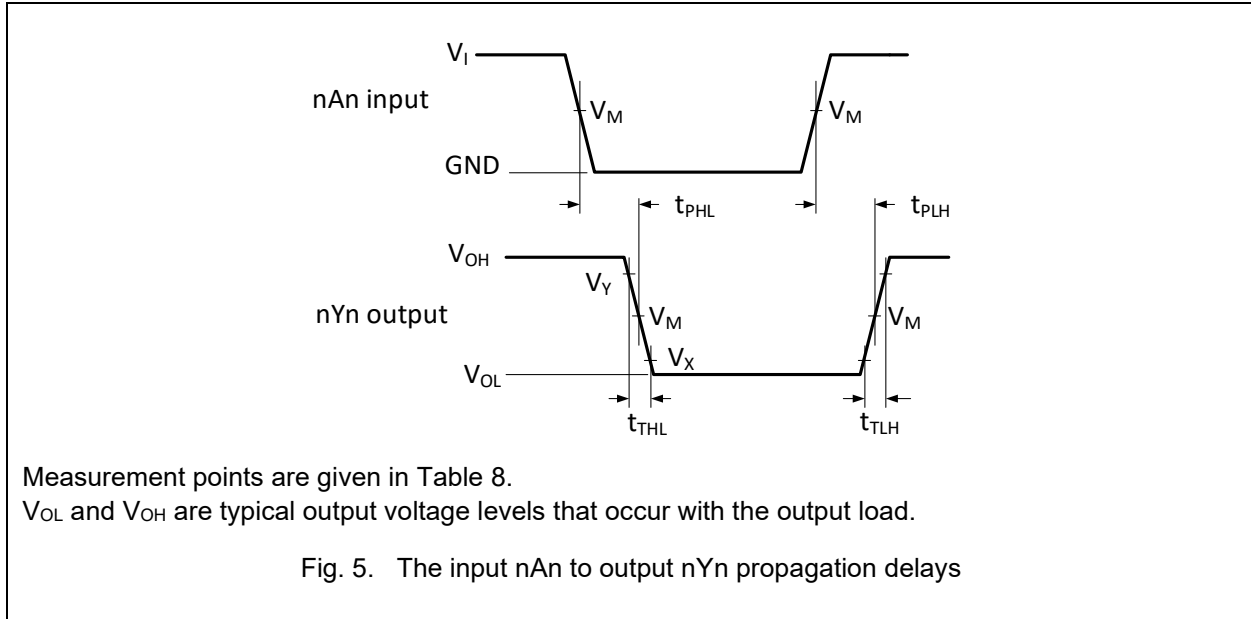
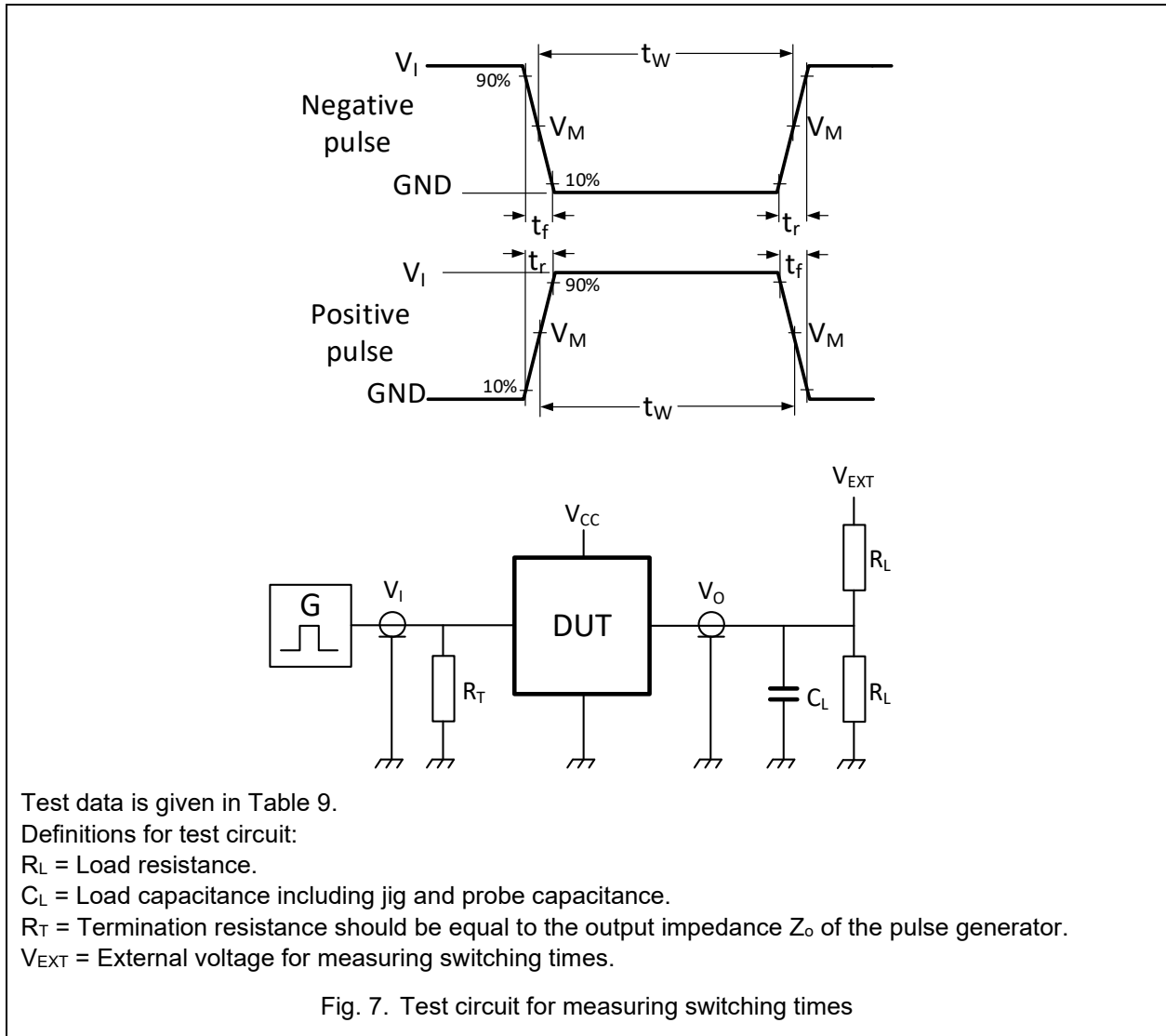

**Table 8. Measurement points**

Type	Input	Output		
	$V_M$	$V_M$	$V_X$	$V_Y$
EM74HC244	$0.5V_{CC}$	$0.5V_{CC}$	$0.1V_{CC}$	$0.9V_{CC}$
EM74HCT244	1.3 V	1.3 V	$0.1V_{CC}$	$0.9V_{CC}$

**EM74HC244; EM74HCT244**

**Octal buffer/line driver; 3-state**

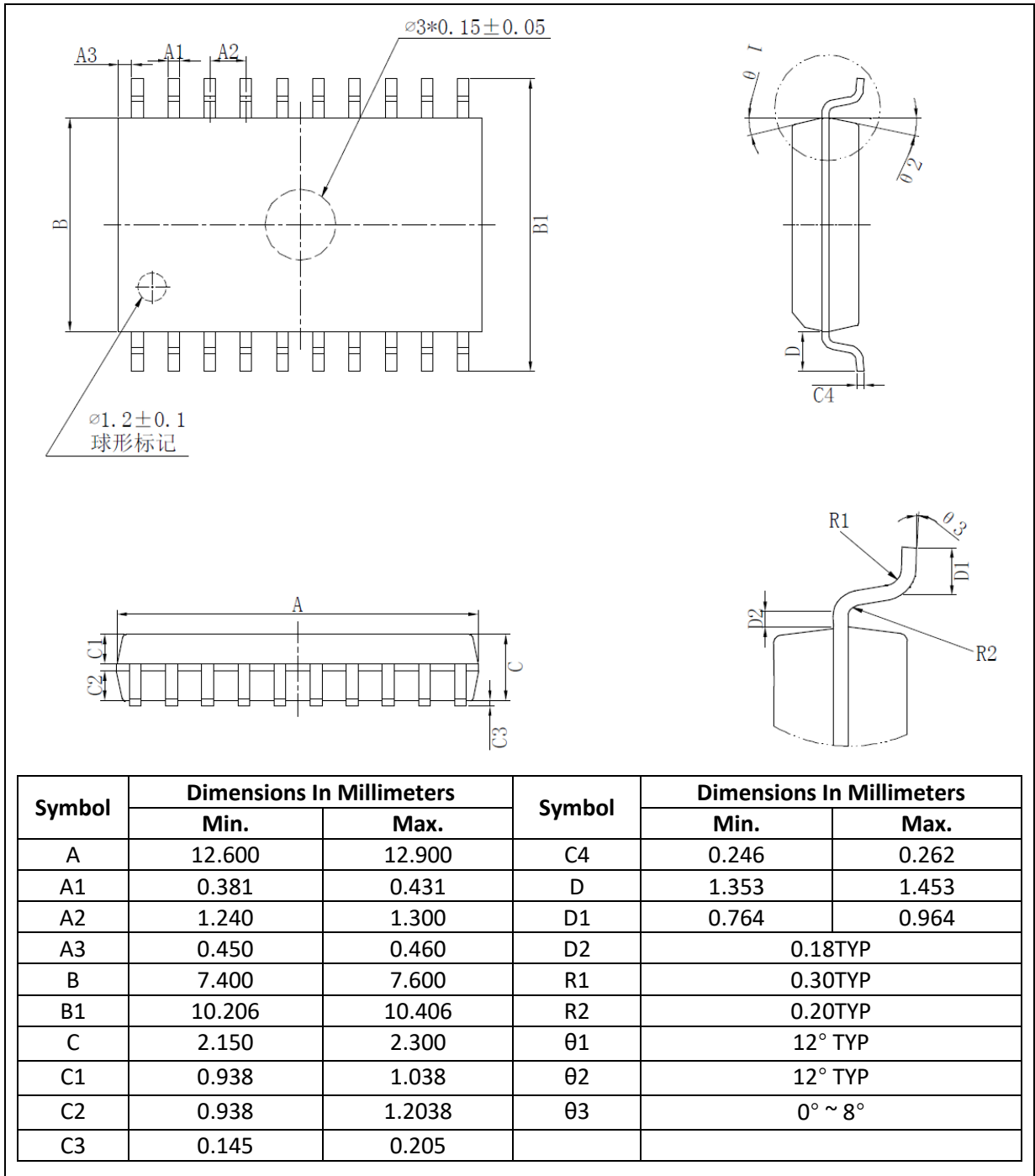

**Table 9. Test data**

Type	Input		Load		$V_{EXT}$		
	$V_I$	$t_r = t_f$	$C_L$	$R_L$	$t_{PLH}, t_{PHL}$	$t_{PZH}, t_{PHZ}$	$t_{PZL}, t_{PLZ}$
EM74HC244	$V_{CC}$	$\leq 2.5$ ns	50 pF	500 $\Omega$	open	GND	$2V_{CC}$
EM74HCT244	3 V	$\leq 2.5$ ns	50 pF	500 $\Omega$	open	GND	$2V_{CC}$

# 11. Package Outline

SOP-20L



**EM74HC244; EM74HCT244**

Octal buffer/line driver; 3-state

**TSSOP-20L**

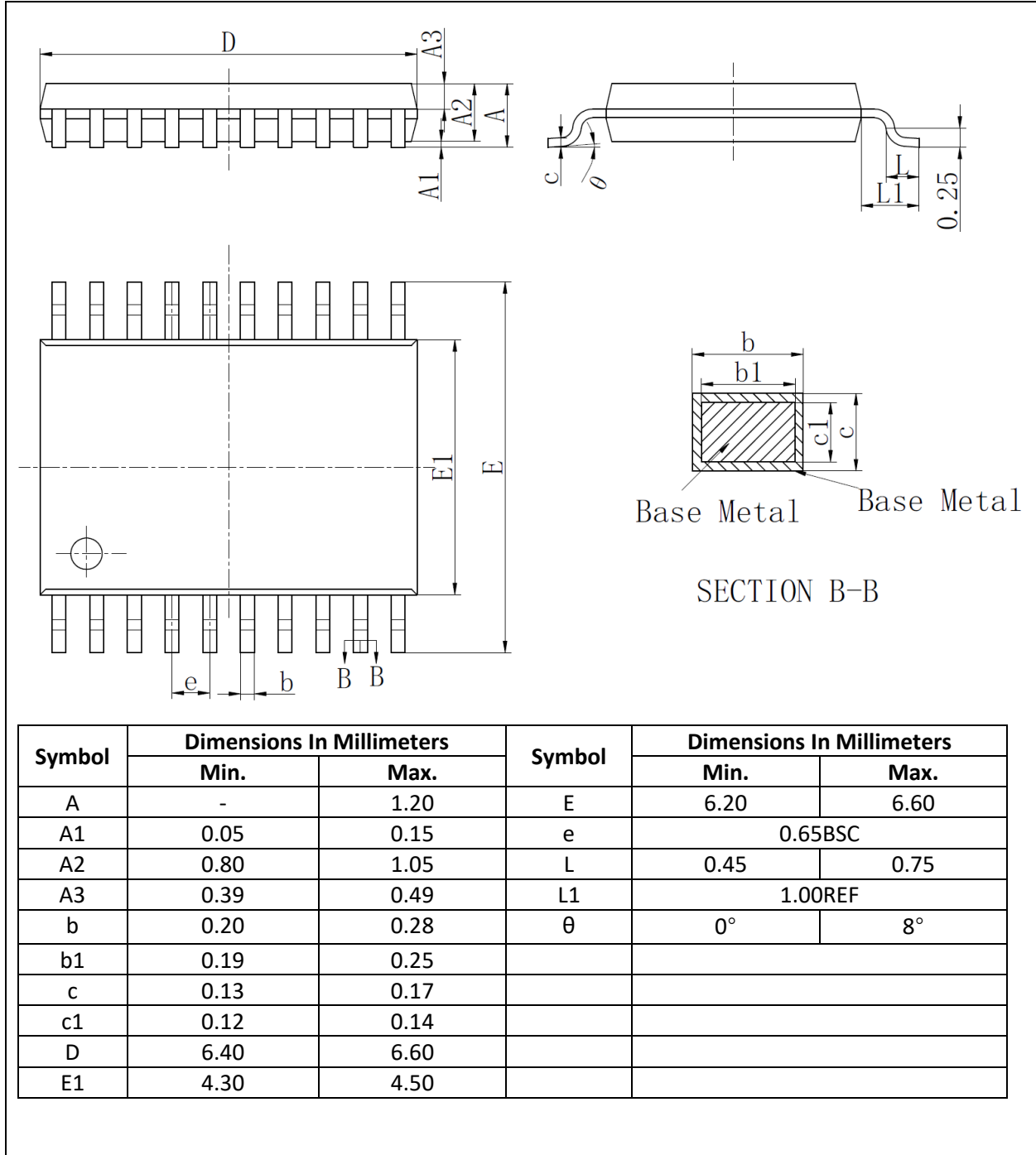

## 12. Tape and Reel Information

### 12.1. Carrier tape dimensions

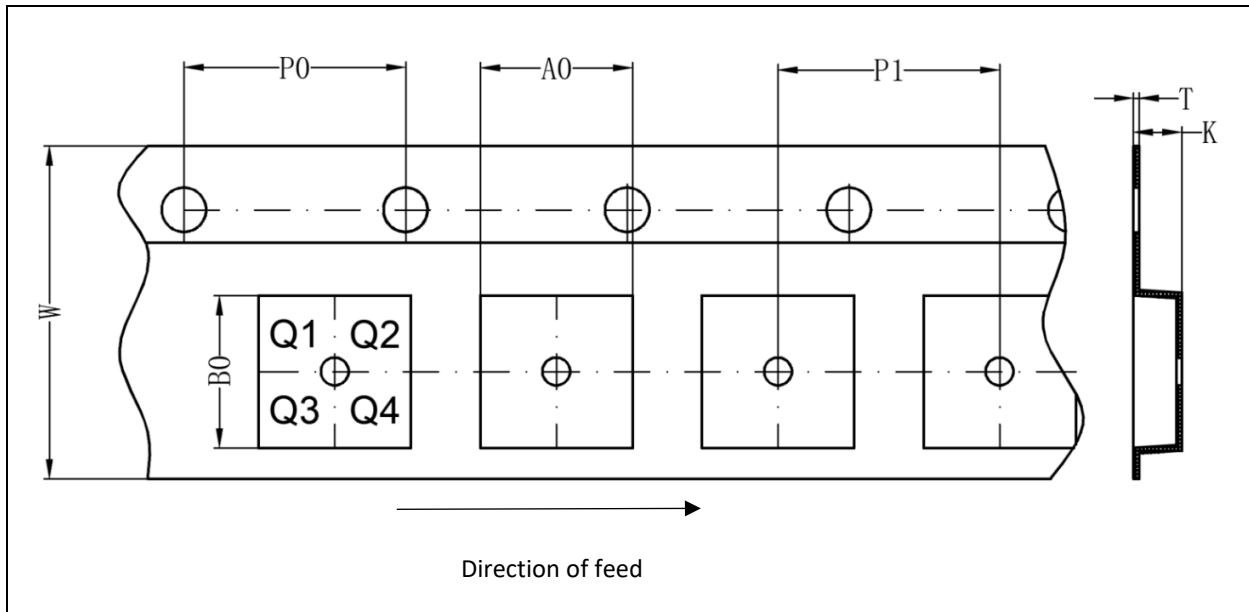
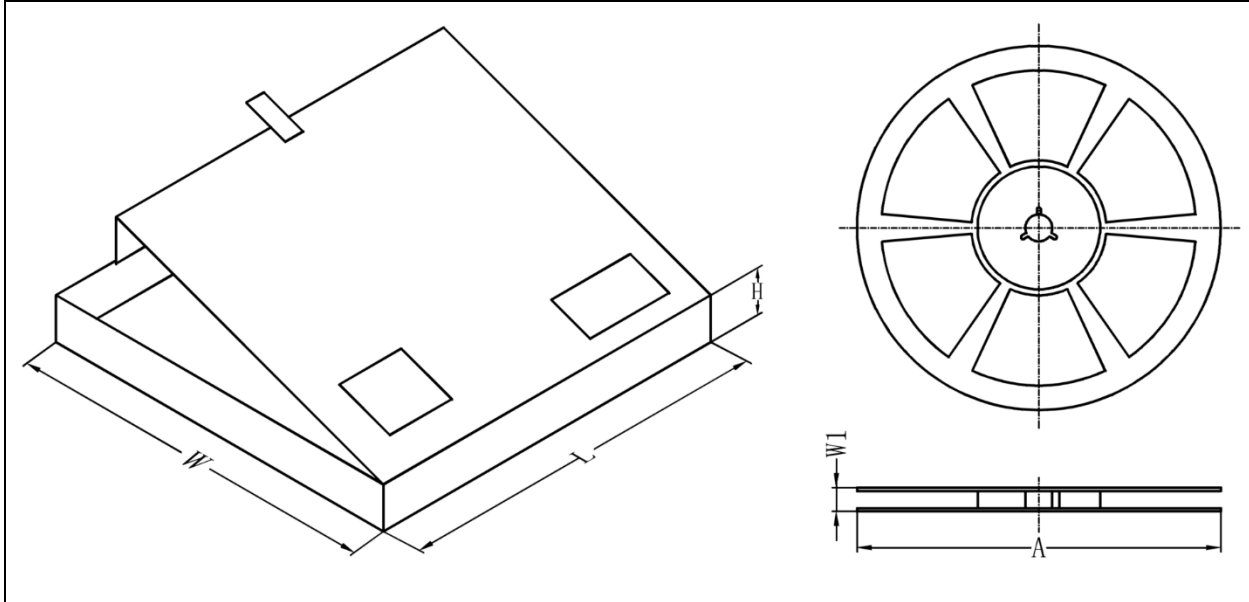

Table 10. Carrier tape dimensions

Package version	A0(mm)	B0(mm)	K0(mm)	T(mm)	P1(mm)	W(mm)	P0(mm)	PIN 1
SOP-20L	10.65	13.2	3.2	0.3	12	24	4	Q1
TSSOP-20L	6.85	6.85	1.7	0.22	8	12	4	Q1

## 12.2. Reel and box dimensions



**Table 11. Dimensions and quantities**

Package version	Type NO. ending	Reel Dimension A (mm)	Reel Width W1 (mm)	SPQ (pcs) [1]	Reels per box	Outer box dimensions L×W×H(mm) [2]
SOP-20L	D	330	30.4	2000	1	358x340x50
TSSOP-20L	PW	330	18.4	3000	1	358x340x50

[1] Packing quantity dependent on specific product type. Please contact your local Energymath representative for ordering.

[2] Dimensions for reference only.

## 13. Abbreviations

**Table 12. Abbreviations**

Acronym	Description
CMOS	Complementary Metal-Oxide Semiconductor
DUT	Device Under Test
ESD	ElectroStatic Discharge
HBM	Human Body Model
CDM	Charged Device Model
TTL	Transistor-Transistor Logic

## 14. Revision History

**Table 13. Revision history**

Document ID	Release Date	Data sheet status	Change notice	Supersedes
EM74HC_HCT244 Rev. 1.3	Dec 15, 2025	Product datasheet		EM74HC_HCT244 Rev. 1.2
Modifications:	<ul style="list-style-type: none"> <li>Table 1: topside marking information updated</li> <li>Section 12: tape and reel information added.</li> </ul>			
EM74HC_HCT244 Rev. 1.2	May 22, 2025	Product datasheet		EM74HC_HCT244 Rev. 1.1
Modifications:	<ul style="list-style-type: none"> <li>Update <math>V_{IL}</math> of EM74HCT244.</li> </ul>			
EM74HC_HCT244 Rev. 1.1	Apr 22, 2025	Product datasheet		EM74HC_HCT244 Rev. 1.0
Modifications:	<ul style="list-style-type: none"> <li>Update supply voltage range of EM74HCT244.</li> </ul>			
EM74HC_HCT244 Rev. 1.0	Nov 01, 2024	Product datasheet		