

Quad 2-Input Or Gate

Features

- Wide operating voltage range $V_{DD}=3V$ to 18V
- Fully static operation
- 5V-10V-15V parametric ratings
- Standardized symmetrical output characteristics
- Inputs and outputs are protected against electrostatic effects
- Specified from $-40^{\circ}C$ to $+85^{\circ}C$

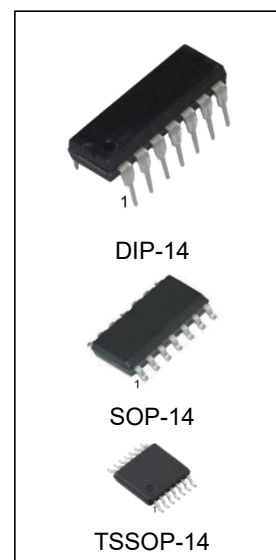

Ordering Information

DEVICE	Package Type	MARKING	Packing	Packing Qty
CD4071BPG	DIP-14	CD4071B	TUBE	1000pcs/box
CD4071BPG-HX	DIP-14	CD4071B	TUBE	1000pcs/box
CD4071BDRG	SOP-14	CD4071B	REEL	2500pcs/reel
CD4071BDRG-HX	SOP-14	CD4071B	REEL	2500pcs/reel
CD4071BDRG4	SOP-14	CD4071B	REEL	4000pcs/reel
CD4071BDRG4-HX	SOP-14	CD4071B	REEL	4000pcs/reel
CD4071BPWRG	TSSOP-14	CD4071B	REEL	2500pcs/reel
CD4071BPWRG-HX	TSSOP-14	CD4071B	REEL	2500pcs/reel

Note: The device name suffix is HX, which is only for online channel use and has no difference from those without the HX suffix.

Description

The CD4071B is a quad 2-input OR gate, These quad gates are monolithic complementary MOS(CMOS) integrated circuits constructed with N- and P-channel enhancement mode transistors.

They have equal source and sink current capabilities. The devices also have buffered outputs which improve transfer characteristics by providing very high gain. All inputs are buffered.

Logic Diagram

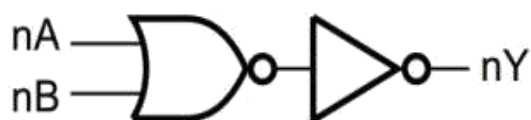

Logic Diagram (one gate)

Truth Table

Input		Outputs
nA	nB	Y
0	0	0
0	1	1
1	0	1
1	1	1

Connection Diagrams

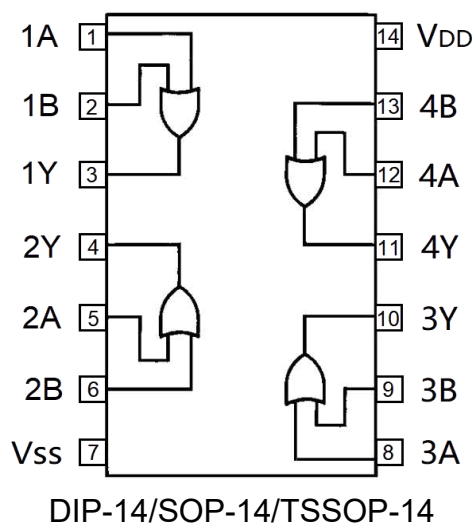

Pin Description

PIN No.	NAME	I/O	FUNCTION
1	1A	I	Data Input
2	1B	I	Data Input
3	1Y	O	Data Output
4	2Y	O	Data Output
5	2A	I	Data Input
6	2B	I	Data Input
7	V _{SS}	-	Ground
8	3A	I	Data Input
9	3B	I	Data Input
10	3Y	O	Data Output
11	4Y	O	Data Output
12	4A	I	Data Input
13	4B	I	Data Input
14	V _{DD}	-	Positive Supply Voltage

Absolute Maximum Ratings

Symbol	Parameter	MIN	MAX	Unit
V _{DD}	Supply Voltage	-0.5	20	V
V _I	DC Input Voltage	0.5	V _{CC} +0.5	V
P _D	Power Dissipation		500	mW
T _J	Junction Temperature		125	°C
T _{OP}	Operating Temperature	-40	85	°C
T _L	Lead Temperature (10 Seconds)		260	°C

Absolute maximum ratings are those values beyond which the device could be permanently damaged, These are stress ratings only, which do not imply functional operation of the device at these or any other conditions beyond those indicated under Recommended Operating Conditions.

Electrical Characteristics

(T_a=25°C, voltages are referenced to VSS (ground=0V), unless otherwise specified)

Symbol	Parameter	Test Condition			MIN	TYP	MAX	Unit
		V _O	V _{IN}	V _{DD}				
I _{DD}	Supply Current		0,5	5	--		1	uA
			0,10	10	--		1	uA
			0,18	18	--		2	uA
I _{OL}	Low Level Output Current	0.4	0,5	5	1	2	--	mA
		0.5	0,10	10	2	5	--	mA
		1.5	0,15	15	10	20	--	mA
I _{OH}	High Level Output Current	4.6	0,5	5	-0.5	-1	--	mA
		2.5	0,5	5	-2	-4	--	mA
		9.5	0,10	10	-1	-2.2	--	mA
		13.5	0,15	15	-4	-8	--	mA
V _{OL}	Low Level Output Voltage		0,5	5	--	0.0	0.05	V
			0,10	10	--	0.0	0.05	V
			0,15	15	--	0.0	0.05	V
V _{OH}	High Level Output Voltage		0,5	5	4.95	5	--	V
			0,10	10	9.95	10	--	V
			0,15	15	14.95	15	--	V
V _{IL}	Low Level Output Voltage	0.5,4.5		5	--		1.5	V
		1.9		10	--		3	V
		1.5,13.5		15	--		4	V
V _{IH}	High Level Output Voltage	0.5		5	3.5		--	V
		1		10	7		--	V
		1.5		15	11		--	V
I _I	Input Leakage Current		0,18	18	--		±1	uA

Physical Dimensions

DIP-14

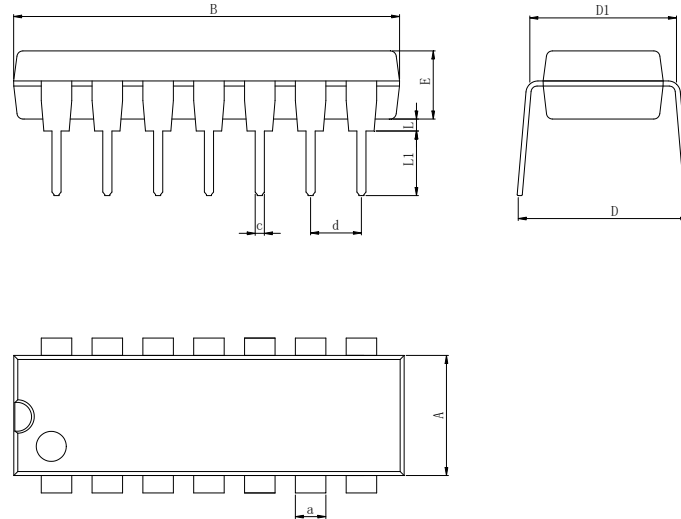

Dimensions In Millimeters(DIP-14)										
Symbol:	A	B	D	D1	E	L	L1	a	c	d
Min:	6.10	18.94	8.10	7.42	3.10	0.50	3.00	1.50	0.40	2.54 BSC
Max:	6.68	19.56	10.9	7.82	3.55	0.70	3.60	1.55	0.50	

SOP-14

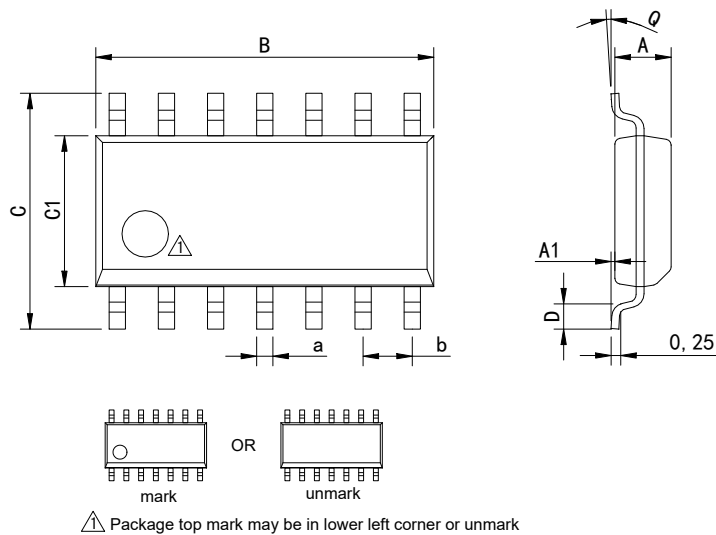

Dimensions In Millimeters(SOP-14)										
Symbol:	A	A1	B	C	C1	D	Q	a	b	
Min:	1.35	0.05	8.55	5.80	3.80	0.40	0°	0.35	1.27 BSC	
Max:	1.55	0.20	8.95	6.20	4.00	0.80	8°	0.45		

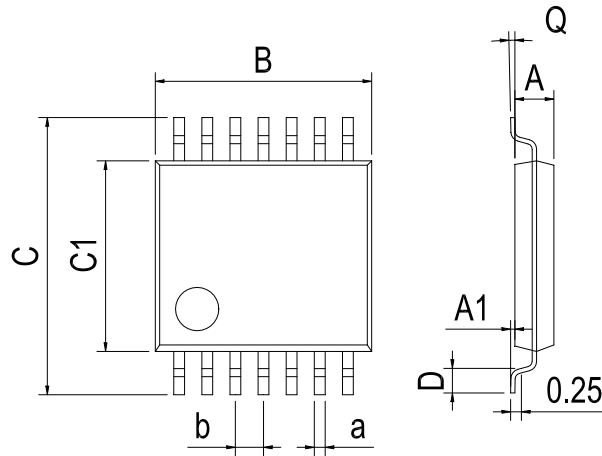
TSSOP-14

Dimensions In Millimeters(TSSOP-14)									
Symbol:	A	A1	B	C	C1	D	Q	a	b
Min:	0.85	0.05	4.90	6.20	4.30	0.40	0°	0.20	0.65 BSC
Max:	0.95	0.20	5.10	6.60	4.50	0.80	8°	0.25	

Revision History

REVISION NUMBER	DATE	REVISION	PAGE
V1.0	2019-11	New	1-5
V1.1	2025-8	Document Reformatting	1-8
V1.2	2025-12	Update Ordering Information	1

IMPORTANT STATEMENT:

Hanschip Semiconductor reserves the right to change products and services offered without prior notice. Customers should obtain the latest relevant information before placing orders and verify that such information is current and complete. Hanschip Semiconductor assumes no responsibility or liability for altered documents.

Customers are responsible for complying with safety standards and implementing safety measures when using Hanschip Semiconductor products in system design and end-product manufacturing. You assume full responsibility for: selecting the appropriate Hanschip Semiconductor products for your application; designing, validating, and testing your application; and ensuring that your application complies with applicable standards and all other safety, security, or other requirements. This is to prevent potential risks that may lead to personal injury or property damage.

Hanschip Semiconductor products are not approved for use in life support, military, aerospace, or other high-risk applications. Hanschip products are neither intended nor warranted for use in such systems or equipment. Any failure or malfunction may lead to personal injury or severe property damage. Such applications are deemed "Unsafe Use." Unsafe Use includes, but is not limited to: surgical and medical equipment, nuclear energy control equipment, aircraft or spacecraft instruments, control or operation of vehicle power, braking, or safety systems, traffic signal instruments, all types of safety devices, and any other applications intended to support or sustain life. Hanschip Semiconductor shall not be liable for consequences resulting from Unsafe Use in these fields. Users must independently evaluate and assume all risks. Any issues, liabilities, or losses arising from the use of products beyond their approved applications shall be solely borne by the user. Users may not claim any compensation from Hanschip Semiconductor based on these terms. If any third party claims against Hanschip Semiconductor due to such Unsafe Use, the user shall compensate Hanschip Semiconductor for all resulting damages and liabilities.

Hanschip Semiconductor provides technical and reliability data (including datasheets), design resources (including reference designs), application or other design advice, web tools, safety information, and other resources for its semiconductor products. However, no guarantee is made that these resources are free from defects, and no express or implied warranties are provided. The use of testing and other quality control techniques is limited to Hanschip Semiconductor's quality assurance scope. Not all parameters of each device are tested.

Hanschip Semiconductor's documentation authorizes you to use these resources only for developing applications related to the products described herein. You are not granted rights to any other intellectual property of Hanschip Semiconductor or any third party. Any other reproduction or display of these resources is strictly prohibited. You shall fully indemnify Hanschip Semiconductor and its agents against any claims, damages, costs, losses, and liabilities arising from your use of these resources. Hanschip Semiconductor shall not be held responsible.