

**SCHOTTKY BARRIER DIODE**

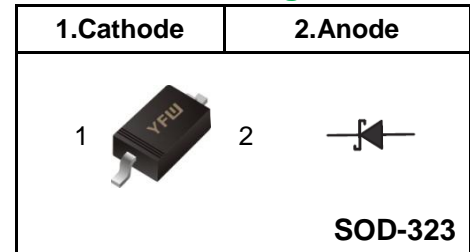
**FEATURES**

- ◆ Low Forward Voltage Drop
- ◆ Guard Ring Construction for Transient Protection
- ◆ Negligible Reverse Recovery Time
- ◆ Low Capacitance
- ◆ Lead free in comply with EU RoHS 2011/65/EU directives

**MECHANICAL DATA**

- ◆ Case: SOD-323
- ◆ Terminals: Solderable per MIL-STD-750, Method 2026
- ◆ Approx. Weight: 5.48mg / 0.00019oz

**Pinning**



**Marking Code**

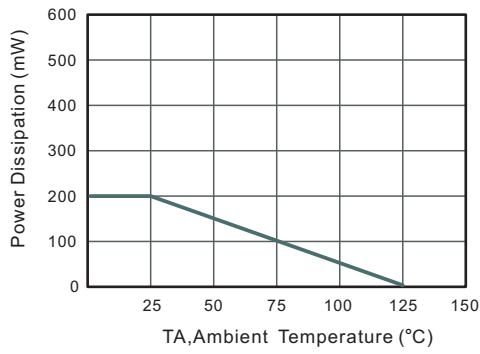
<b>1N5819WS</b>	<b>S4</b>
<b>1N5818WS</b>	<b>S5</b>
<b>1N5817WS</b>	<b>S6</b>

**Maximum Ratings and Electrical characteristics**

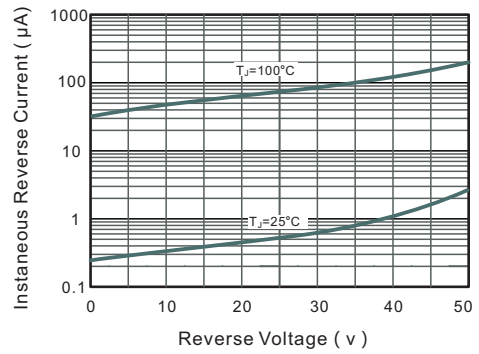
Ratings at 25 °C ambient temperature unless otherwise specified.

Parameter		Symbols	1N5819WS	1N5818WS	1N5817WS	Units
Peak Repetitive Reverse Voltage		$V_{RRM}$	40	30	20	V
RMS reverse voltage		$V_{RMS}$	28	21	14	V
Working Peak Reverse Voltage		$V_{DC}$	40	30	20	V
Peak Forward Surge Current, 8.3ms Single Half Sine-wave Superimposed On Rated Load(JEDEC method)		$I_{FSM}$	13			A
Maximum Instantaneous Forward Voltage	$I_F=20mA$	$V_F$	0.37			V
	$I_F=200mA$		0.60			
Power Dissipation		$P_D$	200			mW
Reverse current	1N5819WS, $V_R=30V$	$I_R$	5	-	-	uA
	1N5818WS, $V_R=20V$		-	5	-	
	1N5817WS, $V_R=10V$		-	-	5	
Thermal Resistance, Junction to Ambient Air		$R_{\theta JA}$	300			°C/W
Reverse voltage $I_R=100uA$	1N5819WS	$V_{(BR)R}$	40			V
	1N5818WS		30			
	1N5817WS		20			
Reverse recovery time $I_F=I_R=200mA, I_{rr}=0.1 \times I_R, R_L=100\Omega$		$T_{rr}$	10			nS
Forward Continuons Current		$I_{FM}$	350			mA
Total capacitance $V_R=0V, f=1MHZ$		$C_{tot}$	50			pF
Junction temperature		$T_j$	125			°C
Storage temperature		$T_{stg}$	-55 ~ +150			°C

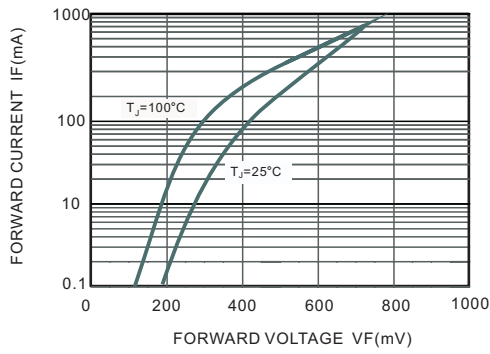
**Fig.1 Power Derating Curve**



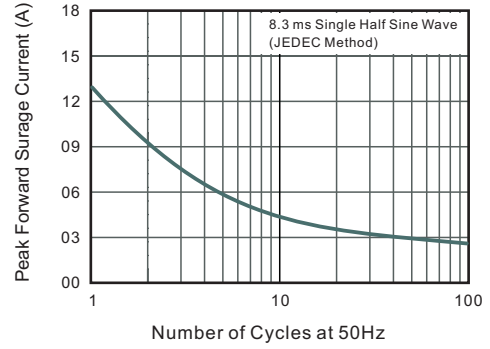
**Fig.2 Typical Reverse Characteristics**



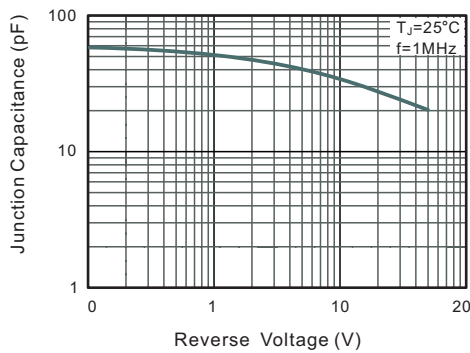
**Fig.3 Forward Characteristics**



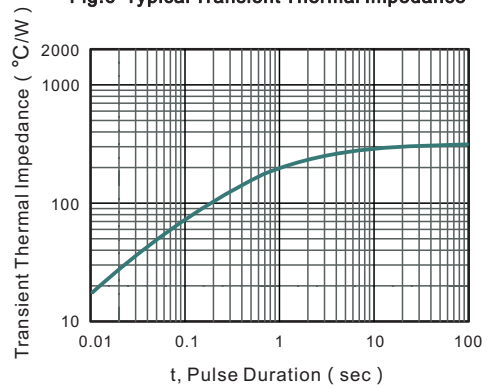
**Fig.4 Maximum Non-Repetitive Peak Forward Surge Current**



**Fig.5 Typical Junction Capacitance**

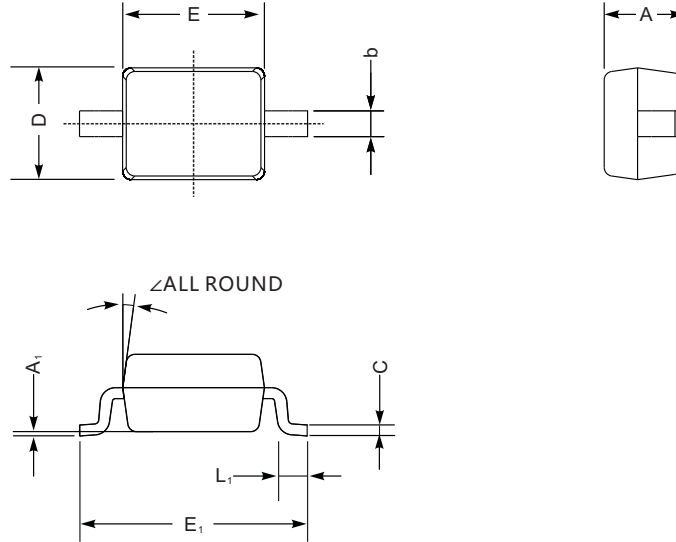


**Fig.6 Typical Transient Thermal Impedance**



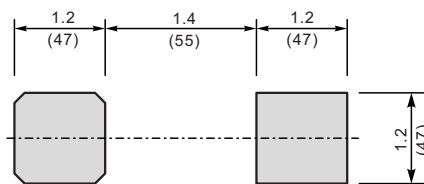
**Package Outline SOD-323**

Plastic surface mounted package; 2 leads



UNIT		A	C	D	E	E <sub>1</sub>	b	L <sub>1</sub>	A <sub>1</sub>	∠
mm	max	1.1	0.15	1.4	1.8	2.75	0.4	0.45	0.2	9°
	min	0.8	0.08	1.2	1.4	2.55	0.25	0.2	—	
mil	max	43	5.9	55	70	108	16	16	8	
	min	32	3.1	47	63	100	9.8	7.9	—	

**The recommended mounting pad size**



Unit:  $\frac{\text{mm}}{\text{(mil)}}$

**Summary of Packing Options**

Package	Packing Description	Packing Quantity	Industry Standard
SOD-323	Tape/Reel, 7" reel	3000	EIA-481-1