



钰地半导体
Tudi Semiconductor

Product Specification

TUDI-MCP6042

600 nA, Rail-to-Rail Input/Output Op Amps

网址 www.sztdbdt.com 🔍

用芯智造 · 卓越品质

**semiconductor device
manufacturer**

- Design
- research and development
- production
- and sales



Features

- Low Quiescent Current: 600 nA/amplifier (typical)
- Rail-to-Rail Input/Output
- Gain Bandwidth Product: 14 kHz (typical)
- Wide Supply Voltage Range: 1.4V to 6.0V
- Unity Gain Stable
- Available in Dual
- Available in MSOP8 and SOP8 Packages
- Temperature Ranges:
-40°C to +125°C

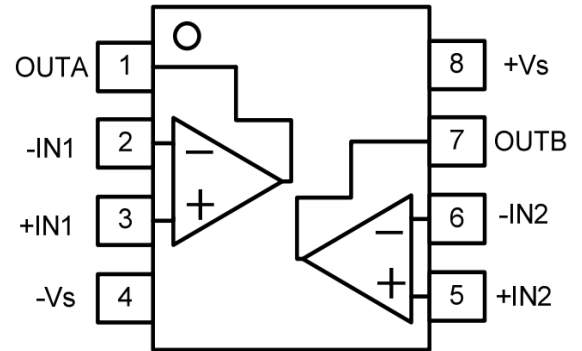

SOP8/MSOP8 Pin Diagram

Description

The MCP6042 operational amplifier operates with a dual power supply voltage as low as 1.4 V while drawing less than 1 μ A (max) static current per amplifier. These devices are also designed for rail-to-rail input and output operation. The combination of these features supports battery-powered and applications. The MCP6042 amplifier has a gain-bandwidth product of 14 kHz (typical) and is unity gain stable. These specifications make operational amplifiers ideal for low-frequency applications such as battery current monitoring and conditioning.

MCP6042 is a dual op amp.

The MCP6042 device is available in 8-pin MSOP and 8-pin SOP packages.

Applications

- Toll Booth Tags
- Wearable Products
- Temperature Measurement
- Battery Powered



Pin Functions

Name	Description	Note
+Vs	Positive power supply	A bypass capacitor of 0.1 μ F as close to the part as possible should be placed between power supply pins or between supply pins and ground.
-Vs	Negative power supply or ground	If it is not connected to ground, bypass it with a capacitor of 0.1 μ F as close to the part as possible.
-IN	Negative input	Inverting input of the amplifier. Voltage range of this pin can go from -Vs -0.3V to +Vs+0.3V.
+IN	Positive input	Non-inverting input of the amplifier. This pin has the same voltage range as -IN.
OUT	Output	The output voltage range extends to within millivolts of each supply rail.
NC	No connection	

Product Specification

Absolute Maximum Ratings (1)

Parameter	Rating	Units
Power Supply: +Vs to -Vs	6.0	V
Input Voltage	-Vs -0.5V to +Vs +0.5V	V
Input Current(2)	10	mA
Storage Temperature Range	-65 to 150	$^{\circ}$ C
Junction Temperature	150	$^{\circ}$ C
Operating Temperature Range	-40 to 125	$^{\circ}$ C
ESD Susceptibility, HBM	2000	V

(1) Stresses exceeding the absolute maximum ratings may damage the device. The device may not function or be operable above the recommended operating conditions and stressing the parts to these levels is not recommended. In addition, extended exposure to stresses above the recommended operating conditions may affect device reliability. The absolute maximum ratings are stress ratings only.

(2) Input terminals are diode-clamped to the power-supply rails. Input signals that can swing more than 0.5V beyond the supply rails should be current-limited to 10mA or less.



Recommended Operating Conditions

Parameter	Rating	Unit
DC Supply Voltage	1.4V ~ 5.5V	V
Input common-mode voltage range	-Vs ~ +Vs	V
Operating ambient temperature	-40 ~ 125	°C

Order information

Order Number	Package	Package Quantity	Marking On The park	Temperature
MCP6042T-I/SN-TUDI	SOP8	Tape,Reel,2500	MCP6042I/SN	-40°C to 85°C
MCP6042T-I/MS-TUDI	MSOP8	Tape,Reel,2500	6042I	
MCP6042-I/P-TUDI	DIP8	Tube,50,A box of 2000	MCP6042-I/P	
MCP6042T-E/SN-TUDI	SOP8	Tape,Reel,2500	MCP6042E/SN	-40°C to 125°C
MCP6042T-E/MS-TUDI	MSOP8	Tape,Reel,2500	6042E	
MCP6042-E/P-TUDI	DIP8	Tube,50,A box of 2000	MCP6042-E/P	



3.4 Electrical Characteristics

(+Vs=+5V,-Vs=0,VcM=Vs/2,TA=+25°C,RL=10kΩ to Vs/2,unless otherwise noted)

Parameter	Symbol	Conditions	Min	Typ	Max	Unit
Input Characteristics						
Input Offset Voltage	Vos			1	5	mV
Input Offset Voltage Drift	$\Delta V_{os}/\Delta T$	-40 to 125°C		2.5		$\mu V/^\circ C$
Input Bias Current	IB			1	10	pA
Input Offset Current	Ios			1	10	pA
Common-Mode Voltage Range	VcM	Vs =5.5V	-0.1		5.6	V
Common-Mode Rejection Ratio	CMRR	Vcm=0.1V to 4.9V		85		dB
Open-Loop Voltage Gain	AOL	Vo=0.2V to 4.8V		90		dB
Out Characteristics						
Output Voltage Swing from Rail		RL=50kΩ		10		mV
Short-Circuit Current	Isc			±20		mA
Power Supply						
Operating Voltage Range			1.4		5.5	V
Power Supply Rejection Ratio	PSRR	Vs=+1.8V to+5.5V		85		dB
Quiescent Current/Amplifier	Io			500		nA
Dynamic Performance						
Gain Bandwidth Product	GBWP	G=+1		24		kHz
Slew Rate	SR	G=+1,2V Output Step		4.3		V/ms
Noise Performance						
Voltage Noise Density	en	f=1kHz		170		nV/√Hz



Application Notes

Driving Capacitive Loads

Driving large capacitive loads can cause stability problems for voltage feedback op amps. As the load capacitance increases, the feedback loop's phase margin decreases, and the closed loop bandwidth is reduced. This produces gain peaking in the frequency response, with overshoot and ringing in the step response. A unity gain buffer ($G = +1$) is the most sensitive to capacitive loads, but all gains show the same general behavior.

When driving large capacitive loads with these op amps (e.g., > 100 pF when $G = +1$), a small series resistor at the output (R_{iso} in Figure 1) improves the feedback loop's phase margin (stability) by making the output load resistive at higher frequencies. It does not, however, improve the bandwidth. To select R_{iso} , check the frequency response peaking (or step response overshoot) on the bench. If the response is reasonable, you do not need R_{iso} . Otherwise, start R_{iso} at $1\text{ k}\Omega$ and modify its value until the response is reasonable.

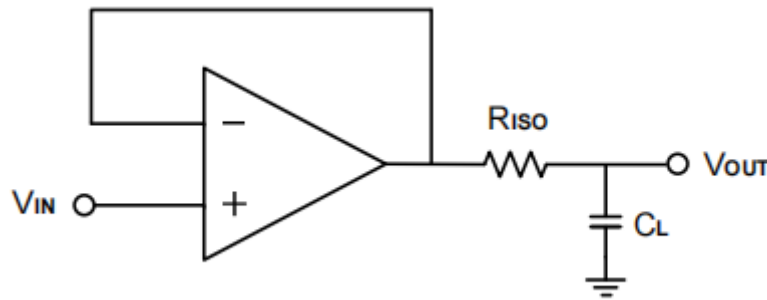

An improvement circuit is shown in Figure 2. It provides DC accuracy as well as AC stability. R_F provides the DC accuracy by connecting the inverting signal with the output, C_F and R_{iso} serve to counteract the loss of phase margin by feeding the high frequency component of the output signal back to the amplifier's inverting input, thereby preserving phase margin in the overall feedback loop.

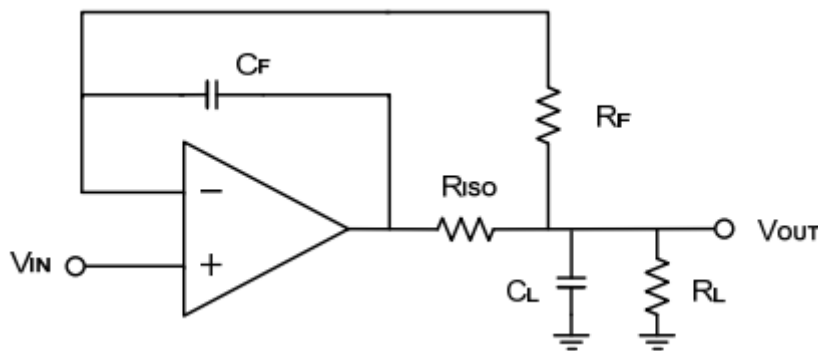

Figure 2. Indirectly Driving Heavy Capacitive Load with DC Accuracy



For noninverting configuration, there are two others ways to increase the phase margin: (a) by increasing the amplifier ' s gain or (b) by placing a capacitor in parallel with the feedback resistor to counteract the parasitic capacitance associated with inverting node, as shown in Figure 3.

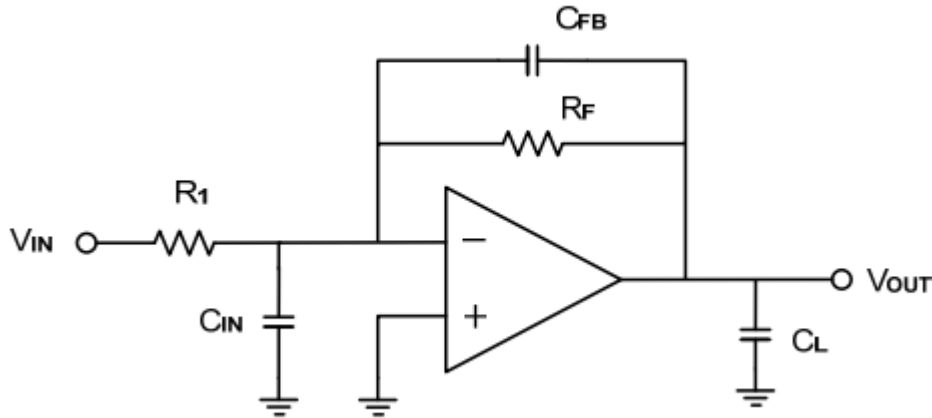

Figure 3. Adding a Feedback Capacitor in the Noninverting Configuration

Power-Supply Bypassing and Layout

The MCP6042 operates from a dual +1.4V to +5.5V supply. A 0.1μF ceramic capacitor should be placed close to the +Vs pin to bypass the power supply +Vs. 2.2μF tantalum capacitor can be added for better performance.

The length of the current path is directly proportional to the magnitude of parasitic inductances and thus the high frequency impedance of the path. High speed currents in an inductive ground return create an unwanted voltage noise. Broad ground plane areas will reduce the parasitic inductance.

Typical Application Circuits

Differential Amplifier

The circuit shown in Figure 4 performs the differential function. If the resistors ratios are equal ($R4 / R3 = R2 / R1$), then $V_{ou} = (V_{Ip} - V_{In}) \times R2 / R1 + V_{REF}$.

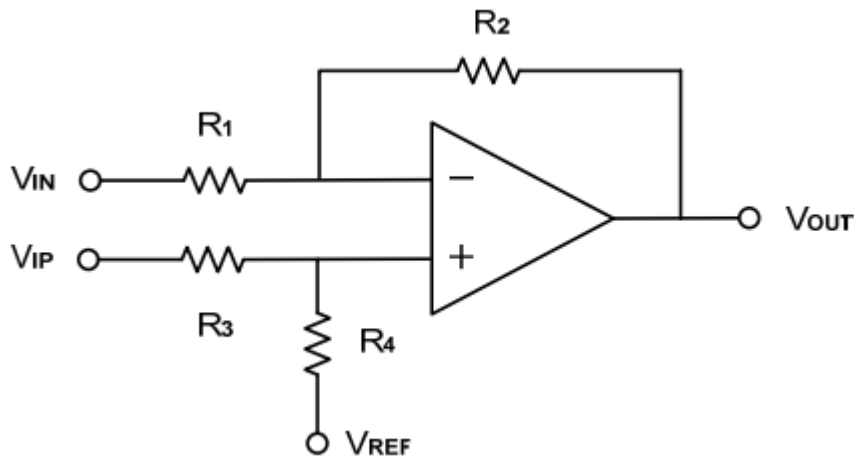

Figure 4. Differential Amplifier

Low Pass Active Filter

When receiving low-level signals, limiting the bandwidth of the incoming signals into the system is often required. The simplest way to establish this limited bandwidth is to place an RC filter at the noninverting terminal of the amplifier. If even more attenuation is needed, a multiple pole filter is required. The Sallen-Key filter can be used for this task, as Figure 5. For best results the amplifiers should have a bandwidth that is 8 to 10 times the filter frequency bandwidth. Failure to follow this guideline can result in reduction of phase margin. The large values of feedback resistors can couple with parasitic capacitance and cause undesired effects such as ringing or oscillation in high-speed amplifiers. Keep resistors value as low as possible and consistent with output loading consideration.

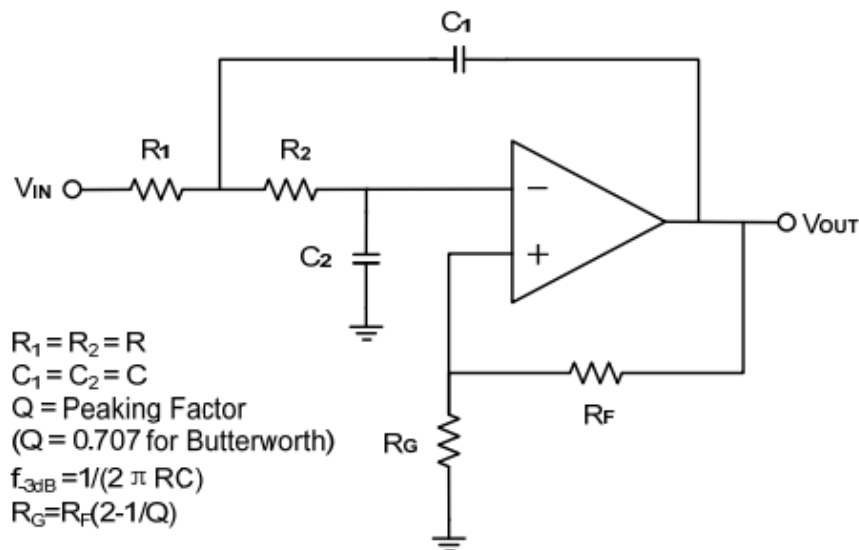

Figure 5. Two-Pole Low-Pass Sallen-Key Active Filter



Package SOP8



Symbol	Dimensions In Millimeters		Dimensions In Inches	
	Min	Max	Min	Max
A	1.350	1.750	0.053	0.069
A1	0.100	0.250	0.004	0.010
A2	1.350	1.550	0.053	0.061
B	0.330	0.510	0.013	0.020
C	0.190	0.250	0.007	0.010
D	4.780	5.000	0.188	0.197
E	3.800	4.000	0.150	0.157
E1	5.800	6.300	0.228	0.248
e	1.270TYP		0.050TYP	
L	0.400	1.270	0.016	0.050
θ	0°	8°	0°	8°





Package MSOP8

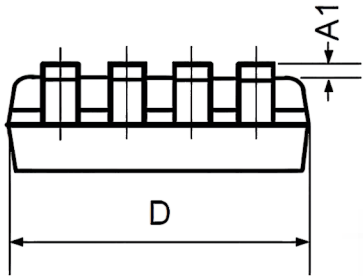
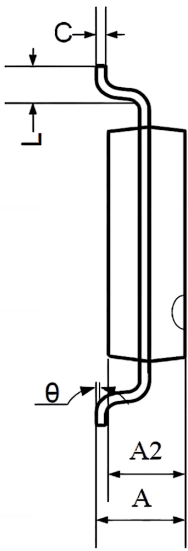
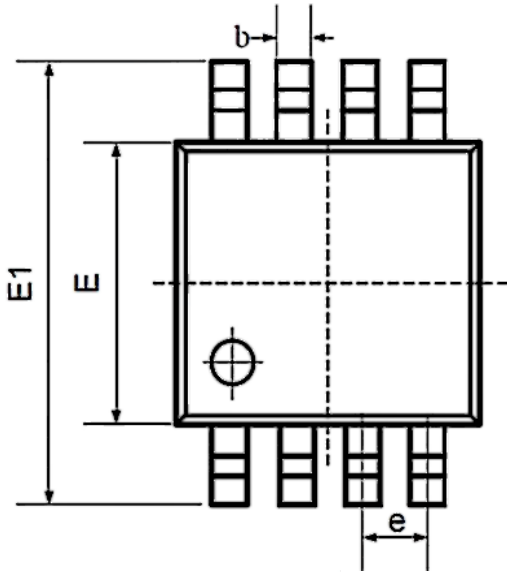

Symbol	Dimensions In Millimeters		Dimensions In Inches	
	Min	Max	Min	Max
A	0.800	1.200	0.031	0.047
A1	0.000	0.200	0.000	0.008
A2	0.760	0.970	0.030	0.038
b	0.30 TYP		0.012 TYP	
C	0.15 TYP		0.006 TYP	
D	2.900	3.100	0.114	0.122
e	0.65 TYP		0.026 TYP	
E	2.900	3.100	0.114	0.122
E1	4.700	5.100	0.185	0.201
L	0.410	0.650	0.016	0.026
θ	0°	6°	0°	6°



Package DIP8

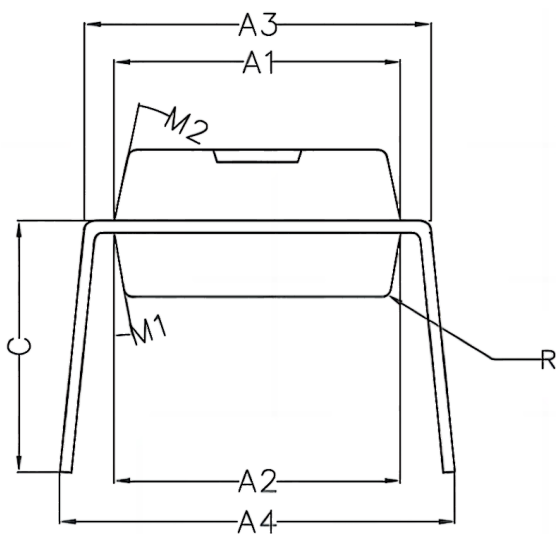
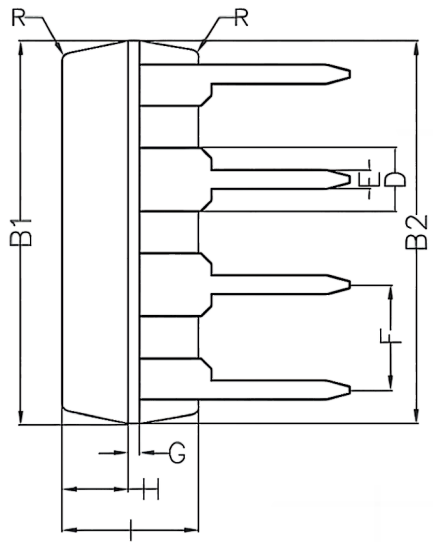
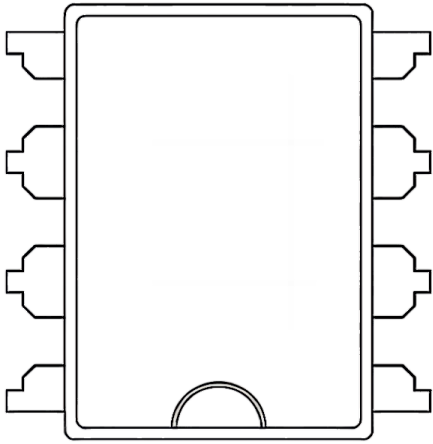

Symbol	Min	Non	Max
A1	6.28	6.33	6.38
A2	6.33	6.38	6.43
A3	7.52	7.62	7.72
A4	7.80	8.40	9.00
B1	9.15	9.20	9.25
B2	9.20	9.25	9.30
C		5.57	
D		1.52	
E	0.43	0.45	0.47
F		2.54	
G		0.25	
H	1.54	1.59	1.64
I	3.22	3.27	3.32
R		0.20	
M1	9°	10°	11°
M2	11°	12°	13°



Important statement:

- TUDI Semiconductor reserves the right to modify the product manual without prior notice! Before placing an order, customers need to confirm whether the obtained information is the latest version and verify the completeness of the relevant information.
- Any semi-guide product is subject to failure or malfunction under specified conditions. It is the buyer's responsibility to comply with safety standards when using TUDI Semiconductor products for system design and whole machine manufacturing. And take the appropriate safety measures to avoid the potential in the risk of loss of personal injury or loss of property situation!
- TUDI Semiconductor products have not been licensed for life support, military, and aerospace applications, and therefore TUDI Semiconductor is not responsible for any consequences arising from the use of this product in these areas.
- If any or all TUDI Semiconductor products (including technical data, services) described or contained in this document are subject to any applicable local export control laws and regulations, they may not be exported without an export license from the relevant authorities in accordance with such laws.
- The specifications of any and all TUDI Semiconductor products described or contained in this document specify the performance, characteristics, and functionality of said products in their standalone state, but do not guarantee the performance, characteristics, and functionality of said products installed in Customer's products or equipment. In order to verify symptoms and conditions that cannot be evaluated in a standalone device, the Customer should ultimately evaluate and test the device installed in the Customer's product device.
- TUDI Semiconductor documentation is only allowed to be copied without any alteration of the content and with the relevant authorization. TUDI Semiconductor assumes no responsibility or liability for altered documents.
- TUDI Semiconductor is committed to becoming the preferred semiconductor brand for customers, and TUDI Semiconductor will strive to provide customers with better performance and better quality products.