

LM2902

DATASHEET

Specification Revision History:

Version	Date	Description
V1.0	2019/08	New
V1.1	2021/05	Modify Ordering Information
V1.2	2025/02	Modify Ordering Information
V1.3	2025/03	Add application precautions and overall typesetting.

Description

The LM2902 consists of four independent, high gain internally frequency compensated operational amplifiers which were designed specifically to operate from a single power supply over a wide voltage range.

Operation from split power supplies is also possible so long as the difference between the two supplies is 3 Volts to 30 volts.

Application areas include transducer amplifier, DC gain blocks and all the conventional OP amp circuits which now can be easily implemented in single power supply system.

Features

- ※ Internally frequency compensated for unity gain
- ※ Large DC voltage gain: 100dB
- ※ Wide operating supply range ($V_{CC}=3V\sim 30V$)
- ※ Input common-mode voltage includes ground
- ※ Large output voltage swing: From 0V to $V_{CC}-2.0V$
- ※ Power drain suitable for battery operation

The appearance of the product

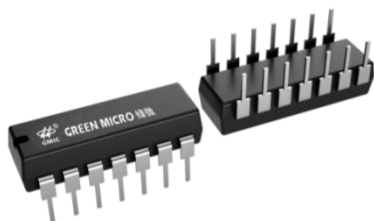

DIP-14

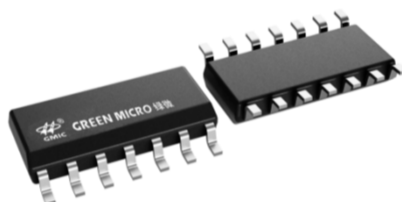

SOP-14

Ordering Information

Product Model	Package Type	Packing	Packing Qty
LM2902N(GMIC)	DIP-14	TUBE	1000PCS/BOX
LM2902DR(GMIC)	SOP-14	REEL	2500PCS/REEL
LM2902	DIP-14	TUBE	1000PCS/BOX
LM2902	SOP-14	REEL	2500PCS/REEL

Pin Configuration

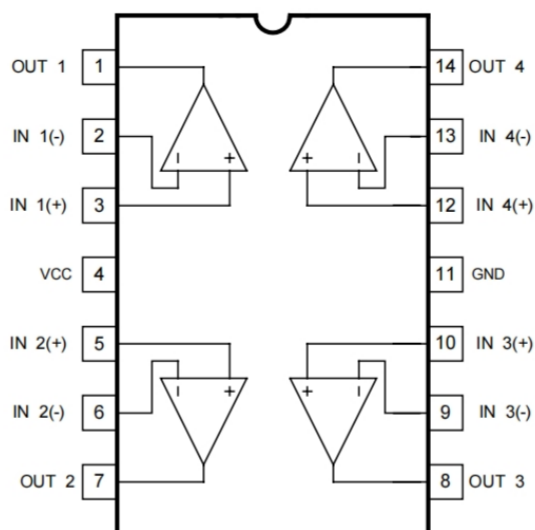

Block Diagram

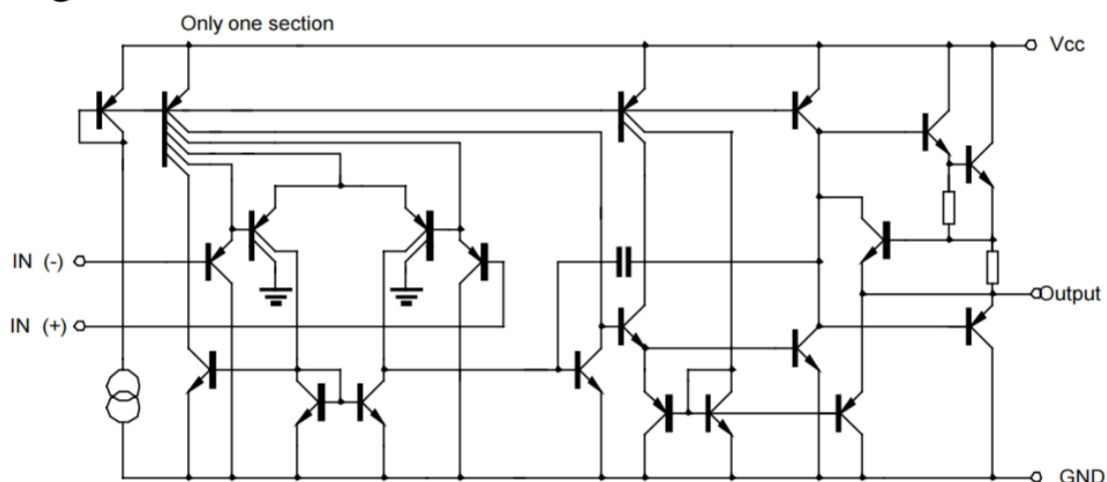

Absolute Maximum Ratings (Ta=25°C)

Characteristic	Symbol	Value	Unit
Supply Voltage	V_{CC}	± 15	V
Differential input voltage	$V_{i(diff)}$	30	V
Input Voltage	V_I	-0.3~30V	V
Power Dissipation	P_d	570	mW
Operating Temperature	T_{opr}	0 to+70	C
Storage Temperature	T_{stg}	-65to 150	°C

Electrical Characteristics($T_a=25^{\circ}\text{C}$)

 ($V_{CC}=5.0\text{V}$, All voltage referenced to GND unless otherwise specified)

Characteristic	Symbol	Test Condition	Min	Typ.	Max	Unit
Input offset voltage	V_{IO}	$V_{CM}=0$ to $V_{CC}-1.5$ $V_o(p)=1.4\text{V}, R_s=0$		2.0	7.0	mV
Input offset current	I_{IO}			3.0	50	nA
Input Bias current	I_b			40	250	nA
Input Common-mode voltage range	$V_{I(R)}$	$V_{CC}=30\text{V}$	0	$V_{CC}-2.0$		V
Supply Current	I_{CC}	$R_L=\infty, V_{CC}=30\text{V}$		1.0	4	mA
		$V_{CC}=5\text{V}$		0.7	2	mA
Large signal Voltage Gain	G_V	$V_{CC}=15\text{V}, R_L>2\text{k}\Omega$ $V_o(p)=1\text{V}$ to 11V	25	100		V/mV
Output voltage Swing	$V_{(OH)}$	$V_{CC}=30\text{V}, R_L=2\text{k}\Omega$	26			V
		$V_{CC}=30\text{V}, R_L=10\text{k}\Omega$	26	28		V
	$V_{(OL)}$	$V_{CC}=5, R_L>10\text{k}\Omega$		5	20	mV
Common-mode rejection Ratio	CMRR		65	75		dB
Power supply rejection Ratio	PSRR		65	100		dB
Channel Separation	CS	$f=1\text{kHz}$ to 20kHz		5	20	mV
Short circuit to GND	I_{sc}			40	60	mA
Output current	I_{source}	$V_I(+)=1\text{V}, V_I(-)=0$ $V_{CC}=15\text{V}, V_o(p)=2\text{V}$	20	40		mA
	I_{sink}	$V_I(+)=0\text{V}, V_I(-)=1\text{V}$ $V_{CC}=15\text{V}, V_o(p)=2\text{V}$	10	13		mA
		$V_I(+)=1\text{V}, V_I(-)=0$ $V_{CC}=15\text{V}, V_o(p)=200\text{mV}$	12	45		μA
Differential input voltage	$V_{I(diff)}$				V_{CC}	V

Typical Characteristics Performance

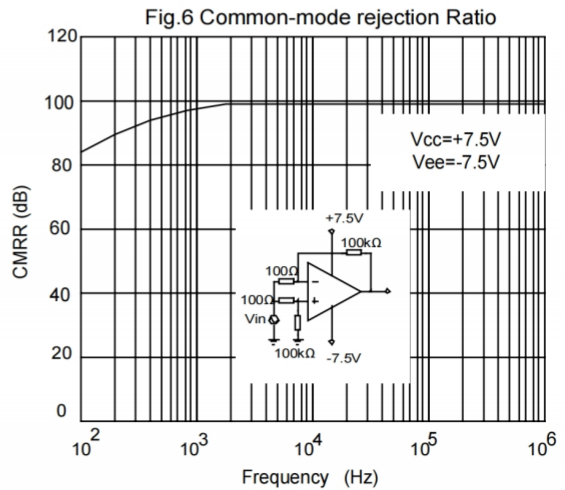
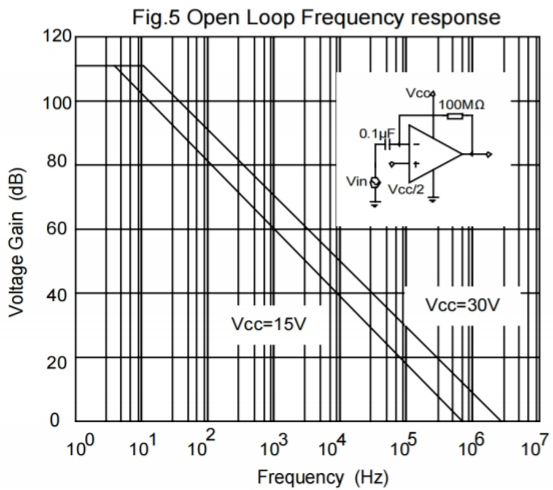
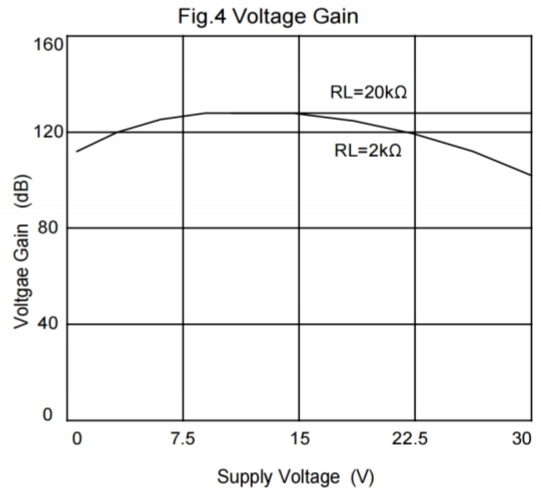
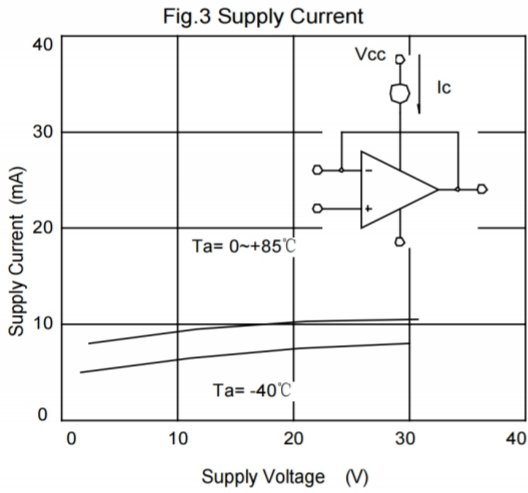
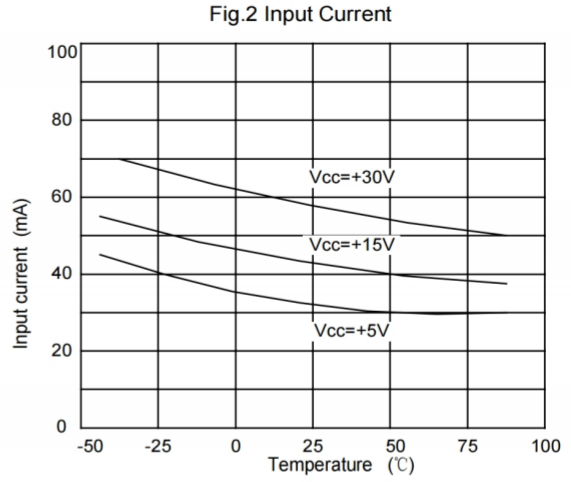
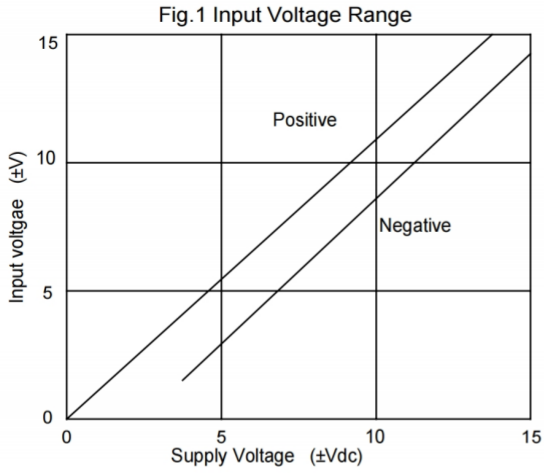

Fig.7

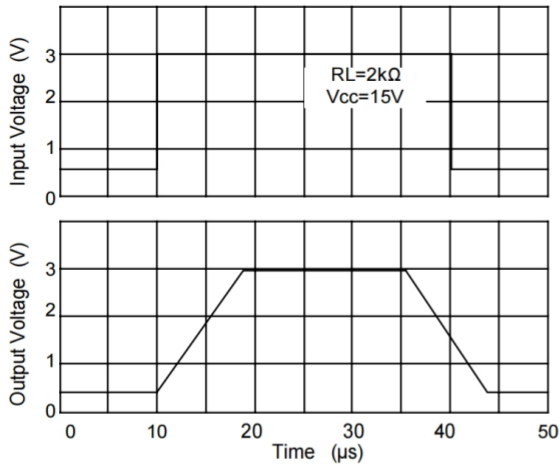

Fig.8 voltage Follower pulse response (small signal)

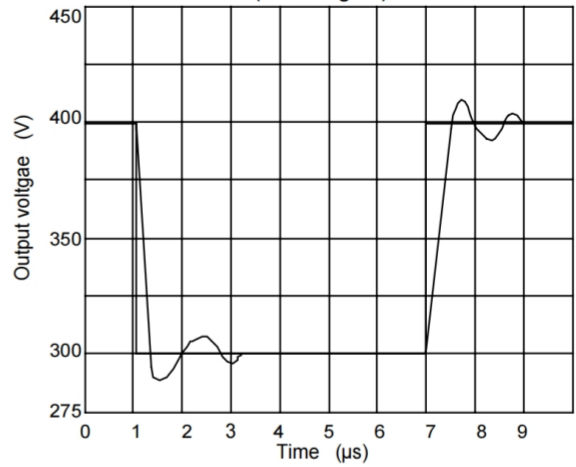

Fig.9 Large signal Frequency Response

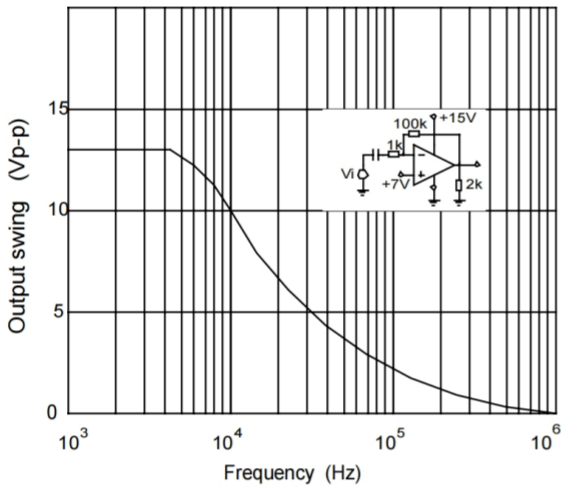

Fig.10 Output Characteristics current sourcing

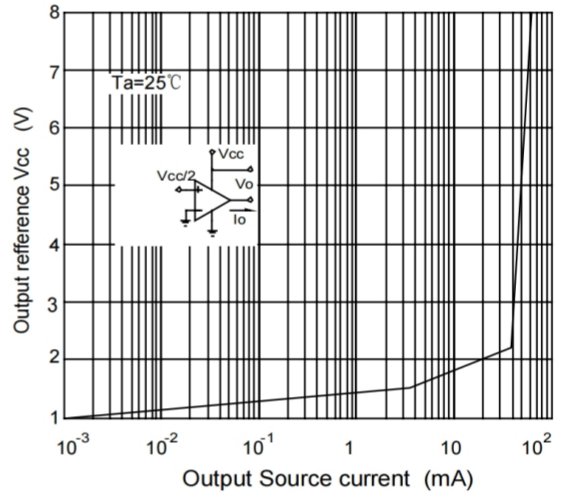

Fig.11 Output Characteristics Current sinking

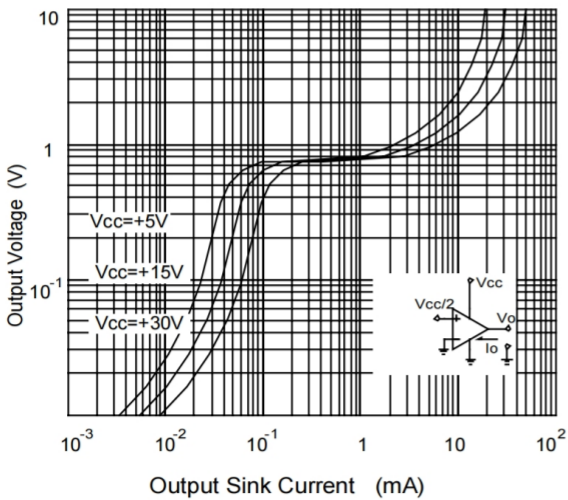
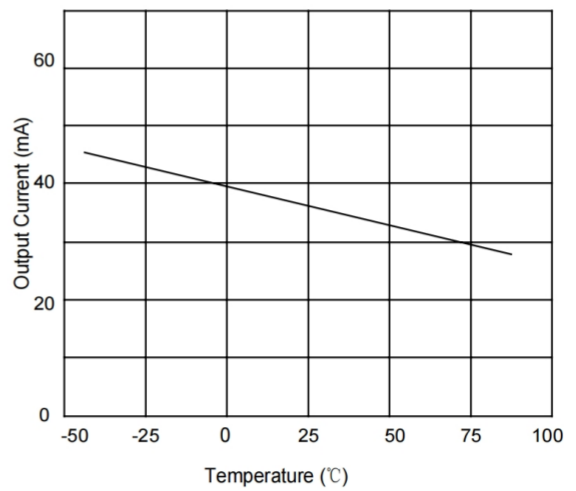
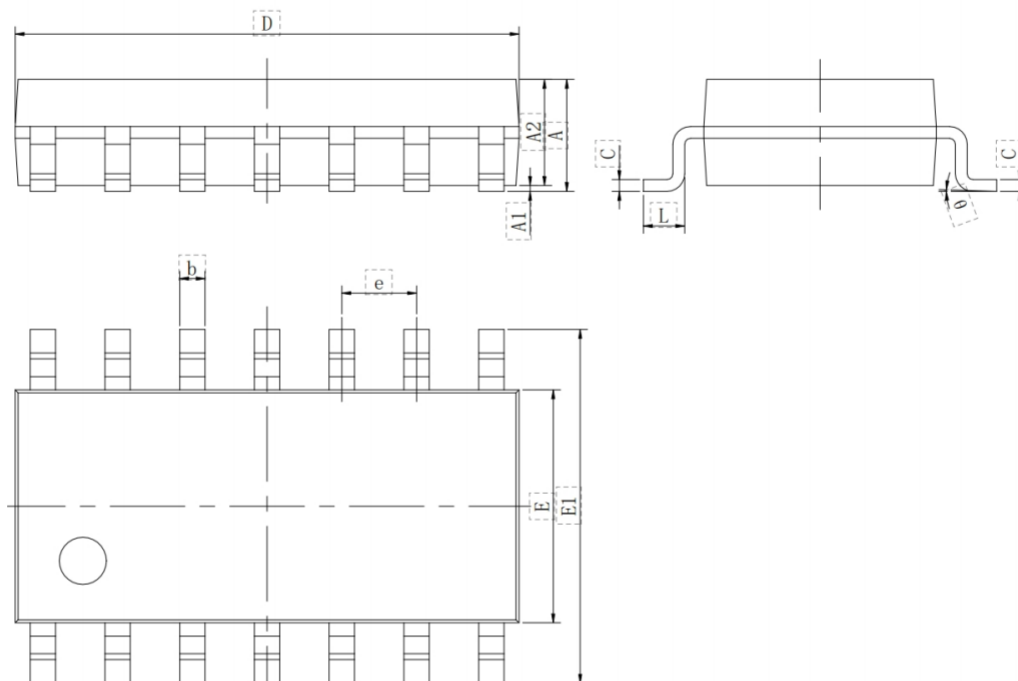

Fig.12 Current Limiting



Outline Dimensions

SOP-14



Symbol	Dimensions In Millimeters		Dimensions In Inches	
	Min	Max	Min	Max
A	1.350	1.750	0.053	0.069
A1	0.100	0.250	0.004	0.010
A2	1.350	1.550	0.053	0.061
b	0.330	0.510	0.013	0.020
c	0.170	0.250	0.007	0.010
D	8.360	8.760	0.329	0.345
E	3.800	4.000	0.150	0.157
E1	5.800	6.200	0.228	0.244
e	1.270(BSC)		0.050(BSC)	
L	0.400	1.270	0.016	0.050
θ	0°	8°	0°	8°

DIP-14

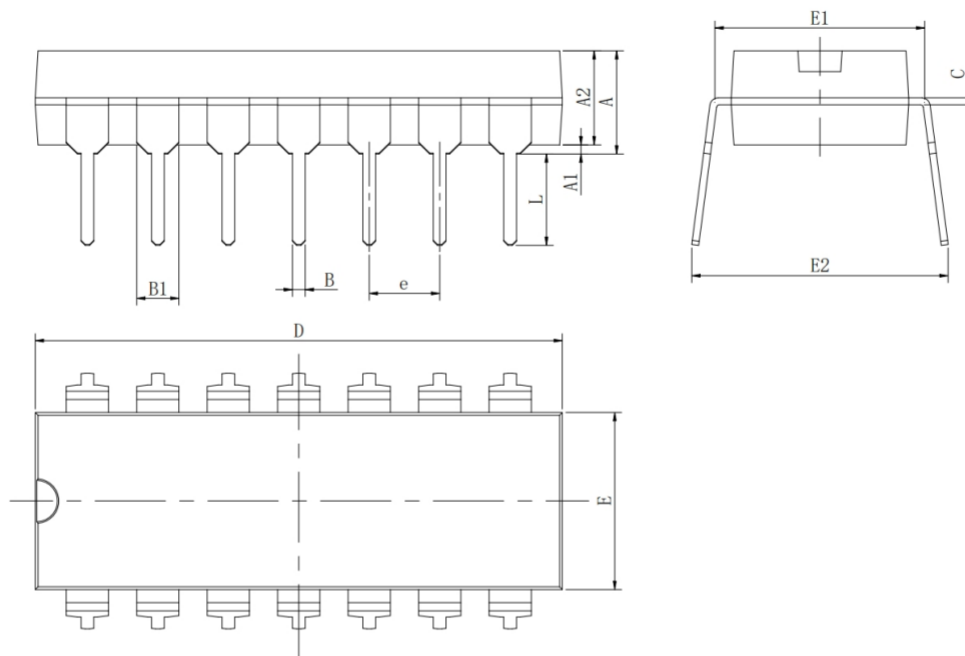

Symbol	Dimensions In Millimeters		Dimensions In Inches	
	Min	Max	Min	Max
A	3.710	4.310	0.146	0.170
A1	0.510		0.020	
A2	3.200	3.600	0.126	0.142
B	0.380	0.570	0.015	0.022
B1	1.524(BSC)		0.060(BSC)	
C	0.204	0.360	0.008	0.014
D	18.800	19.200	0.740	0.756
E	6.200	6.600	0.244	0.260
E1	7.320	7.920	0.288	0.312
e	2.540(BSC)		0.100(BSC)	
L	3.000	3.600	0.118	0.142
E2	8.400	9.000	0.331	0.354

Important Notice

- Green Micro chip reserves the right to change products and documents without notice. Customers should obtain and verify the completeness of the latest technical information before placing orders. Meanwhile, Green Micro chip shall not assume any responsibility or obligation for non-officially revised documents.
- Any parameters in the entire product specification are for reference only, and actual application testing shall prevail. When customers use the products for system design, they must comply with safety regulations and independently assume the following responsibilities: selecting suitable Green Micro chip products according to application requirements; completing design verification and full-link testing of the application; and ensuring that the application complies with safety regulations or other requirements of the target market. Customers shall bear all personal or property losses caused by design defects or illegal operations, which shall have no relation to Green Micro chip.
- Green Micro chip products are prohibited from being used in scenarios such as life support, military equipment, and key aerospace applications. All accidents and legal liabilities arising from out-of-scope use shall be borne by the user, and Green Micro chip shall not be held responsible.
- All technical resources of Green Micro chip (including data sheets and reference designs) are provided "as is", without guarantee of no defects or universality, and without any express or implied warranties. The documents are only authorized for product development and research described in this document. Unauthorized use of intellectual property, public reproduction, and reverse engineering are strictly prohibited. All claims and losses caused by illegal use shall be borne by the user, and Green Micro chip shall not be liable.